

DESIGN DESIGNATION

A.A.D.T. - 2014 = 10,722
 A.A.D.T. - 2034 = 14,474
 T = 10%
 V = 35 M.P.H.

FUNCTIONAL CLASSIFICATION- URBAN MINOR ARTERIAL

NO RIGHT OF WAY IS TO BE ACQUIRED FOR THIS PROJECT

MISSOURI HIGHWAYS AND TRANSPORTATION COMMISSION PLANS FOR PROPOSED STATE HIGHWAY JACKSON COUNTY

INDEX OF SHEETS

DESCRIPTION	SHEET NUMBER
TITLE SHEET -----	1
TYPICAL SECTIONS (TS) (2 SHEETS)--	2
QUANTITIES (QU) (3 SHEETS)-----	3
PLAN (PP, EC, PM AND SN)-----	4
SPECIAL SHEETS (SS)-----	5-11
TRAFFIC CONTROL SHEETS (TC)-----	12-21
SIGNALS (SG)-----	22-28
SIGNING (SN)-----	29
BRIDGE DRAWINGS (B)	
A08073-----	1-49

"THIS MEDIA SHOULD NOT BE CONSIDERED A CERTIFIED DOCUMENT."

DATE PREPARED
2/6/2014

ROUTE STATE
I-670 MO

DISTRICT SHEET NO.
KC 1

COUNTY
JACKSON

JOB NO.
J412023

CONTRACT ID.

PROJECT NO.

BRIDGE NO.
A08073

DATE	DESCRIPTION

MISSOURI HIGHWAYS AND TRANSPORTATION COMMISSION

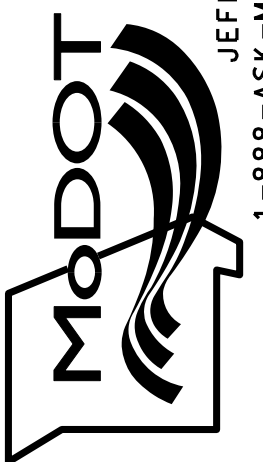

105 WEST CAPITOL
 JEFFERSON CITY, MO 65102
 1-888-ASK-MODOT (1-888-273-6636)

IF A SEAL IS PRESENT ON THIS SHEET IT HAS BEEN ELECTRONICALLY SEALED AND DATED.

CONVENTIONAL SYMBOLS
(USED IN PLANS)

	EXISTING	NEW
BUILDINGS AND STRUCTURES		
GUARD RAIL		
CONCRETE RIGHT-OF-WAY MARKER		
STEEL RIGHT-OF-WAY MARKER		
LOCATION SURVEY MARKER		
UTILITIES		
FIBER OPTICS		
OVERHEAD TELEPHONE		
UNDERGROUND TELEPHONE		
OVERHEAD POWER		
UNDERGROUND POWER		
GAS		
WATER		
MANHOLE		
FIRE HYDRANT		
WATER VALVE		
WATER METER		
DROP INLET		
DITCH BLOCK		
GROUND MOUNTED SIGN		
LIGHT POLE		
H-FRAME POWER POLE		
TELEPHONE PEDESTAL		
FENCE		
CHAIN LINK		
WOVEN WIRE		
GATE POST		
BENCHMARK		

NOTE: DASHED OR OPEN SYMBOLS INDICATE EXISTING FEATURES

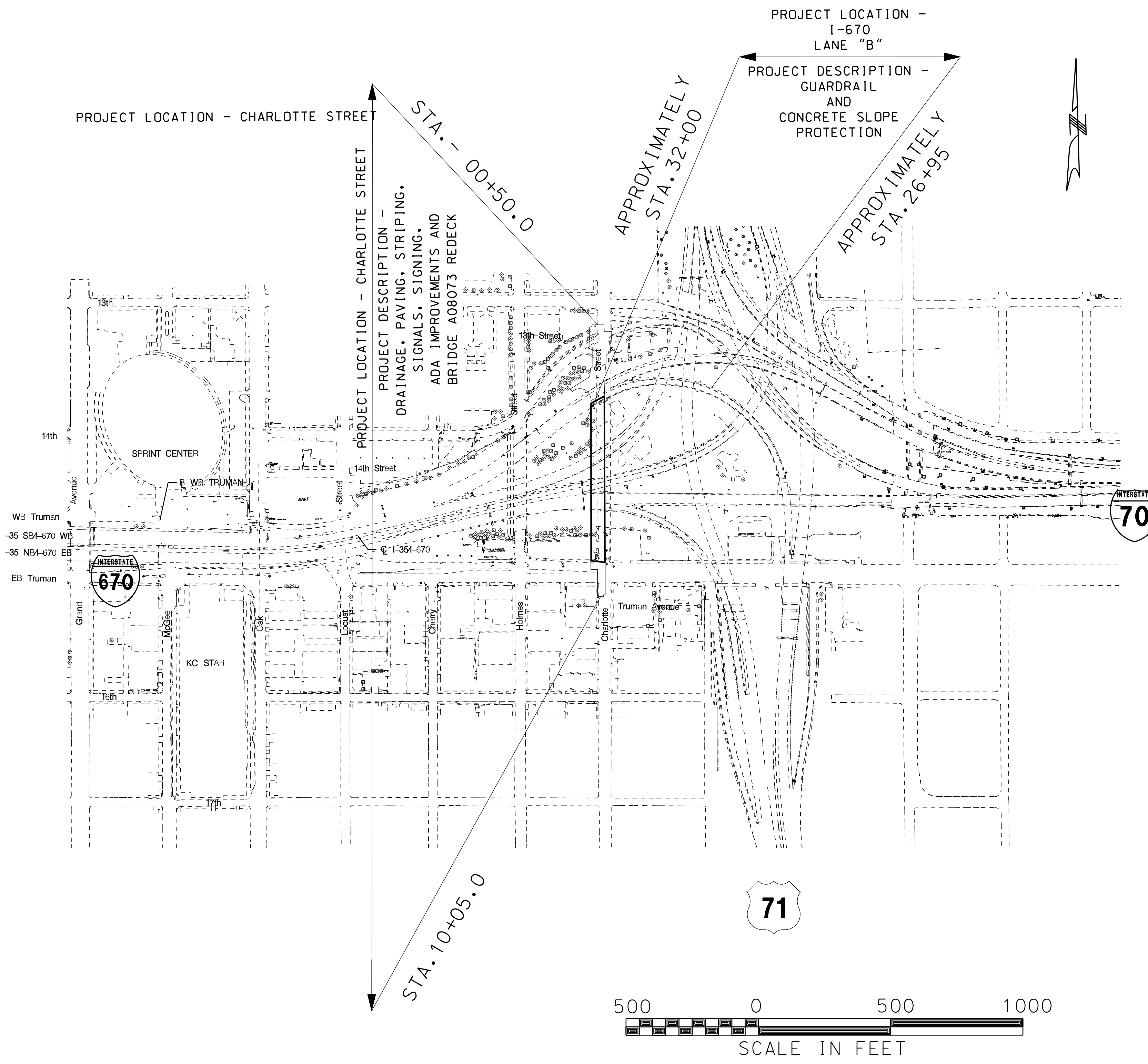

LENGTH OF PROJECT

BEGINNING OF PROJECT	STA. - 00 + 50.0
END OF PROJECT	STA. 10 + 05.0
APPARENT LENGTH	1055.0 FEET
EQUATIONS AND EXCEPTIONS:	NONE
TOTAL CORRECTIONS	0.00 FEET
NET LENGTH OF PROJECT	1055.0 FEET
STATE LENGTH	0.20 MILES

"THIS MEDIA SHOULD NOT BE CONSIDERED A CERTIFIED DOCUMENT."

DATE PREPARED
1/7/2014

ROUTE I-670 STATE MO
DISTRICT KC SHEET NO. 2
COUNTY JACKSON
JOB NO. J412023
CONTRACT ID.

PROJECT NO.

BRIDGE NO. A08073

DESCRIPTION	DATE

MISSOURI HIGHWAYS AND TRANSPORTATION COMMISSION

MoDOT

105 WEST CAPITOL
JEFFERSON CITY, MO 65102
1-888-ASK-MODOT (1-888-273-6636)

IF A SEAL IS PRESENT ON THIS SHEET IT HAS BEEN ELECTRONICALLY SEALED AND DATED.

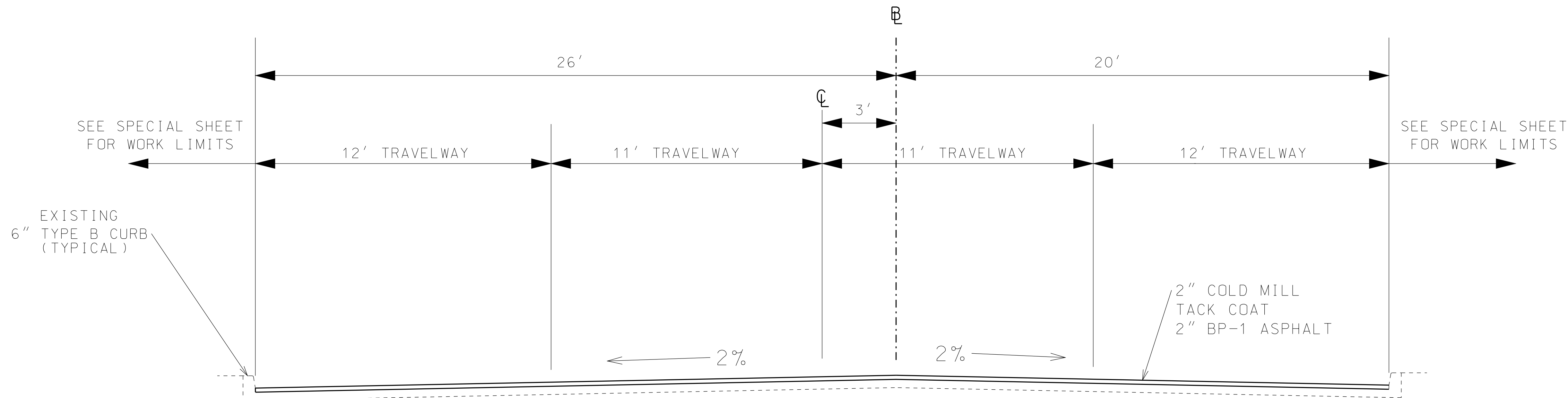

STATION - 00+50.0 TO 0+93.5

- (1) SEE SPECIAL SHEETS FOR WORK LIMITS
- (2) SEE SPECIAL SHEETS FOR SLOPES

FOR INFORMATION ONLY

ESTIMATE FACTOR (TONS/CUBIC YARD)	1.971
EST. FACTOR (GAL/SQ YD)	0.08

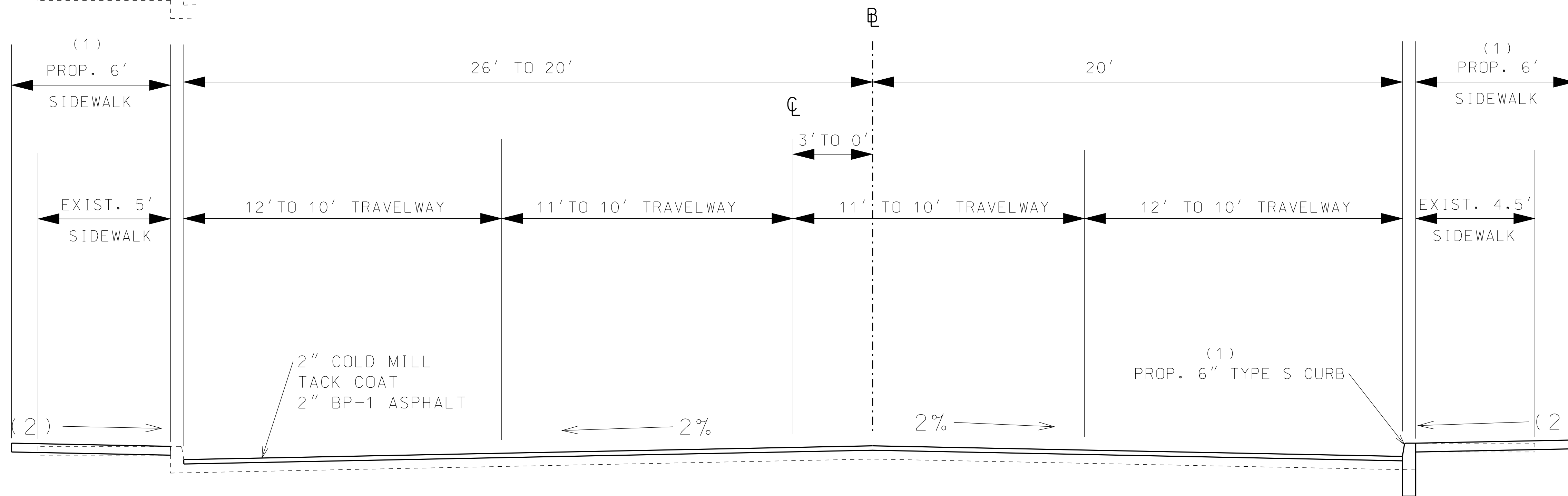
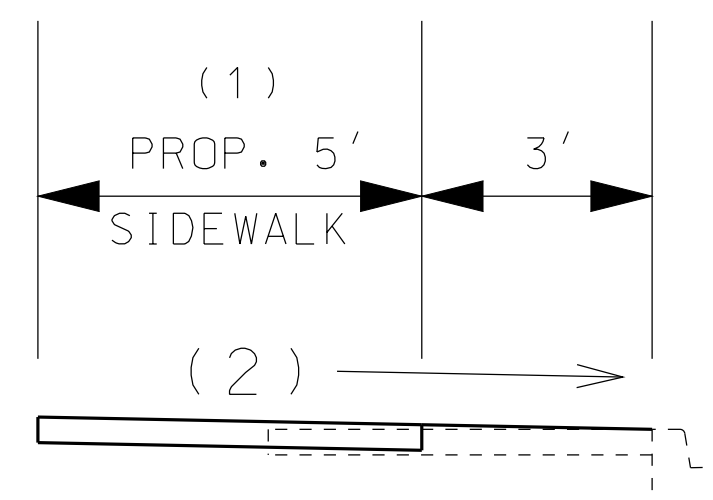

STATION 0+93.5 TO * 2+37.4

TYPICAL SECTION SHEET
SHEET 1 OF 2

* BEGINNING OF EXISTING BRIDGE APPROACH SLAB

"THIS MEDIA SHOULD NOT BE CONSIDERED A CERTIFIED DOCUMENT."

DATE PREPARED
1/7/2014

ROUTE STATE
I-670 MO

DISTRICT SHEET NO.
KC 2

COUNTY
JACKSON

JOB NO.
J412023

CONTRACT ID.

PROJECT NO.

BRIDGE NO.
A08073

DESCRIPTION	DATE

DATE

MISSOURI HIGHWAYS AND TRANSPORTATION COMMISSION

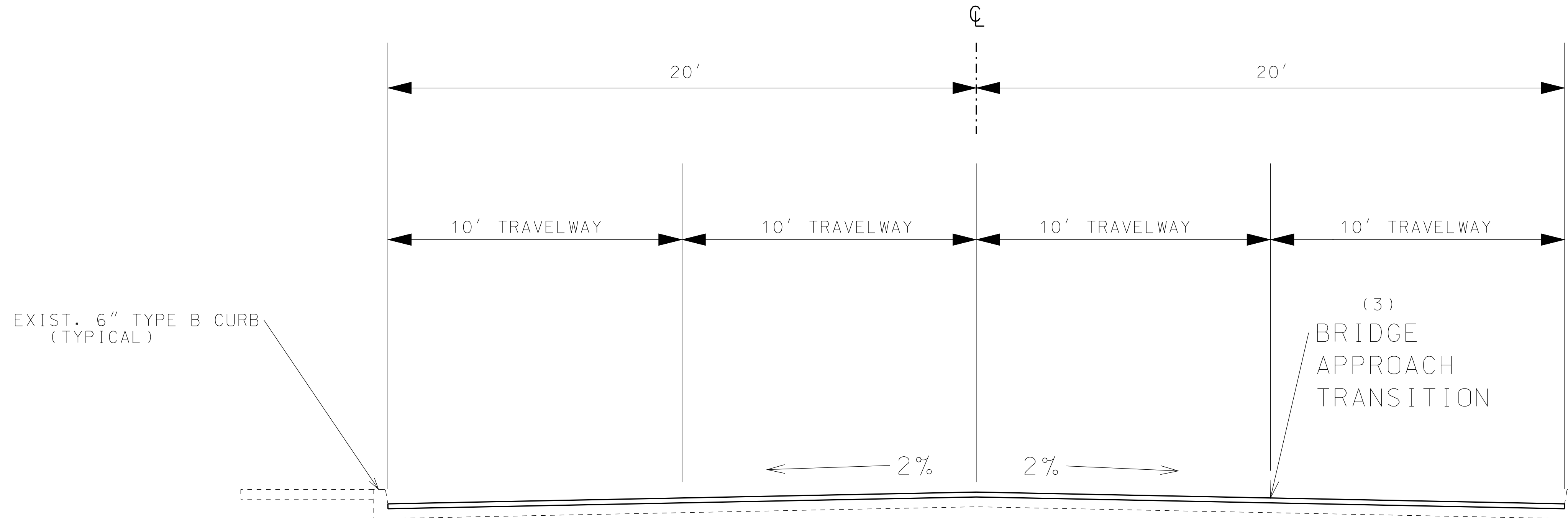
105 WEST CAPITOL
JEFFERSON CITY, MO 65102
1-888-ASK-MODOT (1-888-273-6636)



- (2) SEE SPECIAL SHEETS FOR SLOPES
- (3) SEE SPECIAL SHEET FOR PAVEMENT TRANSITION AT BRIDGE ENDS

FOR INFORMATION ONLY

ESTIMATE FACTOR (TONS/CUBIC YARD)
1.971
EST. FACTOR (GAL/SQ YD)
0.08

** BASELINE STATION AT SKEWED BRIDGE FILL FACE

STATION 2+37.4 TO ** 2+68.9
STATION ** 8+49.8 TO 8+71.5

- (5) END AT NEWER SIDEWALK (APPROX. STATION 8+95)
- (6) EXCEPT OUT RIGHT TWO LANES FROM APPROX. STATION 8+60 TO 10+05 (EXISTING "WHITE TOPPED" AREA)

(4) END AT NEWER SIDEWALK (APPROX. STATION 9+88)

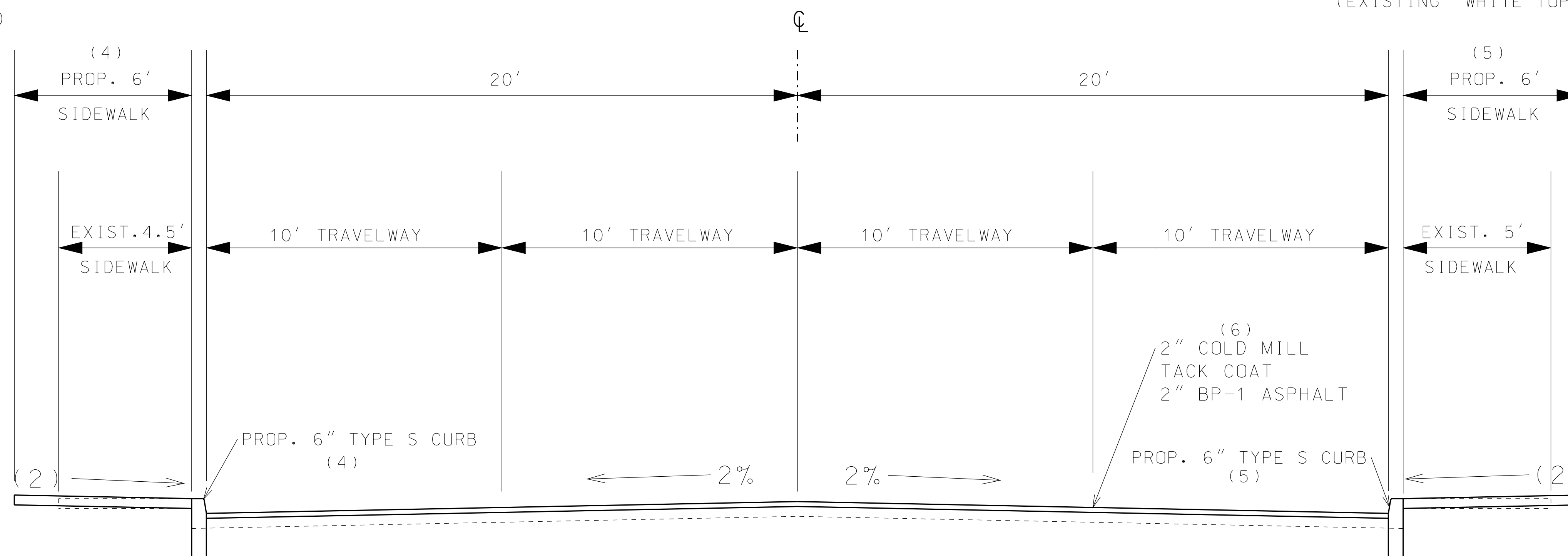

* END OF EXISTING BRIDGE APPROACH SLAB

STATION * 8+71.51 TO 10+05

TYPICAL SECTION SHEET
SHEET 2 OF 2

IF A SEAL IS PRESENT ON THIS SHEET IT HAS BEEN ELECTRONICALLY SEALED AND DATED.

MISSOURI HIGHWAYS AND TRANSPORTATION COMMISSION

SUMMARY OF QUANTITIES

THIS MEDIA SHOULD NOT BE CONSIDERED A CERTIFIED DOCUMENT.

DATE PREPARED
2/6/2014

ROUTE I-670	STATE MO
DISTRICT KC	SHEET NO. 3

COUNTY
JACKSON
JOB NO.
J412023
CONTRACT ID.

PROJECT NO.

BRIDGE NO.
A08073

MOBILIZATION	
PAY TOTAL:	ONE LUMP SUM

CONTRACTOR SURVEYING & STAKING	
PAY TOTAL:	ONE LUMP SUM

LOCATION	REMOVAL OF IMPROVEMENTS								
	* SIDEWALK OR ISLAND (SQ. YARDS)	* CURB (LINEAR FEET)	DRAINAGE GRATES (EACH)	GUARDRAIL (LINEAR FEET)	PARKING LOT RAILING (LINEAR FEET)	SLOPE PROTECTION (SQ. YARDS)	SIGNS (DOUBLE ARROW & VERTICAL CLEARANCE) (SQ. FEET)	** BRIDGE LIGHT POLES (EACH)	PEDESTRIAN PUSH BUTTONS (EACH)
13TH ST. INT. (NW Cor.)	4.6								
13TH ST. INT. (NE Cor.)	2.6								
13TH ST. INT. (SE Cor.)	2.3								
13TH ST. INT. (SW Cor.)	12.1								
14TH ST. INT. (NW Cor.)	11.8								
14TH ST. INT. (NE Cor.)	16.7								
14TH ST. INT. (SE Cor.)	16.7								
14TH ST. INT. (SW Cor.)	45.8								
14TH ST. RT. TURN	72.4								
14TH ST. RT. TURN	19.3	81.5							
NORTHEAST OF BRIDGE	15.6	26.5							
NORTHWEST OF BRIDGE	16.3	25.5							
SOUTHWEST OF BRIDGE	30.8	23							
SOUTHEAST OF BRIDGE	76.0	134			40				
NORTH OF BRIDGE IS 670 RAMP "B"			5		257				
NORTH END						50			
SOUTH END						50			
ISLAND & ON BRIDGE							51		
ON BRIDGE								6	
13TH ST. INT. (NW Cor.)									2
13TH ST. INT. (NE Cor.)									2
13TH ST. INT. (SE Cor.)									2
14TH ST. INT. (NE Cor.)									2
14TH ST. INT. (SE Cor.)									1
14TH ST. INT. (NW Cor.)									2
14TH ST. INT. (SW Cor.)									1
TOTAL:	343	291	5		257	100	51	6	12

* Includes Saw Cuts At No Direct Pay

** By Others

PAY TOTAL: ONE LUMP SUM

EROSION CONTROL		
LOCATION	SILT FENCE (LINEAR FEET)	SEDIMENT REMOVAL (CUBIC YARD)
13TH ST. INT. (SE Cor.)	24	
13TH ST. INT. (NE Cor.)	16	
14TH ST. INT. (NE Cor.)	28	
14TH ST. INT. (SE Cor.)	18	
14TH ST. INT. (NW Cor.)	64	
14TH ST. INT. (SW Cor.)	8	
NORTHEAST OF BRIDGE	30	
NORTHWEST OF BRIDGE	65	
SOUTHEAST OF BRIDGE	30	
SOUTHWEST OF BRIDGE	42	
PAY TOTAL:	325	3.0

DROP INLET CLEANOUT	
LOCATION	QUANTITY (EACH)
#154	1
PAY TOTAL:	1

CONCRETE SLOPE PROTECTION			
LOCATION	AREA LENGTH (LINEAR FEET)	AREA WIDTH (LINEAR FEET)	AREA (SQ. YARDS)
NORTH END	56	8	50
SOUTH END	56	8	50
PAY TOTAL:			100

CURVED VANE GRATE & FRAME		
LOCATION	2 X 2 QUANTITY (EACH)	4 X 2 QUANTITY (EACH)
#149		1
#151		1
#152		1
#153	1	
#154		1
Total	1	4

DESCRIPTION

DATE

MISSOURI HIGHWAYS AND TRANSPORTATION COMMISSION

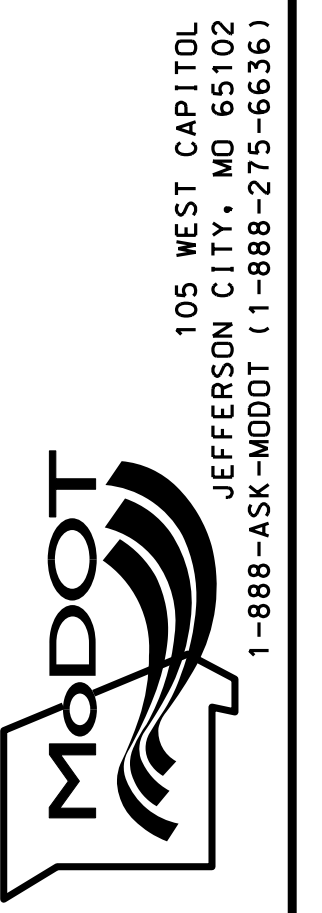

IF A SEAL IS PRESENT ON THIS SHEET IT HAS BEEN ELECTRONICALLY SEALED AND DATED.

MISSOURI HIGHWAYS AND TRANSPORTATION COMMISSION

SUMMARY OF QUANTITIES

"THIS MEDIA SHOULD NOT BE CONSIDERED A CERTIFIED DOCUMENT."

DATE PREPARED
2/6/2014

ROUTE I-670 STATE MO
DISTRICT KC SHEET NO. 3

COUNTY JACKSON

JOB NO. J412023

CONTRACT ID.

PROJECT NO.

BRIDGE NO. A08073

DATE	DESCRIPTION

DATE	DESCRIPTION

DATE	DESCRIPTION

MISSOURI HIGHWAYS AND TRANSPORTATION COMMISSION

 105 WEST CAPITOL JEFFERSON CITY, MO 65102
 1-888-ASK-MODOT (1-888-275-6636)

SIDEWALKS, CURBS, TRUCK APRON AND CONCRETE ISLAND

LOCATION	CURB RAMP (SQ. YARDS)	TRUNCATED DOMES (SQ. FEET)	12 1/2" CONC PVMT TRUCK APRON (SQ. YARDS)	SIDEWALK 4" THICK (SQ. YARDS)	SIDEWALK LINEAR GRADING (STATION)	6" TYPE A INTEGRAL CURB (LINEAR FEET)	8" RAISED CONCRETE ISLAND (SQ. YARDS)	6" TYPE S CURB (LINEAR FEET)	8" TYPE S CURB (LINEAR FEET)	3" TYPE F LOW PROFILE CURB (LINEAR FEET)
13TH ST. INT. (NW Cor.)	4.6	20								
13TH ST. INT. (NE Cor.)	2.6	10								
13TH ST. INT. (NE Cor.)	2.3	10								
13TH ST. INT. (SE Cor.)		10		10.3	0.2	41				
13TH ST. INT. (SE Cor.)		15	12.1			35		6		38
13TH ST. INT. (SW Cor.)	11.8	18								
14TH ST. INT. (NW Cor.)	16.7	24						22.5		
14TH ST. INT. (NE Cor.)	61.5	32		12.8	0.3			45		
14TH ST. INT. (SE Cor.)	1.7	12		36.3				9		
14TH ST. INT. (SW Cor.)		22		19.8			58.6			
14TH ST. RT. TURN	3.3	10		24.4				41.5	40	
NORTHEAST OF BRIDGE				15.6				26.5		
NORTHWEST OF BRIDGE				16.3					25.5	
SOUTHWEST OF BRIDGE				32.5				23		
SOUTHEAST OF BRIDGE				87.3				134		
PAY TOTAL:	104.5	182	12.1	255.3	0.5	76	58.6	308	66	38

ROADWAY RESURFACING

LOCATION	DESCRIPTION	BEGIN. STATION	END STATION	LENGTH (LINEAR FEET)	WIDTH (LINEAR FEET)	AREA (SQ. YARDS)	VOLUME (CUBIC YARDS)	COLDMILLING (SQ. YARDS)	2" BP-1 (TONS)	TACK (GALLON)
NORTH END	N/O 13TH STREET	-0+50.00	0+00.00	50	46	256	14.20	256	27.98	20.44
NORTH END	CONSTANT WIDTH	0+00.00	0+93.50	94	46	478	26.55	478	52.33	38.23
NORTH END	TAPERED WIDTH	0+93.50	2+37.36	144	43	687	38.19	687	75.26	54.99
I-670 RAMP X	E/O CHARLOTTE			51.5	35.5	203	11.29	203	22.24	16.25
13TH STREET	W/O CHARLOTTE					63	3.52	63	6.94	5.07
NORTHERN EB I-70 RAMP	E/O CHARLOTTE					55	3.06	55	6.02	4.40
SOUTHERN EB I-70 RAMP	E/O CHARLOTTE					26	1.46	26	2.87	2.10
14TH STREET	W/O CHARLOTTE					207	11.52	207	22.70	16.59
14TH STREET RIGHT TURN	W/O CHARLOTTE					140	7.78	140	15.33	11.20
SOUTH END	LESS WHITE TOPPED AREA	8+71.51	10+05.00	133	20	297	16.48	297	32.48	23.73
PAY TOTAL:								2412	264.2	200

ASPHALT DEPTH TRANSITION

LOCATION	LENGTH (LINEAR FEET)	WIDTH (LINEAR FEET)	AREA (SQ. YARDS)
NORTH END	31.54	40	140
SOUTH END	21.75	40	97
PAY TOTAL:			237

GUARDRAIL

LOCATION	BRIDGE ANCHOR SECTION	ASYMETRICAL TRANSITION SECTION	TYPE E GUARDRAIL	TYPE A GUARDRAIL
	6.5' POSTS (SAFETY BARRIER CURB) (EACH)	6.5' POSTS (EACH)	(LINEAR FEET)	(LINEAR FEET)
WB I-670	1	2	87.5	425
PAY TOTAL:	1	2	88	425

FOR INFORMATION ONLY

ESTIMATE FACTOR (TONS/CUBIC YARD)	1.971
EST. FACTOR (GAL/SQ YD)	0.08

PAVEMENT MARKING

LOCATION	4" SOLID WHITE (LINEAR FEET)	4" INT. WHITE (LINEAR FEET)	4" SOLID YELLOW (LINEAR FEET)	6" SOLID WHITE (LINEAR FEET)	24" SOLID WHITE (LINEAR FEET)	STRAIGHT ARROW (EACH)	TURN ARROW (EACH)
13TH ST. INT. (E SIDE)	90		30	70	35		
13TH ST. INT. (N SIDE)		23		93	46		
13TH ST. INT. (W SIDE)				115			
EB I-70 RAMP	6			43			
14TH ST. INT. (E SIDE)				52			
14TH ST. RAMP (N SIDE)		43		98	48		
14TH ST. INT. (W SIDE)	182			52	12		
14TH ST. RT. TURN LANE	41			38			
CHARLOTTE ST.		532					
TRUMAN RD. (N. SIDE)	324			72	36	4	4
Total	643	598	30	633	177	4	4
Total 4" White Tape:		1241					

SEEDING

	(ACRE)
PAY TOTAL:	0.1

SUMMARY OF QUANTITIES SHEET
SHEET 2 OF 3

IF A SEAL IS PRESENT ON THIS SHEET IT HAS BEEN ELECTRONICALLY SEALED AND DATED.

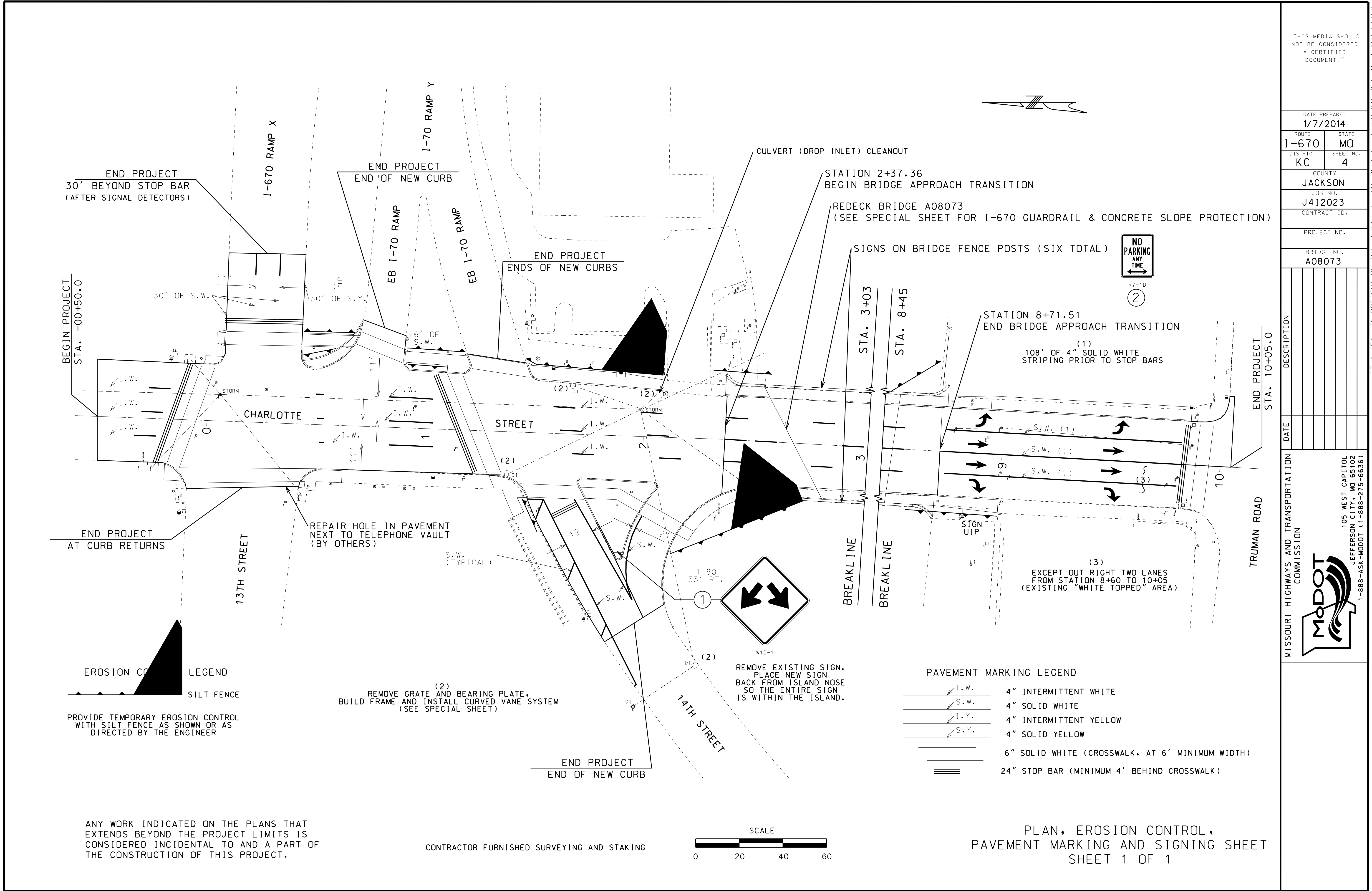

END PROJECT
30' BEYOND STOP BAR
(AFTER SIGNAL DETECTORS)

END PROJECT
END OF NEW CURB

END PROJECT
ENDS OF NEW CURBS

CULVERT (DROP INLET) CLEANOUT
STATION 2+37.36
BEGIN BRIDGE APPROACH TRANSITION

REDECK BRIDGE A08073
(SEE SPECIAL SHEET FOR I-670 GUARDRAIL & CONCRETE SLOPE PROTECTION)

SIGNS ON BRIDGE FENCE POSTS (SIX TOTAL)



STATION 8+71.51
END BRIDGE APPROACH TRANSITION

(1)
108' OF 4" SOLID WHITE
STRIPING PRIOR TO STOP BARS

BEGIN PROJECT
STA. -00+50.0

END PROJECT
STA. 10+05.0

END PROJECT
AT CURB RETURNS

REPAIR HOLE IN PAVEMENT
NEXT TO TELEPHONE VAULT
(BY OTHERS)

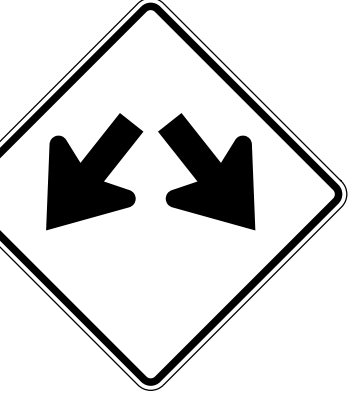

REMOVE EXISTING SIGN.
PLACE NEW SIGN
BACK FROM ISLAND NOSE
SO THE ENTIRE SIGN
IS WITHIN THE ISLAND.

(3)
EXCEPT OUT RIGHT TWO LANES
FROM STATION 8+60 TO 10+05
(EXISTING "WHITE TOPPED" AREA)

EROSION CONTROL LEGEND
SILT FENCE

PROVIDE TEMPORARY EROSION CONTROL
WITH SILT FENCE AS SHOWN OR AS
DIRECTED BY THE ENGINEER

(2)
REMOVE GRATE AND BEARING PLATE.
BUILD FRAME AND INSTALL CURVED VANE SYSTEM
(SEE SPECIAL SHEET)

PAVEMENT MARKING LEGEND

- INTERMITTENT WHITE
- SOLID WHITE
- INTERMITTENT YELLOW
- SOLID YELLOW
- SOLID WHITE (CROSSWALK, AT 6' MINIMUM WIDTH)
- STOP BAR (MINIMUM 4' BEHIND CROSSWALK)

ANY WORK INDICATED ON THE PLANS THAT
EXTENDS BEYOND THE PROJECT LIMITS IS
CONSIDERED INCIDENTAL TO AND A PART OF
THE CONSTRUCTION OF THIS PROJECT.

CONTRACTOR FURNISHED SURVEYING AND STAKING

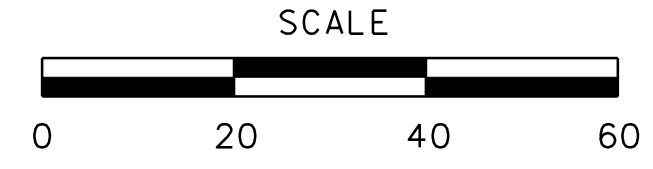

PLAN, EROSION CONTROL,
PAVEMENT MARKING AND SIGNING SHEET
SHEET 1 OF 1

"THIS MEDIA SHOULD
NOT BE CONSIDERED
A CERTIFIED
DOCUMENT."

DATE PREPARED
1/7/2014

ROUTE	STATE
I-670	MO
DISTRICT	SHEET NO.
KC	4

COUNTY
JACKSON
JOB NO.
J412023
CONTRACT ID.

PROJECT NO.

BRIDGE NO.
A08073

DATE	DESCRIPTION

MISSOURI HIGHWAYS AND TRANSPORTATION
COMMISSION

105 WEST CAPITOL
JEFFERSON CITY, MO 65102
1-888-ASK-MODOT (1-888-273-6636)

IF A SEAL IS PRESENT ON THIS SHEET IT HAS BEEN ELECTRONICALLY SEALED AND DATED.

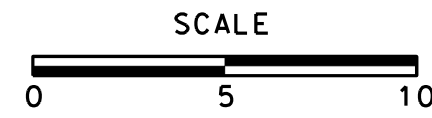

SIDEWALK SLOPES LEGEND

$1\% \leq S_1 \leq 2\%$
 $S_2 \leq 1:12$ (8.33%)

BUILD TWO PERPENDICULAR 5' RAMP

-2.13 % GRADE
 @ 35 M.P.H.

UIP
 EXISTING DOUBLE
 PULL BOX

VARIABLE HEIGHT TYPE A
 INTEGRAL CURB

NORTHERN
 EB I-70 RAMP Y

CHARLOTTE STREET

-2.00 % GRADE
 @ 35 M.P.H.

EXISTING CONDUIT

6" TYPE S CURB

3" TYPE F LOW
 PROFILE CURB

6" TYPE A
 INTEGRAL CURB

12.5" PAVEMENT
 (TRUCK APRON)

VARIABLE HEIGHT TYPE A
 INTEGRAL CURB

BUILD 5' WIDE SIDEWALK CUT THROUGH.
 BUILD PERPENDICULAR RAMP IN THE TRUCK APRON.

- (1) REPLACE TWO PEDESTRIAN PUSH BUTTONS WITH ONLY ONE ON THE EAST SIDE OF THE POST
- (2) REPLACE TWO PEDESTRIAN PUSH BUTTONS WITH ONLY ONE ON THE SOUTH SIDE OF THE POST
- (3) REPLACE TWO PEDESTRIAN PUSH BUTTONS WITH ONE (INCLUDING EXTENSION) ON THE EAST SIDE OF THE POST

TRAFFIC SIGNALS LEGEND			
	EXISTING CONTROLLER		EXISTING PULL BOX
	EXISTING POWER SUPPLY/SOURCE		PROPOSED PEDESTRIAN PUSH BUTTON POST
	EXISTING SIGNAL HEAD (PEDESTRIAN)		PROPOSED PEDESTRIAN PUSH BUTTON NUMBER
	EXISTING SIGNAL HEAD NUMBER		6'x30' DETECTOR LOOPS
	EXISTING CONDUIT		CONDUIT PUSHED
			CONDUIT TRENCHED

THEORETICAL SIDEWALK
 CENTERLINE

BUILD PERPENDICULAR RAMP
 FOR S/N BOUND ONLY

BUILD BLENDED TRANSITION
 RAMPS IN LINE WITH CROSSWALKS

CHARLOTTE STREET
 AT 13TH STREET

THEORETICAL
 SIDEWALK CENTERLINE

SPECIAL SHEET 1 OF 7
 PEDESTRIAN SIGNALS
 AND SIDEWALK PLAN

"THIS MEDIA SHOULD
 NOT BE CONSIDERED
 A CERTIFIED
 DOCUMENT."

DATE PREPARED		1/7/2014	
ROUTE	STATE	DISTRICT	SHEET NO.
I-670	MO	KC	5
COUNTY			
JACKSON			
JOB NO.			
J412023			
CONTRACT ID.			
PROJECT NO.			
BRIDGE NO.			
A08073			

DATE	DESCRIPTION

MISSOURI HIGHWAYS AND TRANSPORTATION COMMISSION

105 WEST CAPITOL
 JEFFERSON CITY, MO 65102
 1-888-ASK-MODOT (1-888-273-6636)

IF A SEAL IS PRESENT ON THIS SHEET IT HAS BEEN ELECTRONICALLY SEALED AND DATED.

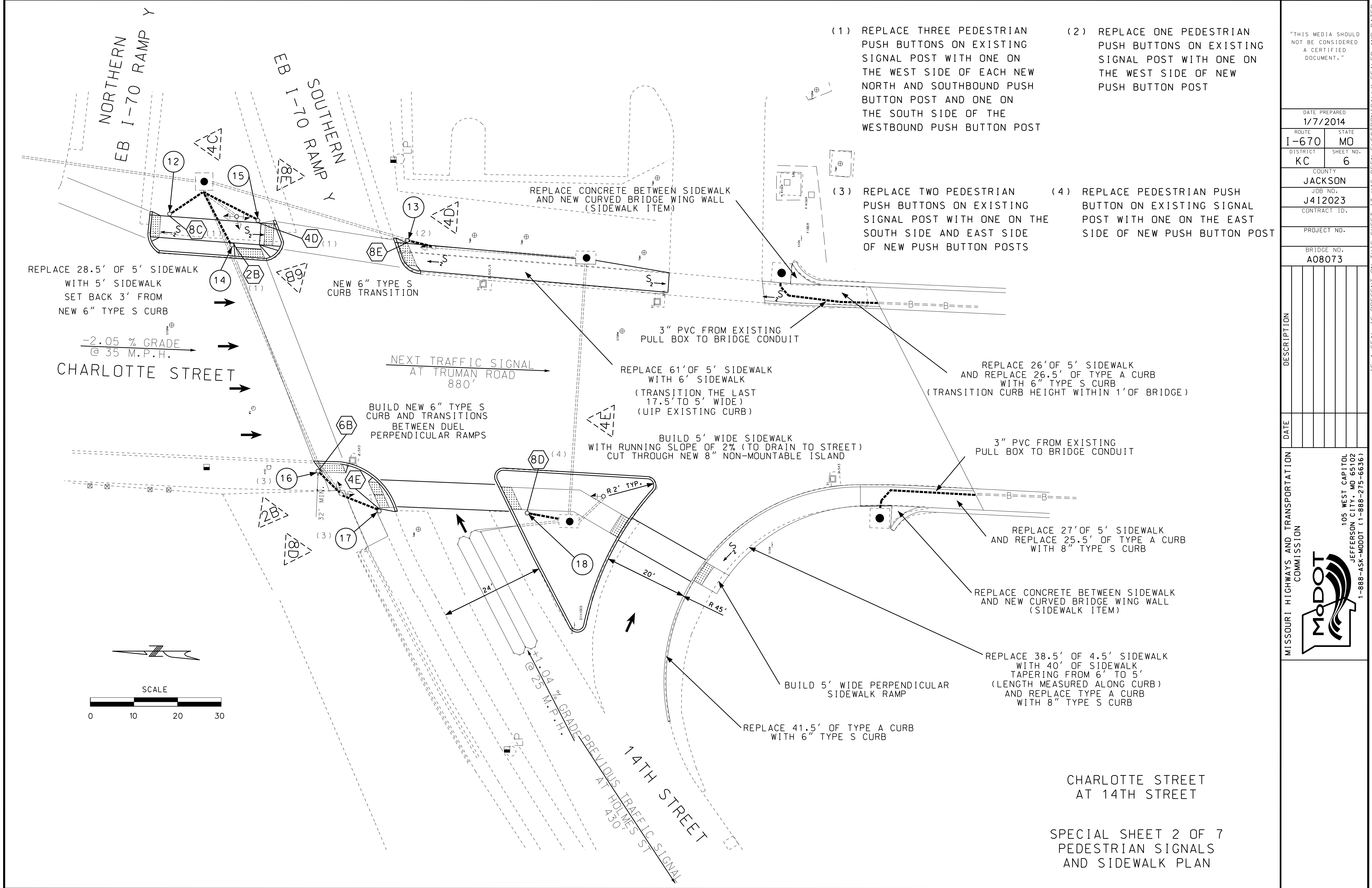

- (1) REPLACE THREE PEDESTRIAN PUSH BUTTONS ON EXISTING SIGNAL POST WITH ONE ON THE WEST SIDE OF EACH NEW NORTH AND SOUTHBOUND PUSH BUTTON POST AND ONE ON THE SOUTH SIDE OF THE WESTBOUND PUSH BUTTON POST
- (2) REPLACE ONE PEDESTRIAN PUSH BUTTON ON EXISTING SIGNAL POST WITH ONE ON THE WEST SIDE OF NEW PUSH BUTTON POST
- (3) REPLACE TWO PEDESTRIAN PUSH BUTTONS ON EXISTING SIGNAL POST WITH ONE ON THE SOUTH SIDE AND EAST SIDE OF NEW PUSH BUTTON POSTS
- (4) REPLACE PEDESTRIAN PUSH BUTTON ON EXISTING SIGNAL POST WITH ONE ON THE EAST SIDE OF NEW PUSH BUTTON POST

"THIS MEDIA SHOULD NOT BE CONSIDERED A CERTIFIED DOCUMENT."

DATE PREPARED 1/7/2014	
ROUTE I-670	STATE MO
DISTRICT KC	SHEET NO. 6
COUNTY JACKSON	
JOB NO. J412023	
CONTRACT ID.	
PROJECT NO.	
BRIDGE NO. A08073	

DESCRIPTION	DATE

MISSOURI HIGHWAYS AND TRANSPORTATION COMMISSION

105 WEST CAPITOL
JEFFERSON CITY, MO 65102
1-888-ASK-MODOT (1-888-273-6636)

IF A SEAL IS PRESENT ON THIS SHEET IT HAS BEEN ELECTRONICALLY SEALED AND DATED.

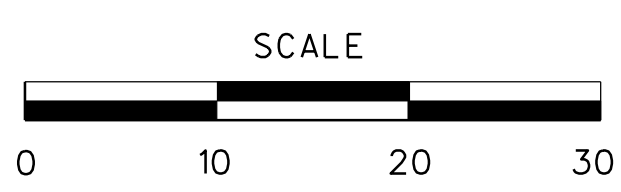

CHARLOTTE STREET AT 14TH STREET
SPECIAL SHEET 2 OF 7
PEDESTRIAN SIGNALS AND SIDEWALK PLAN

"THIS MEDIA SHOULD NOT BE CONSIDERED A CERTIFIED DOCUMENT."

DATE PREPARED
1/7/2014

ROUTE STATE
I-670 MO
DISTRICT SHEET NO.
KC 7

COUNTY
JACKSON
JOB NO.
J412023
CONTRACT ID.

PROJECT NO.

BRIDGE NO.
A08073

DATE	DESCRIPTION

MISSOURI HIGHWAYS AND TRANSPORTATION COMMISSION



105 WEST CAPITOL
JEFFERSON CITY, MO 65102
1-888-ASK-MODOT (1-888-273-6636)

IF A SEAL IS PRESENT ON THIS SHEET IT HAS BEEN ELECTRONICALLY SEALED AND DATED.

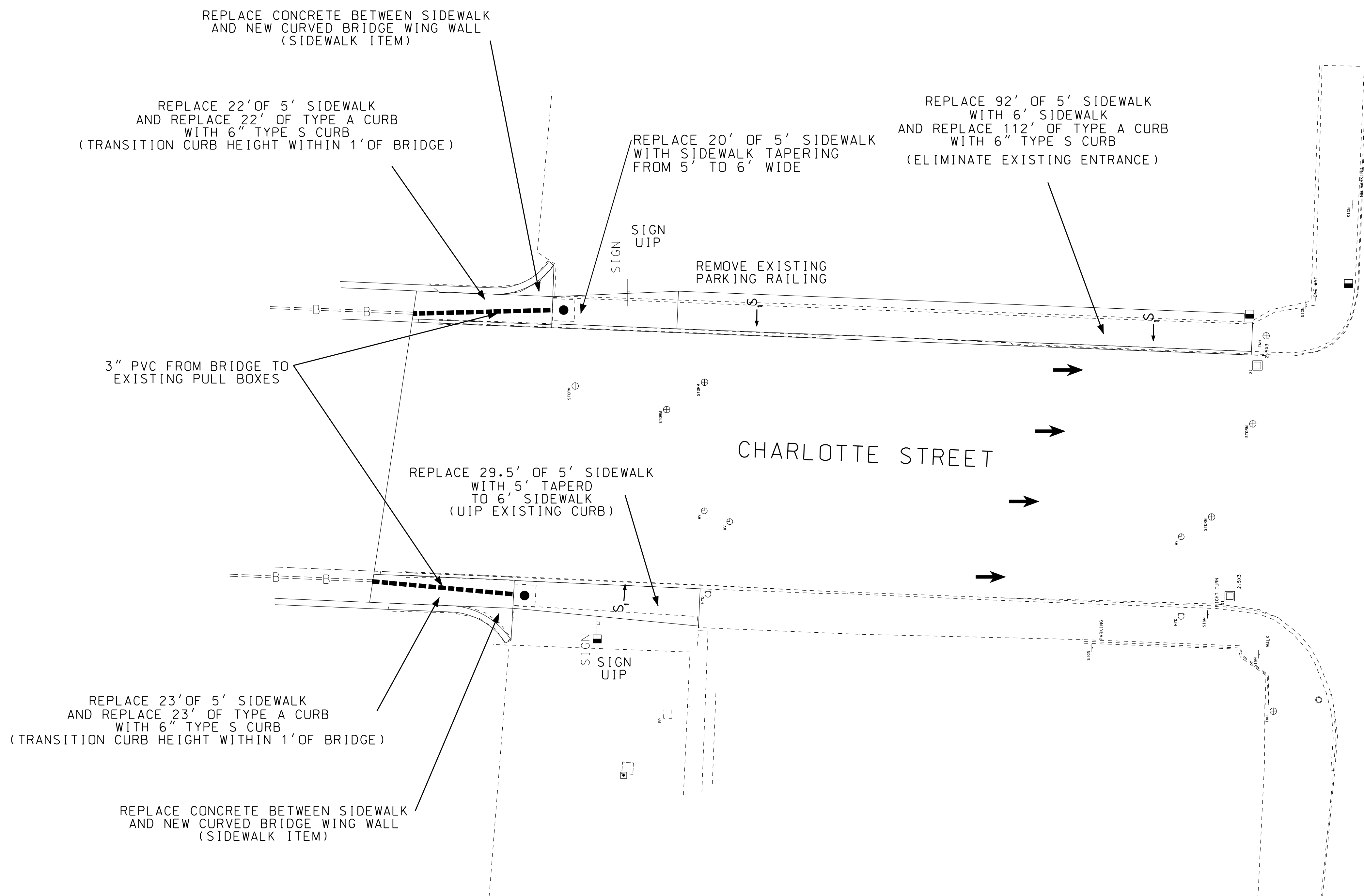

TRUMAN ROAD

CHARLOTTE STREET

CHARLOTTE STREET
SOUTH OF BRIDGE
SPECIAL SHEET 3 OF 7
CONDUIT, CURB AND SIDEWALK PLAN

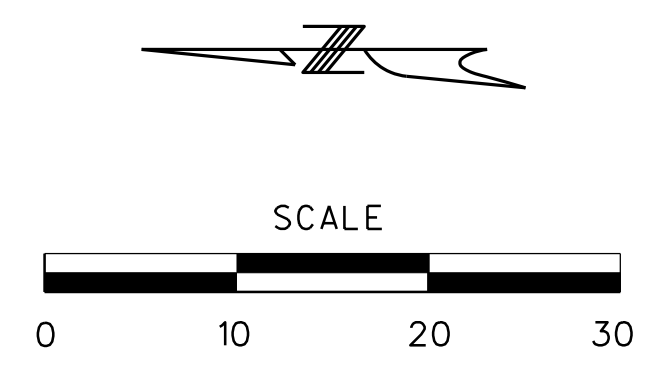

GENERAL NOTES:

ALL POST WIRE OUTLETS SHALL BE DEBURRED AND EQUIPPED WITH BUSHINGS.

BACKPLATES NOT SHOWN IN MOUNTING DIAGRAMS FOR CLARITY.

POSTS SHALL BE GROUNDED WITH #6 AWG BARE COPPER WIRE FROM GROUNDING BUSHING ON CONDUIT TO GROUNDING LUG IN POST BASE IF STEEL CONDUIT IS USED. IF PVC CONDUIT IS USED, PROVIDE #6 AWG BARE COPPER WIRE FROM GROUNDING LUG IN POST TO POWER SUPPLY GROUND BUSS IN CONTROLLER CABINET.

SEE STANDARD PLAN 902.30 FOR BASE DETAILS AND CONDUIT LOCATIONS.

SEE SIGNAL SHEET D-37A FOR APPROPRIATE PEDESTRIAN SIGNS. PEDESTRIAN SIGNS ARE TO BE MOUNTED WITH A SIGN BRACKET ASSEMBLY AND SHALL BE VERTICAL.

"THIS MEDIA SHOULD NOT BE CONSIDERED A CERTIFIED DOCUMENT."

DATE PREPARED
1/7/2014

ROUTE STATE
I-670 MO

DISTRICT SHEET NO.
KC 8

COUNTY
JACKSON

JOB NO.
J412023

CONTRACT ID.

PROJECT NO.

BRIDGE NO.
A08073

DESCRIPTION

DATE

DATE

DATE

DATE

DATE

DATE

DATE

DATE

DATE

DATE

DATE

DATE

DATE

DATE

DATE

DATE

DATE

DATE

DATE

DATE

DATE

DATE

DATE

DATE

DATE

DATE

DATE

DATE

DATE

DATE

DATE

DATE

DATE

DATE

DATE

DATE

DATE

DATE

DATE

DATE

DATE

DATE

DATE

DATE

DATE

DATE

DATE

DATE

DATE

DATE

DATE

DATE

DATE

DATE

DATE

DATE

DATE

DATE

DATE

DATE

DATE

DATE

DATE

DATE

DATE

DATE

DATE

IF A SEAL IS PRESENT ON THIS SHEET IT HAS BEEN ELECTRONICALLY SEALED AND DATED.

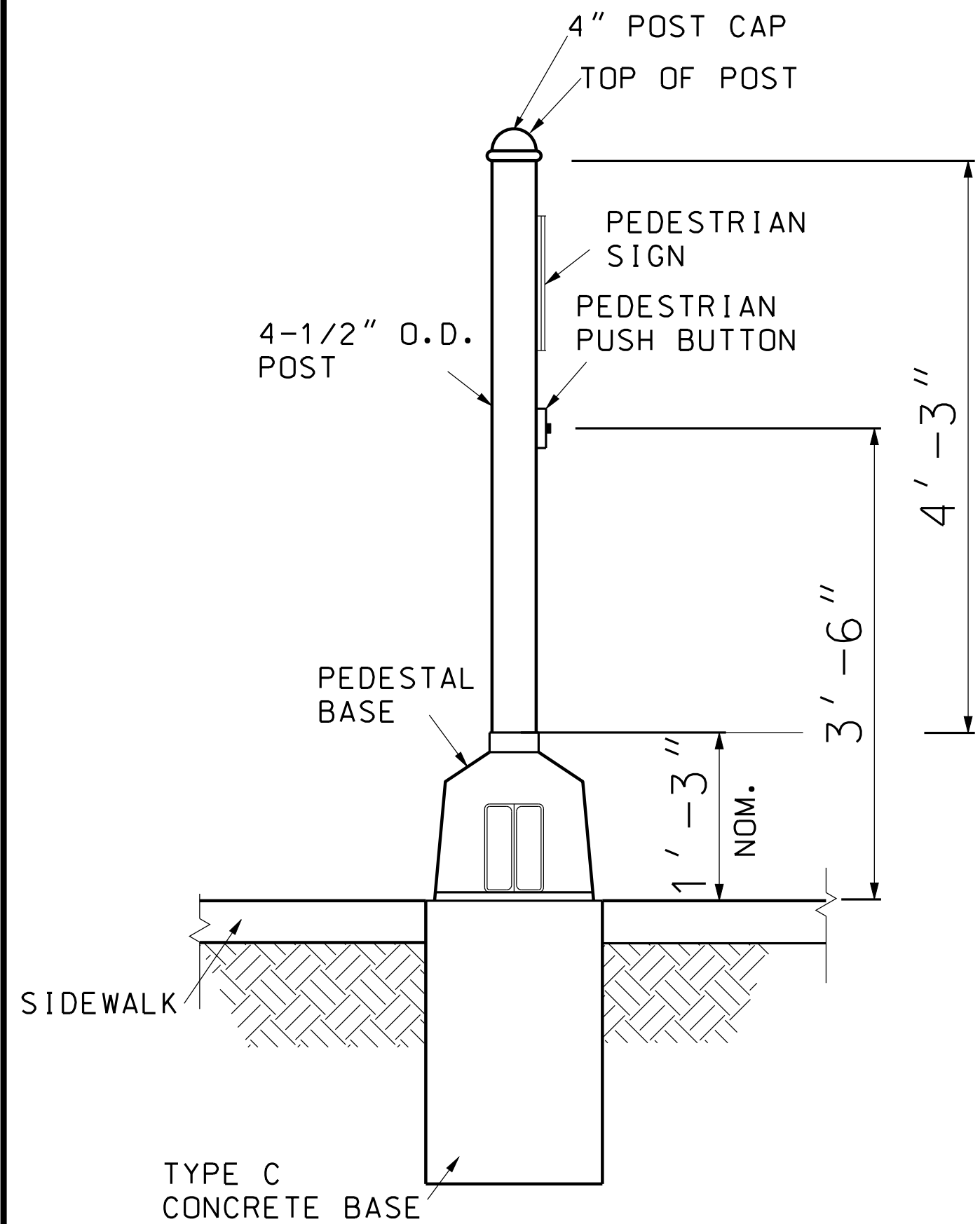

FLUSH WITH SIDEWALK

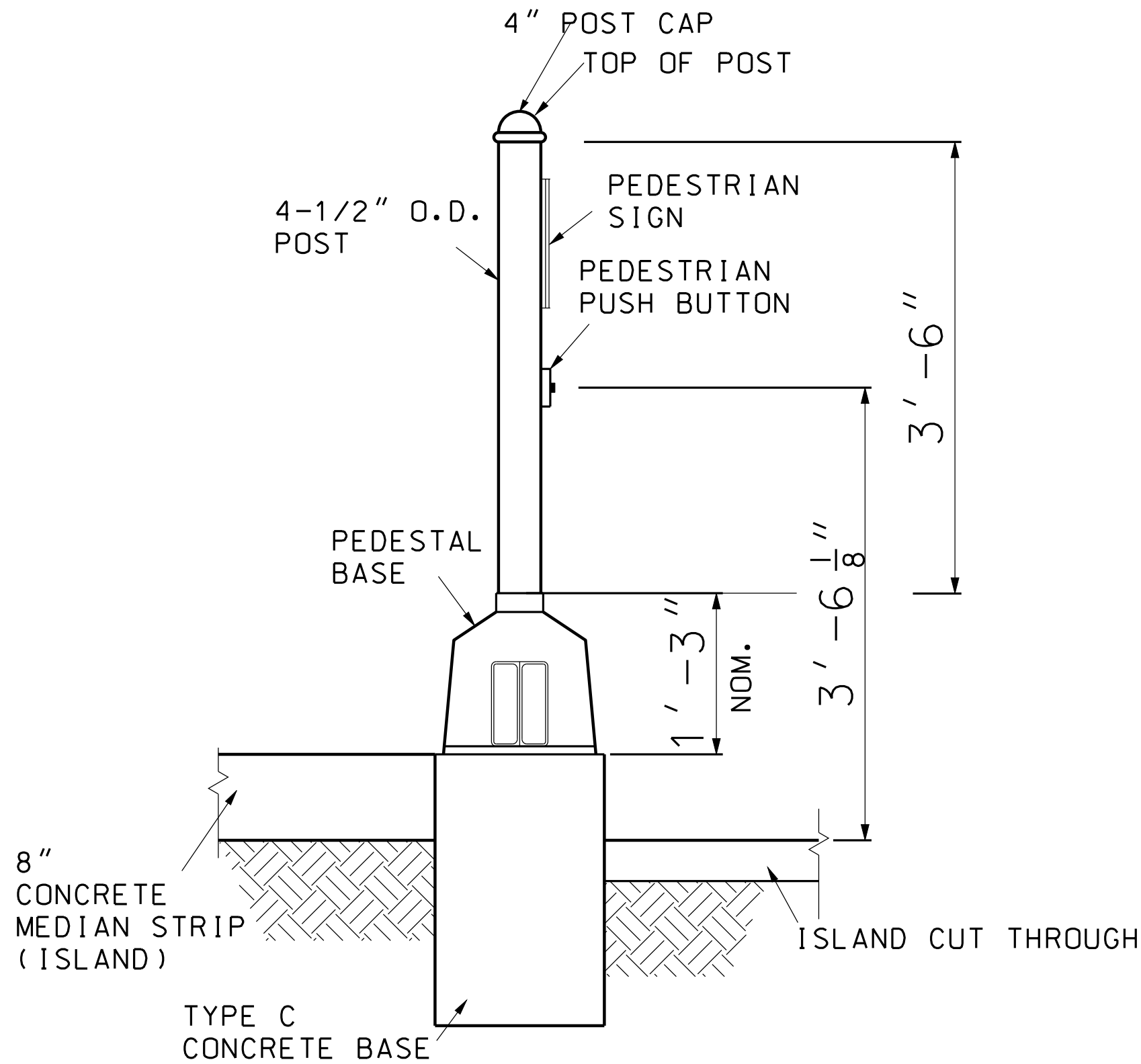

FLUSH WITH TOP OF 8" ISLAND

SPECIAL SHEET
SHEET 4 OF 7
TRAFFIC SIGNALS
PEDESTRIAN PUSH BUTTON
SIGNAL POST

MISSOURI HIGHWAYS AND TRANSPORTATION COMMISSION

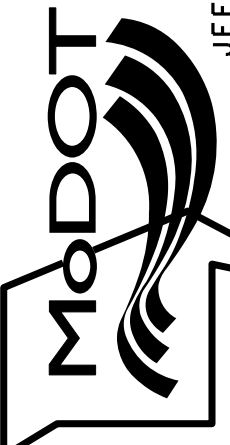

105 WEST CAPITOL
JEFFERSON CITY, MO 65102
1-888-ASK-MODOT (1-888-273-6636)

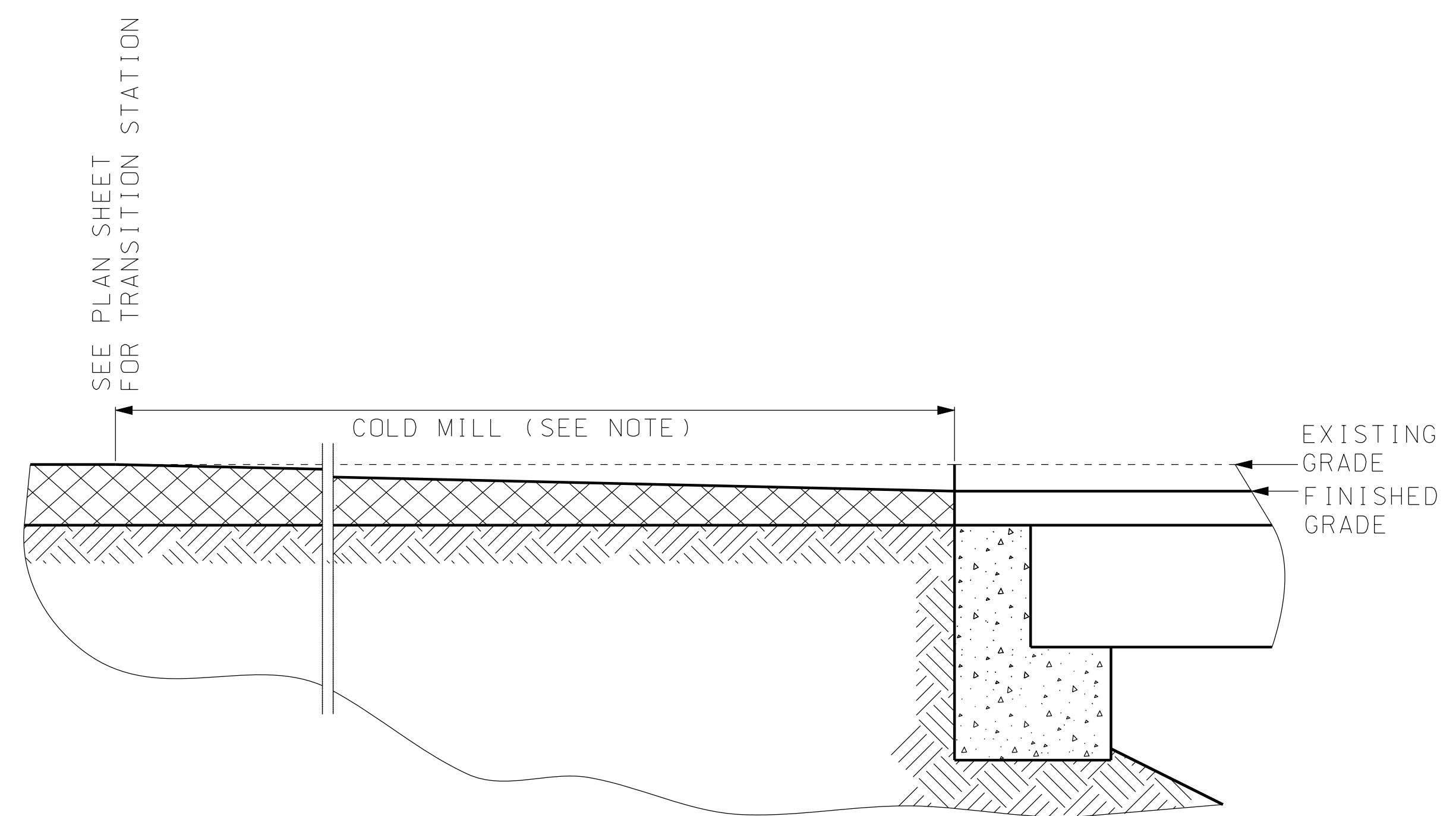

DEPTH TRANSITION FOR LOWER GRADE

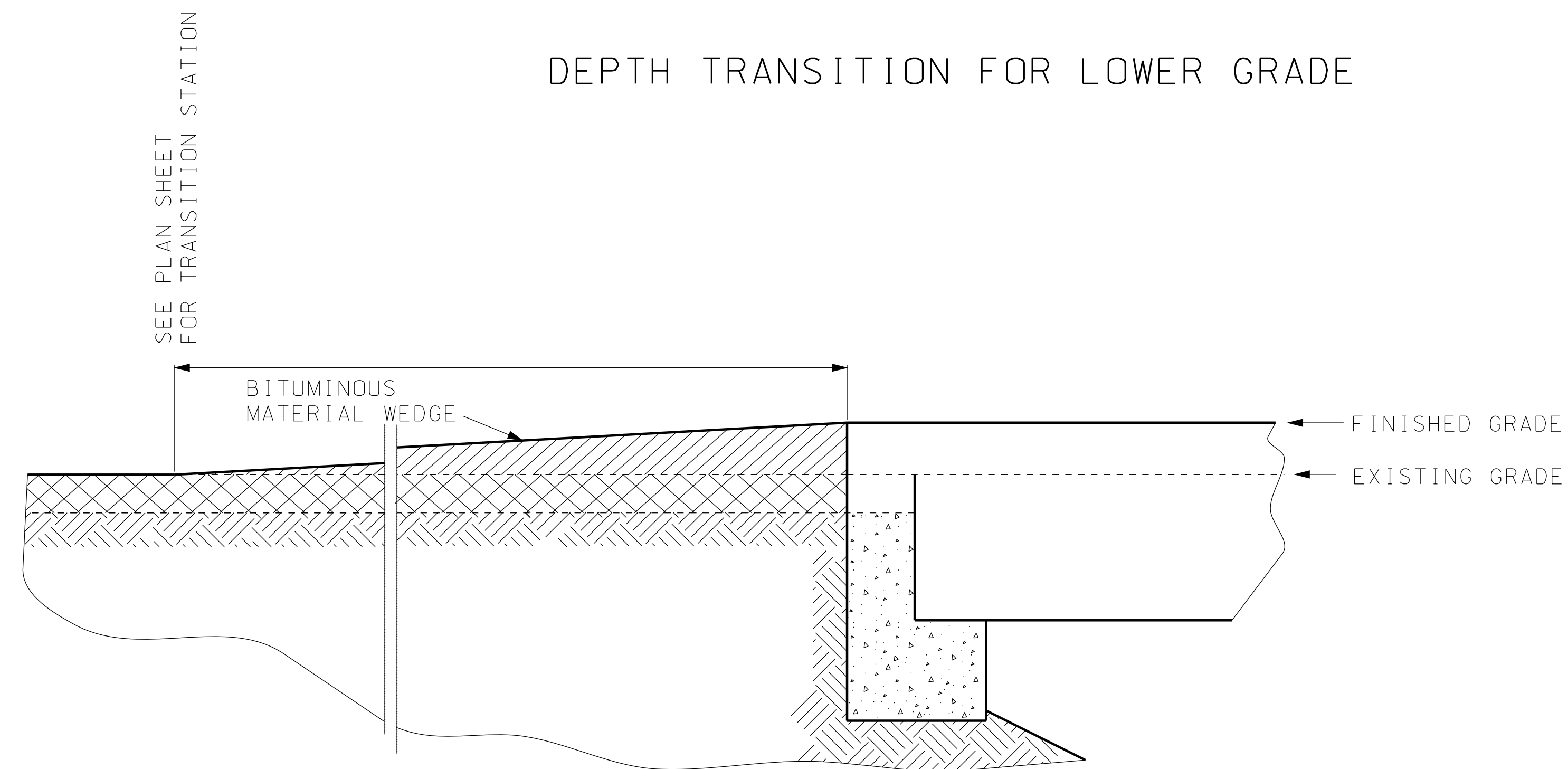

DEPTH TRANSITION FOR HIGHER GRADE

NOTES:

SMALL VARIANCES BETWEEN EXISTING AND FINISHED GRADE MAY BE MITIGATED, WITHIN THE PARAMETERS SPECIFIED ON BRIDGE PLANS, BY ADJUSTMENT OF THE HAUNCH.

ANY NECESSARY COLD MILLING OPERATION IS INCLUDED IN THE UNIT COST FOR ASPHALT DEPTH TRANSITION AT NO DIRECT COST.

"THIS MEDIA SHOULD NOT BE CONSIDERED A CERTIFIED DOCUMENT."

DATE PREPARED 1/7/2014	
ROUTE I-670	STATE MO
DISTRICT KC	SHEET NO. 9
COUNTY JACKSON	
JOB NO. J412023	
CONTRACT ID.	
PROJECT NO.	
BRIDGE NO. A08073	

DATE	DESCRIPTION

MISSOURI HIGHWAYS AND TRANSPORTATION COMMISSION

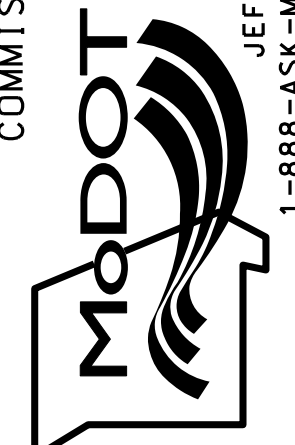

105 WEST CAPITOL
JEFFERSON CITY, MO 65102
1-888-ASK-MODOT (1-888-273-6636)

IF A SEAL IS PRESENT ON THIS SHEET IT HAS BEEN ELECTRONICALLY SEALED AND DATED.

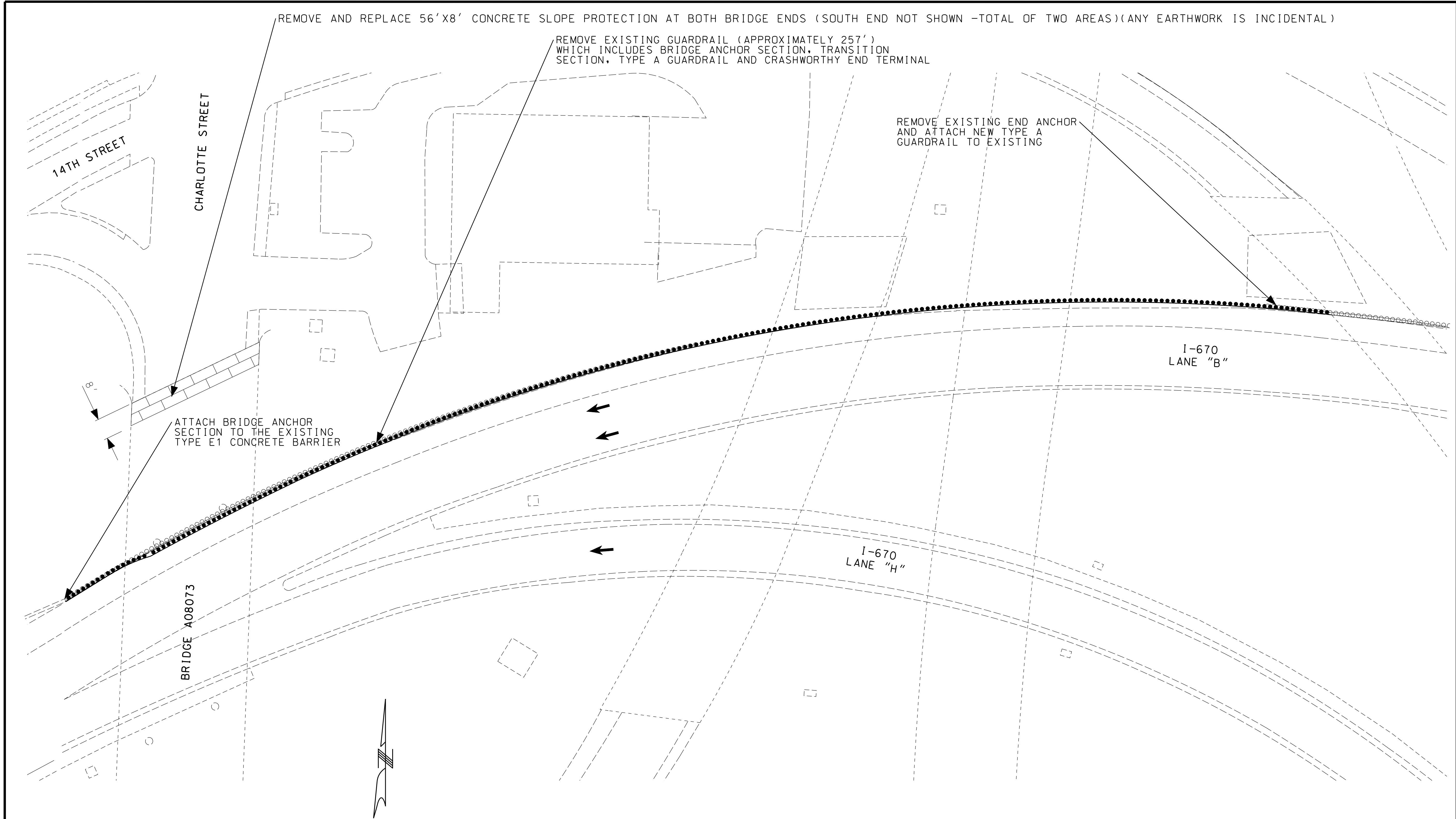

"THIS MEDIA SHOULD NOT BE CONSIDERED A CERTIFIED DOCUMENT."

DATE PREPARED	1/7/2014		
ROUTE	I-670	STATE	MO
DISTRICT	KC	SHEET NO.	10
COUNTY	JACKSON		
JOB NO.	J412023		
CONTRACT ID.			
PROJECT NO.			
BRIDGE NO.	A08073		

DATE	DESCRIPTION

MISSOURI HIGHWAYS AND TRANSPORTATION COMMISSION

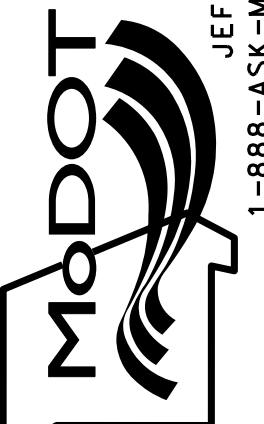

105 WEST CAPITOL
JEFFERSON CITY, MO 65102
1-888-ASK-MDOT (1-888-273-6636)

I-670 LANE "B"
BUILD 1 EA - BRIDGE ANCHOR SECTION
1 EA - TRANSITION SECTION
87.5' TYPE E GUARDRAIL *
1 EA - TRANSITION SECTION
425' TYPE A GUARDRAIL

* TYPE E GUARDRAIL BACK OF POST TO BE 2' CLEAR OF BRIDGE PIERS. TRANSITION FIRST 25' (EAST OF PIERS) TYPE A GUARDRAIL BACK TO EDGE OF SHOULDER.

SPECIAL SHEET 6 OF 7

I-670 GUARDRAIL
AND BRIDGE SLOPE PROTECTION REPAIR

IF A SEAL IS PRESENT ON THIS SHEET IT HAS BEEN ELECTRONICALLY SEALED AND DATED.

153
 CURB INLET WITH D.I.
 2' X 2' OPENING
 BUILD 1 - 2' X 2' CURVED
 VANE GRATE AND FRAME

154
 D.I. ONLY
 3' X 2' OPENING
 BUILD 1 - 4' X 2' CURVED
 VANE GRATE AND FRAME

151
 D.I. ONLY
 3' X 2' OPENING
 BUILD 1 - 4' X 2' CURVED
 VANE GRATE AND FRAME

152
 D.I. ONLY
 3' X 2' OPENING
 BUILD 1 - 4' X 2' CURVED
 VANE GRATE AND FRAME

149
 CURB INLET WITH D.I.
 3' X 2' OPENING
 BUILD 1 - 4' X 2' CURVED
 VANE GRATE AND FRAME

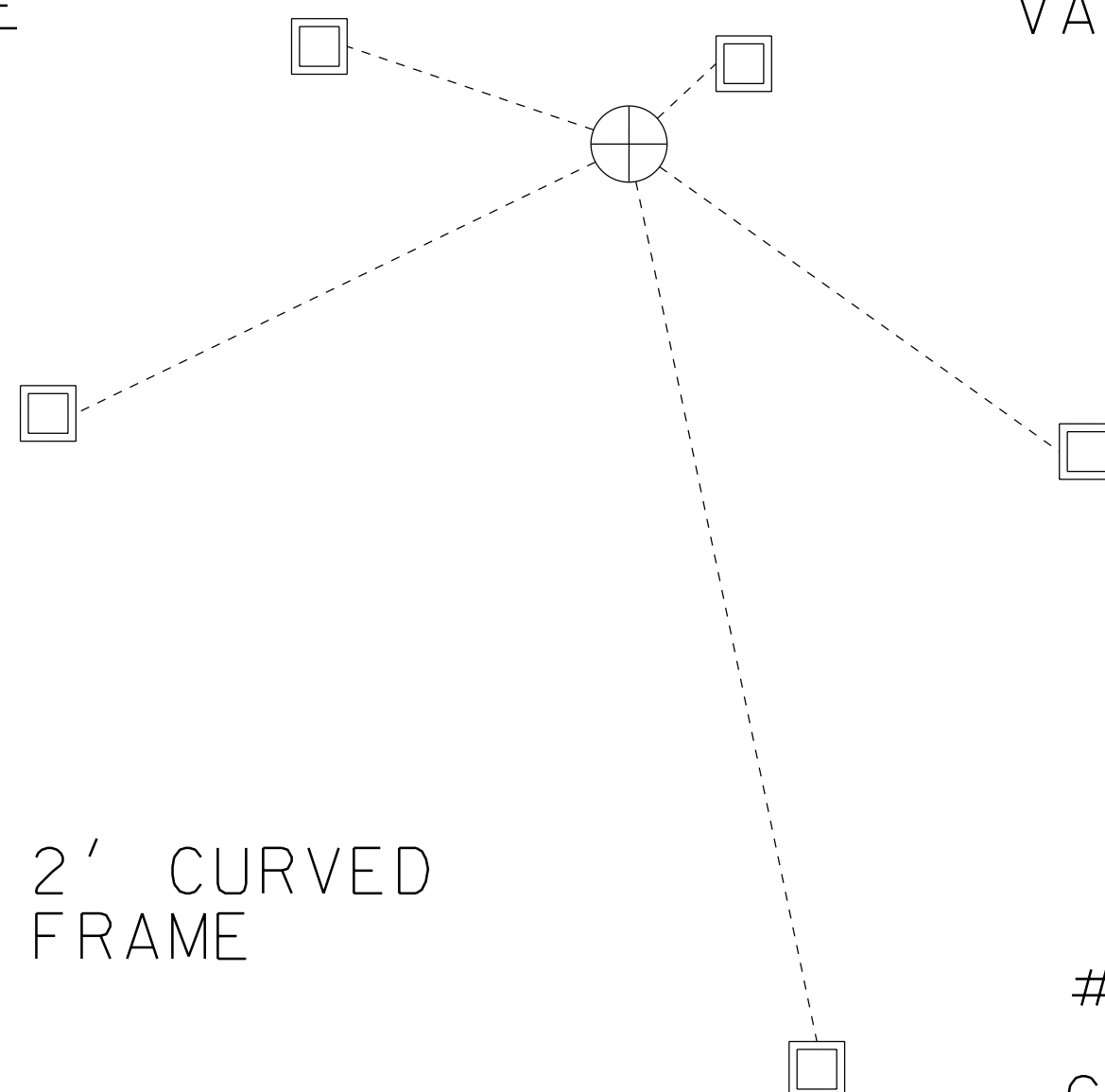
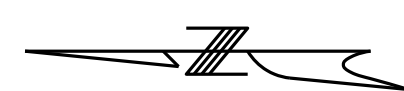

REMOVE EXISTING GRATE AND BEARING PLATE, EXTEND INLET
 WALLS UP AND REPLACE WITH CURVED VANE SYSTEM

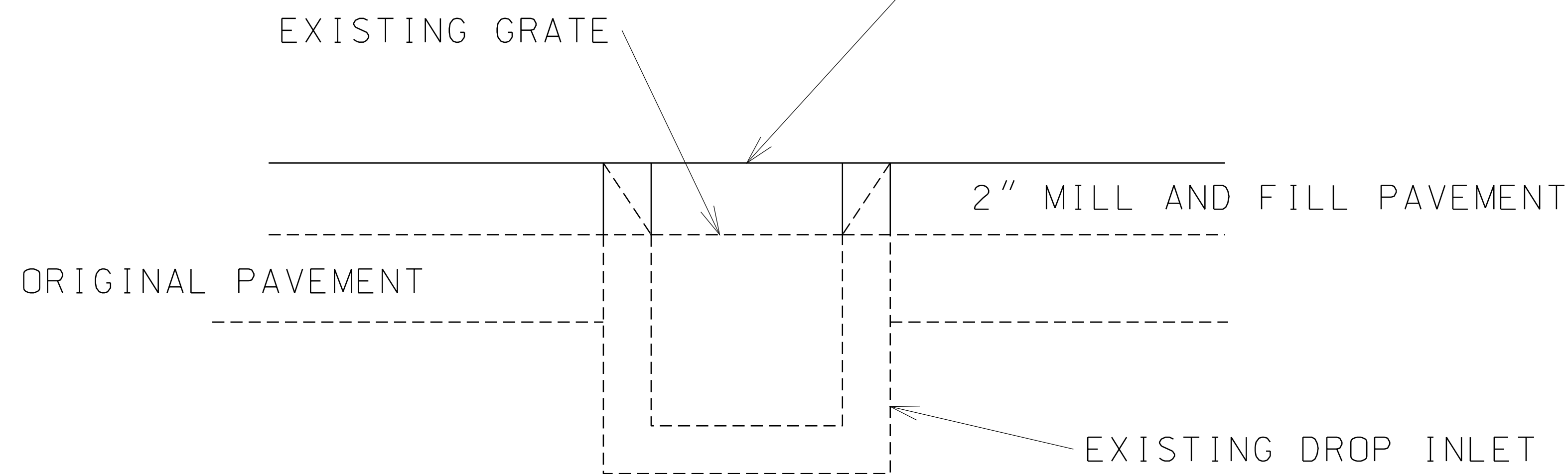

CHARLOTTE STREET
 AT 14TH STREET

DO NOT DISTURB EXISTING DRAINAGE CHANNEL

SPECIAL SHEET 7 OF 7
 DROP INLET GRATES REPLACEMENT

"THIS MEDIA SHOULD
 NOT BE CONSIDERED
 A CERTIFIED
 DOCUMENT."

DATE PREPARED
 1/7/2014

ROUTE STATE
 I-670 MO

DISTRICT SHEET NO.
 KC 11

COUNTY
 JACKSON

JOB NO.
 J412023

CONTRACT ID.

PROJECT NO.

BRIDGE NO.

A08073

DESCRIPTION

DATE

DATE

DATE

DATE

DATE

DATE

DATE

DATE

DATE

DATE

DATE

DATE

DATE

DATE

DATE

DATE

DATE

DATE

DATE

DATE

DATE

DATE

DATE

DATE

DATE

DATE

DATE

DATE

DATE

DATE

DATE

DATE

DATE

DATE

DATE

DATE

DATE

DATE

DATE

DATE

DATE

DATE

DATE

DATE

DATE

DATE

DATE

DATE

DATE

DATE

DATE

DATE

DATE

DATE

DATE

DATE

DATE

DATE

DATE

DATE

DATE

DATE

DATE

DATE

DATE

DATE

DATE

DATE

IF A SEAL IS PRESENT ON THIS SHEET IT HAS BEEN ELECTRONICALLY SEALED AND DATED.

MISSOURI HIGHWAYS AND TRANSPORTATION
 COMMISSION

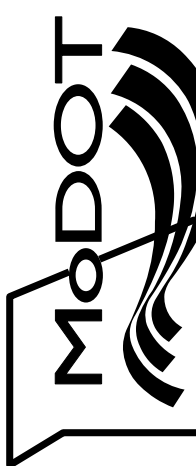

105 WEST CAPITOL
 JEFFERSON CITY, MO 65102
 1-888-ASK-MODOT (1-888-273-6636)

Traffic Control Legend, Sign Spacing, Device Spacing, Channelizing Taper Lengths And Recommended Maximum Speed Reductions

"THIS MEDIA SHOULD NOT BE CONSIDERED A CERTIFIED DOCUMENT."

TAPER LENGTHS AND SPACING OF CHANNELIZING DEVICES						
SPEED (P) MPH	MINIMUM TAPER LENGTHS (L) FOR LANE WIDTHS (W)			MINIMUM TAPER SHOULDER (T1)	MAXIMUM CHANNELIZER SPACING	
	10 FT	11 FT	12 FT		THROUGH TAPER	THROUGH WORK AREA
0-35	205 FT	225 FT	245 FT	70	35 FT	50 FT
40-45	450 FT	495 FT	540 FT	150	40 FT	100 FT
50-55	550 FT	605 FT	660 FT	185	50 FT	100 FT
60-70	700 FT	770 FT	840 FT	235	60 FT	100 FT

TAPER LENGTH (L)
 L = W X P FOR 40 MPH OR MORE
 L = $\frac{WP^2}{60}$ FOR 35 MPH OR LESS
 L = TAPER LENGTH IN FEET
 W = LATERAL SHIFT IN FEET
 P = POSTED SPEED PRIOR TO ROAD WORK IN MPH

TRAFFIC CONTROL LEGEND

<ul style="list-style-type: none"> SIGN (SINGLE SIDED) FLAGGER CHANNELIZER PROTECTIVE VEHICLE WITH WORK SIGN, FLASHING ARROW PANEL AND TRUCK MOUNTED ATTENUATOR. 	<ul style="list-style-type: none"> FLASHING ARROW PANEL CHANGEABLE MESSAGE BOARD BARRICADE SEE STANDARD PLAN 612.20 FOR SAND FILLED IMPACT ATTENUATOR DETAILS
--	---

SIGN SPACING FOR ADVANCE SIGN SERIES (1) (2)		
SPEED (P) MPH	NON-DIVIDED HIGHWAYS (S)	
	DIVIDED HIGHWAYS (S)	
0-35	200 FT	200 FT
40-45	350 FT	500 FT
50-55	500 FT	1000 FT
60-70	SA-1000 FT, SB-1500 FT, SC-2640 FT **	

LONGITUDINAL BUFFER SPACE	
SPEED (P) MPH	BUFFER SPACE (FEET)
0-35	250
40-45	360
50-55	495
60-70	730

EPG TABLE 616.29 RECOMMENDED MAXIMUM SPEED REDUCTIONS	
ACTIVITY (I.E. WORKERS, EQUIPMENT OR MATERIAL) LOCATION	RECOMMENDED WORK ZONE SPEED REDUCTION (WHEN APPLICABLE)
10 FT. BEYOND EDGE OF TRAVELWAY TO EDGE OF RIGHT OF WAY	NO SPEED REDUCTION
IN TRAFFIC LANE OR WITHIN 10FT. OF THE TRAFFIC LANE	10 MPH
HEAD-TO-HEAD ON MULTILANE	10 MPH

SPECIAL CIRCUMSTANCES WITHIN A TEMPORARY TRAFFIC CONTROL WORK ZONE MAY WARRANT A LOWER SPEED LIMIT THAN RECOMMENDED ABOVE. ALL SPEED LIMIT REDUCTIONS GREATER THAN 10 MPH SHALL BE DOCUMENTED, SUBMITTED TO AND APPROVED BY THE DISTRICT WORK ZONE COORDINATOR.

** THE SA DIMENSION IS THE DISTANCE FROM THE TRANSITION OR POINT OF RESTRICTION TO THE FIRST SIGN.
 THE SB DIMENSION IS THE DISTANCE BETWEEN THE FIRST AND SECOND SIGNS.
 THE SC DIMENSION IS THE DISTANCE BETWEEN THE SECOND AND THIRD SIGNS.
 (THE "FIRST SIGN" IS THE SIGN IN A THREE-SIGN SERIES THAT IS CLOSEST TO THE TEMPORARY TRAFFIC CONTROL ZONE. THE "THIRD SIGN" IS THE SIGN THAT IS FURTHEST UPSTREAM FROM THE TEMPORARY TRAFFIC CONTROL ZONE)

DETAILS NOTES:

DIMENSIONS IN FEET UNLESS OTHERWISE NOTED.

- (1) SPACING BETWEEN SIGNS AND SPACING BETWEEN LAST SIGN AND FLAGGER, BEGINNING OF TAPER, OR SIGNED CONDITION
- (2) SPACINGS MAY BE ADJUSTED AS NECESSARY TO MEET FIELD CONDITIONS
- (3) TAPER LENGTHS SHOWN INCLUDE LENGTH REQUIRED FOR LANE AND 10 FT SHOULDER
- (4) CONCRETE BARRIER MAY BE INSTALLED AT AN 8:1 FLARE RATE FROM THE SHOULDER POINT TO THE LIMITS OF THE CLEAR ZONE WHERE THE SIDE SLOPE IS 6:1 OR FLATTER

GENERAL NOTES:

1. SEE STANDARD PLAN 616.10 FOR DETAILS AND ITEMS NOT SHOWN.
2. EXISTING SIGNS SHALL BE COVERED DURING WORKING HOURS ONLY IF IN CONFLICT WITH TRAFFIC CONTROL PLANS.
3. NO DIRECT PAYMENT WILL BE MADE FOR RELOCATING, COVERING, UNCOVERING OR REMOVING SIGNS.
4. CONES ALLOWABLE FOR DAYTIME OPERATIONS ONLY.
5. LOCATE FLASHING ARROW PANEL AT BEGINNING OF TAPER WHEN FEASIBLE, ARROW PANELS ARE ALWAYS LOCATED BEHIND CHANNELIZERS OR CONES.

TAPER LENGTHS AND END TREATMENTS FOR CONCRETE BARRIER				
SPEED (P) MPH	MINIMUM TAPER LENGTHS FOR LANE WIDTHS (3)			END TREATMENT (4)
	10 FT	11 FT	12 FT	
< 40	160 FT	168 FT	176 FT	BARRIER HEIGHT TRANSITION
≥ 40	160 FT	168 FT	176 FT	APPROVED CRASH CUSHION

TEMPORARY
TRAFFIC CONTROL
SHEET 1 OF 10

DATE PREPARED
1/7/2014

ROUTE I-670	STATE MO
DISTRICT KC	SHEET NO. 12

COUNTY
JACKSON

JOB NO.
J412023

CONTRACT ID.

PROJECT NO.

BRIDGE NO.
A08073

REV.	DESCRIPTION	DATE

MISSOURI HIGHWAYS AND TRANSPORTATION COMMISSION

105 WEST CAPITOL
JEFFERSON CITY, MO 65102
1-888-ASK-MODOT (1-888-275-6636)

IF A SEAL IS PRESENT ON THIS SHEET IT HAS BEEN ELECTRONICALLY SEALED AND DATED.

"THIS MEDIA SHOULD NOT BE CONSIDERED A CERTIFIED DOCUMENT."

DATE PREPARED
1/7/2014

ROUTE I-670 STATE MO

DISTRICT KC SHEET NO. 13

COUNTY JACKSON

JOB NO. J412023

CONTRACT ID.

PROJECT NO.

BRIDGE NO. A08073

DATE	DESCRIPTION

MISSOURI HIGHWAYS AND TRANSPORTATION COMMISSION



105 WEST CAPITOL
JEFFERSON CITY, MO 65102
1-888-ASK-MODOT (1-888-273-6636)

IF A SEAL IS PRESENT ON THIS SHEET IT HAS BEEN ELECTRONICALLY SEALED AND DATED.

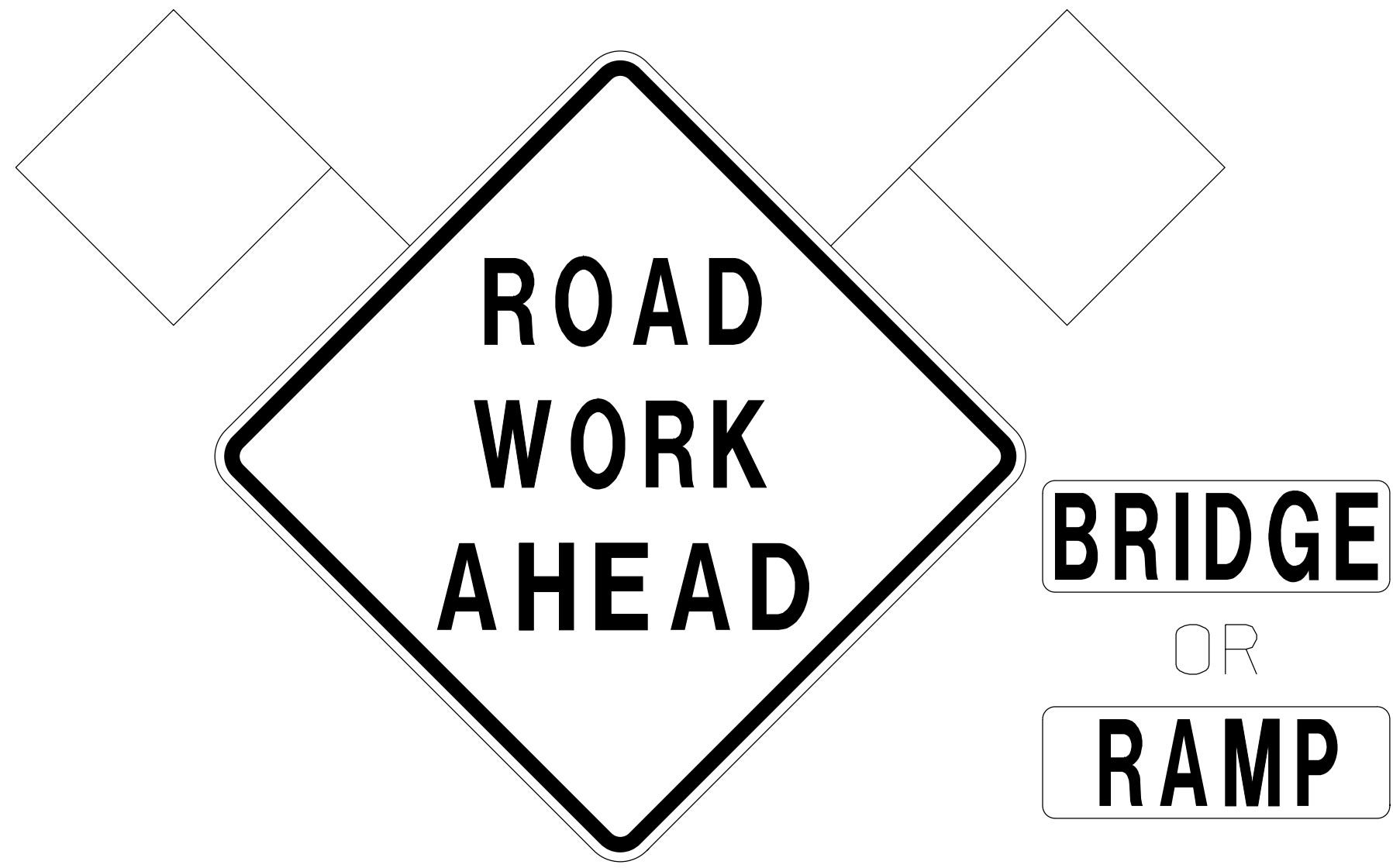

W020-1
2

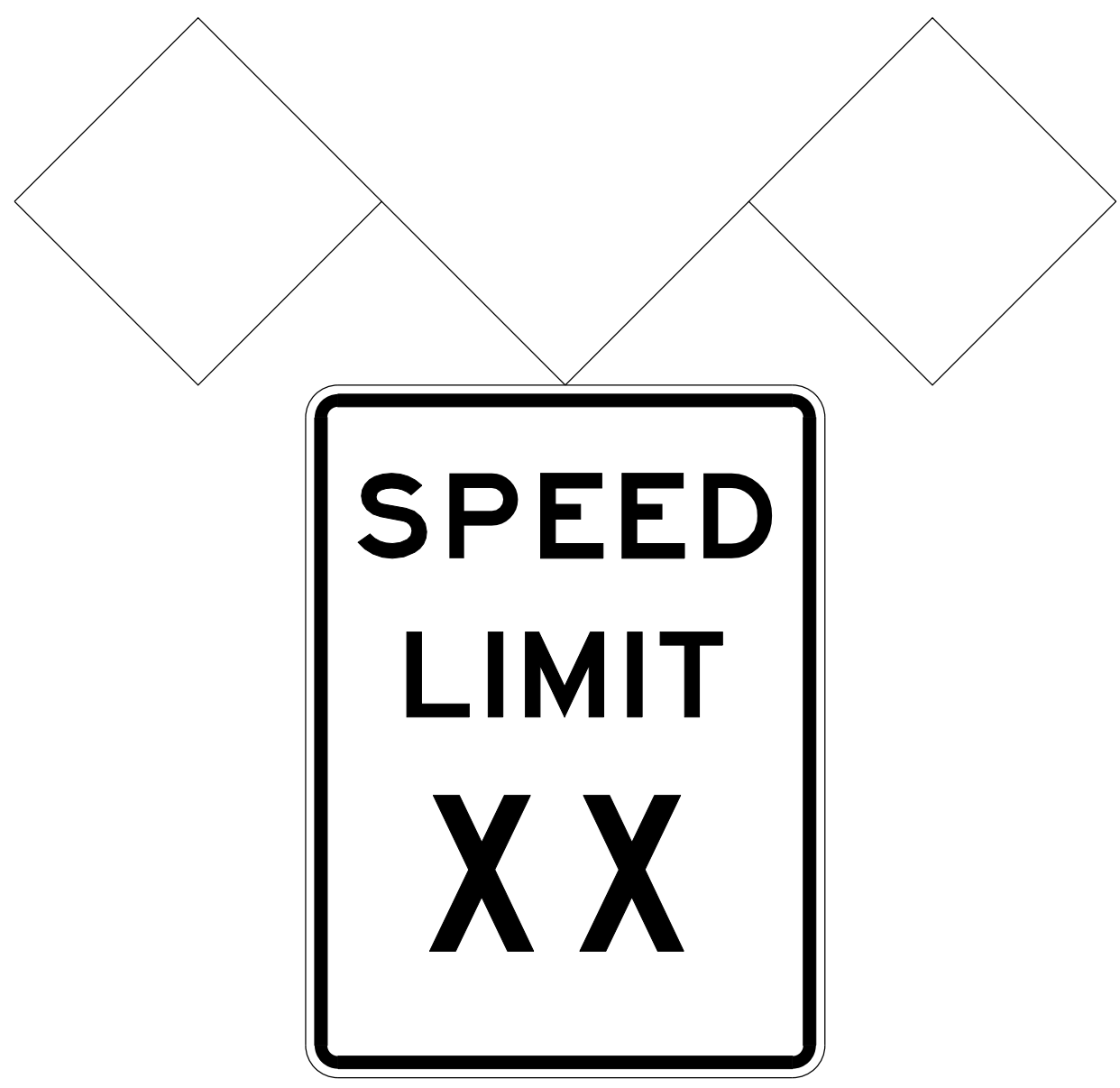

R2-1
4
"35" & "45"
25

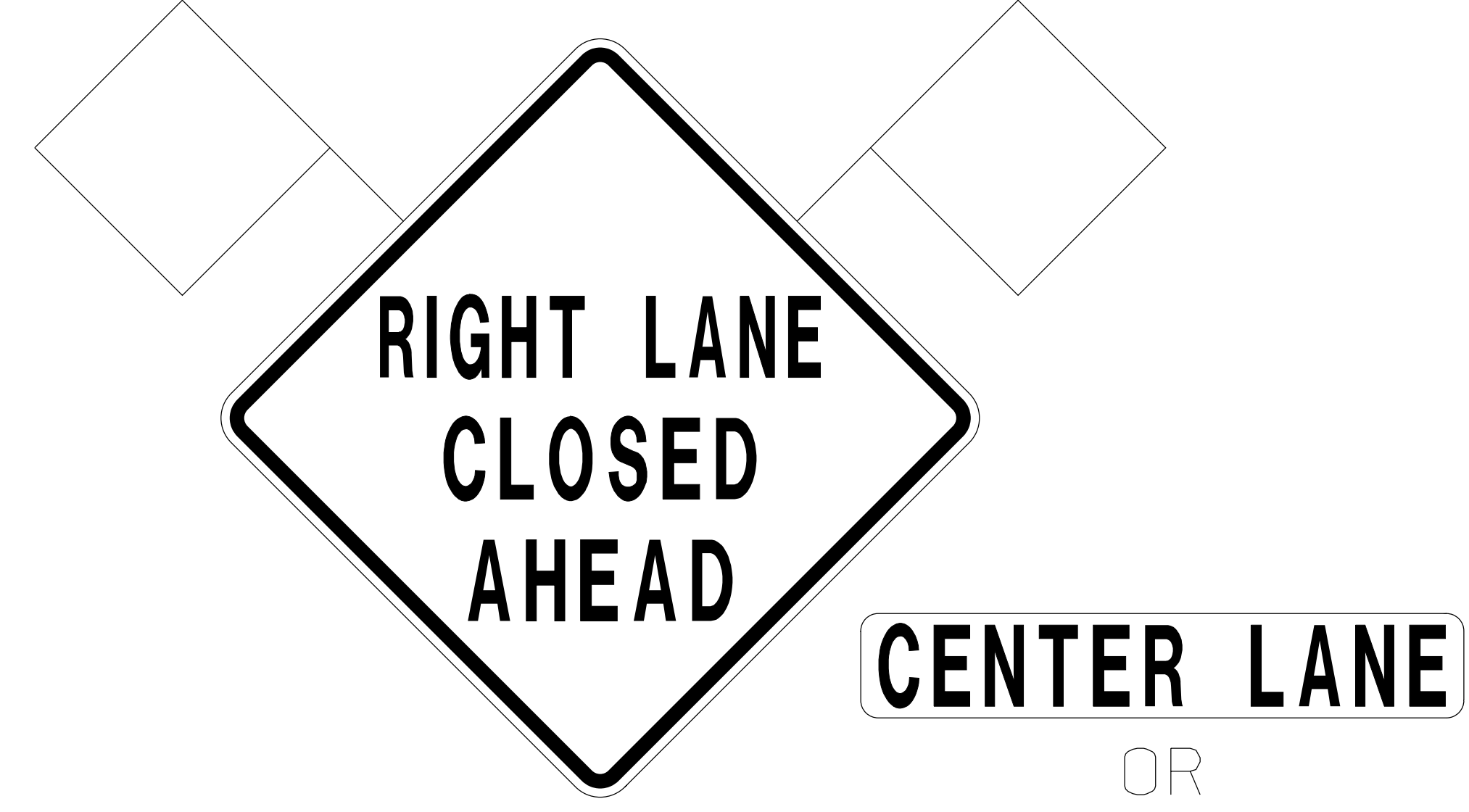

W020-5
5



W020-6a
6



W020-2
18



W020-3
20

NOTE:
FLAGS ARE NOT REQUIRED ON CITY STREETS

TEMPORARY TRAFFIC CONTROL
SHEET 2 OF 10
STREET SIGNS

"THIS MEDIA SHOULD NOT BE CONSIDERED A CERTIFIED DOCUMENT."

DATE PREPARED
1/7/2014

ROUTE I-670 STATE MO

DISTRICT KC SHEET NO. 14

COUNTY JACKSON

JOB NO. J412023

CONTRACT ID.

PROJECT NO.

BRIDGE NO. A08073

DATE	DESCRIPTION

MISSOURI HIGHWAYS AND TRANSPORTATION COMMISSION
MoDOT
105 WEST CAPITOL
JEFFERSON CITY, MO 65102
1-888-ASK-MODOT (1-888-273-6636)

TEMPORARY TRAFFIC CONTROL SHEET 3 OF 10 STREET SIGNS

IF A SEAL IS PRESENT ON THIS SHEET IT HAS BEEN ELECTRONICALLY SEALED AND DATED.



W020-3a

(20a)



R11-2

(29)

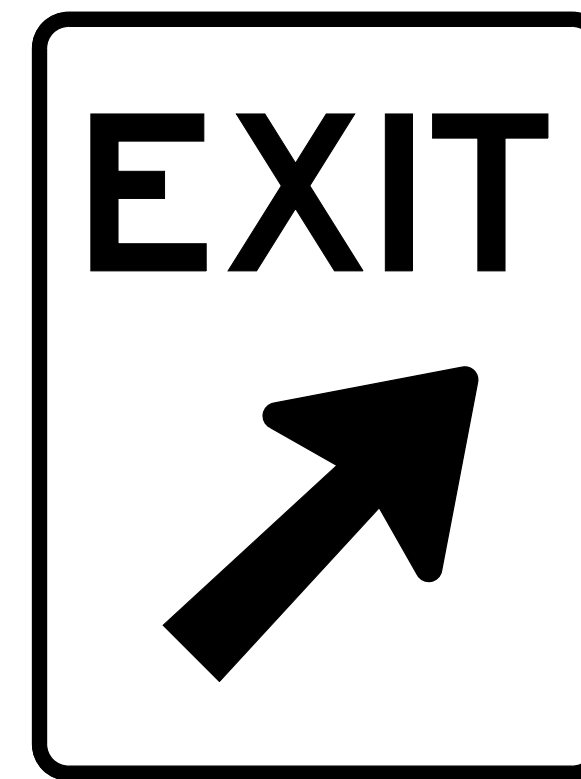

E05-1

(49)

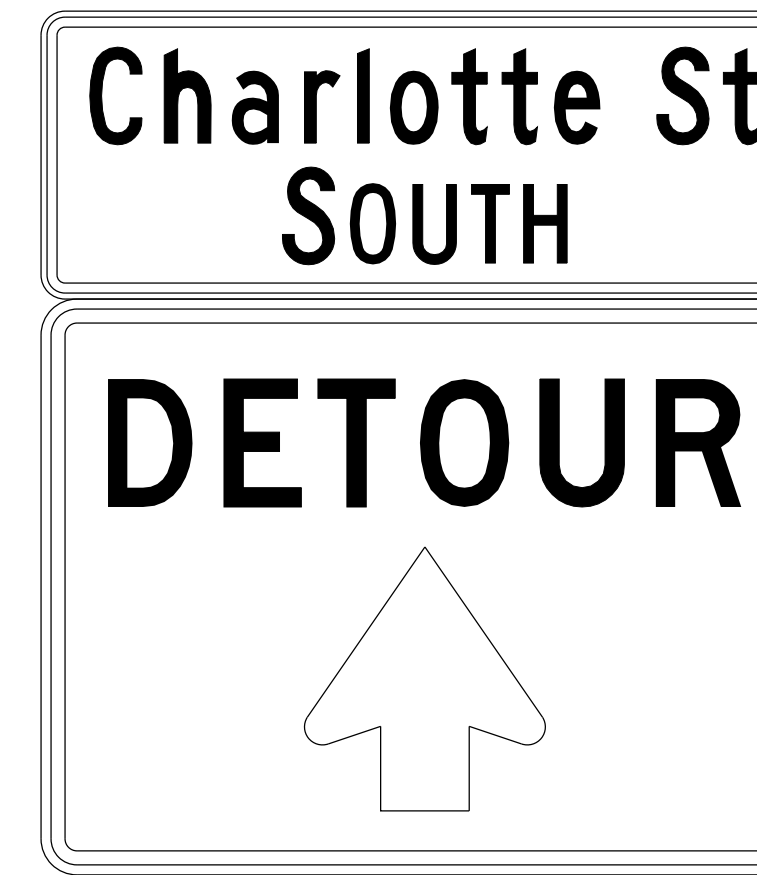

(50A)

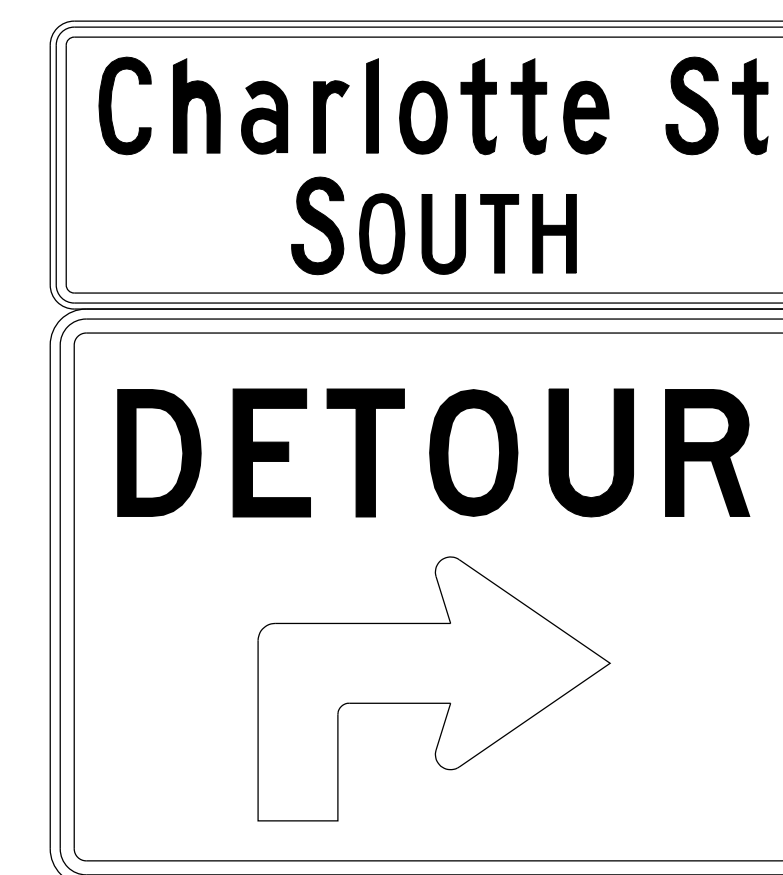

(50B)

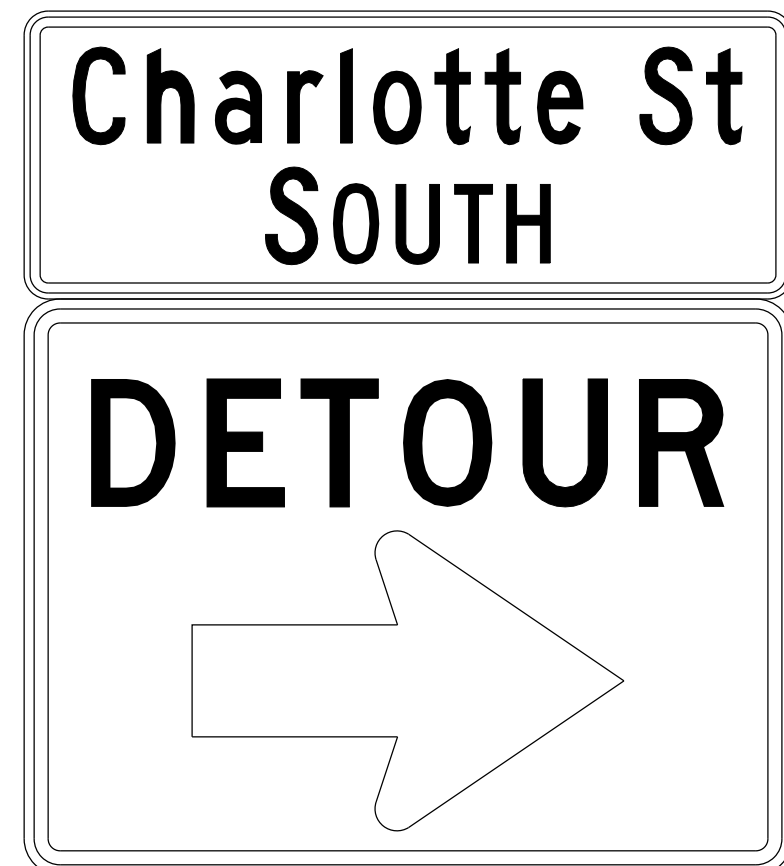

(50C)

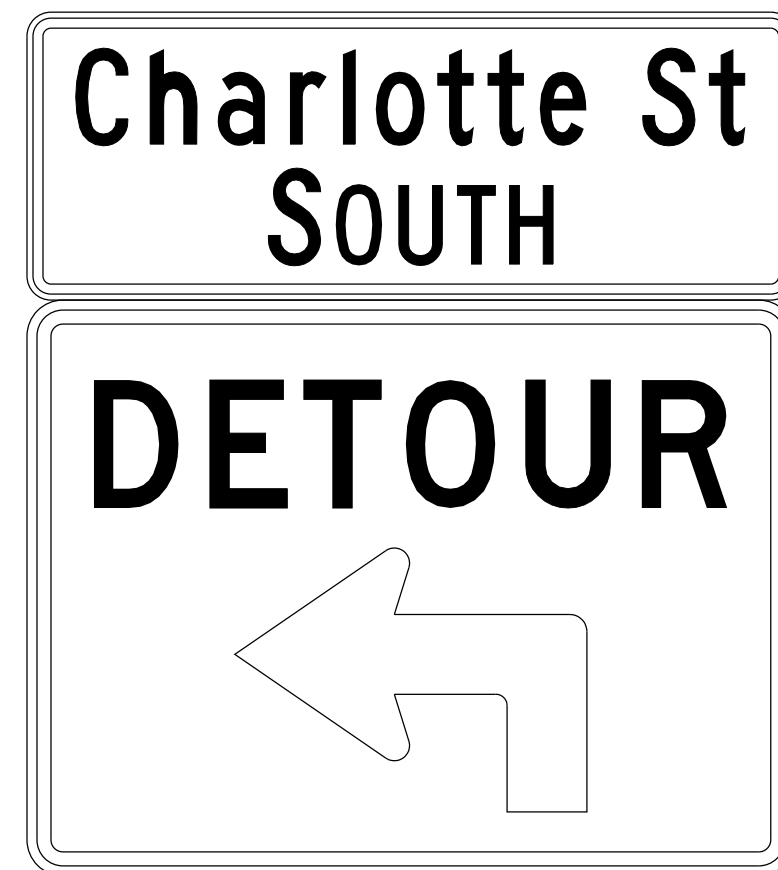

(50D)

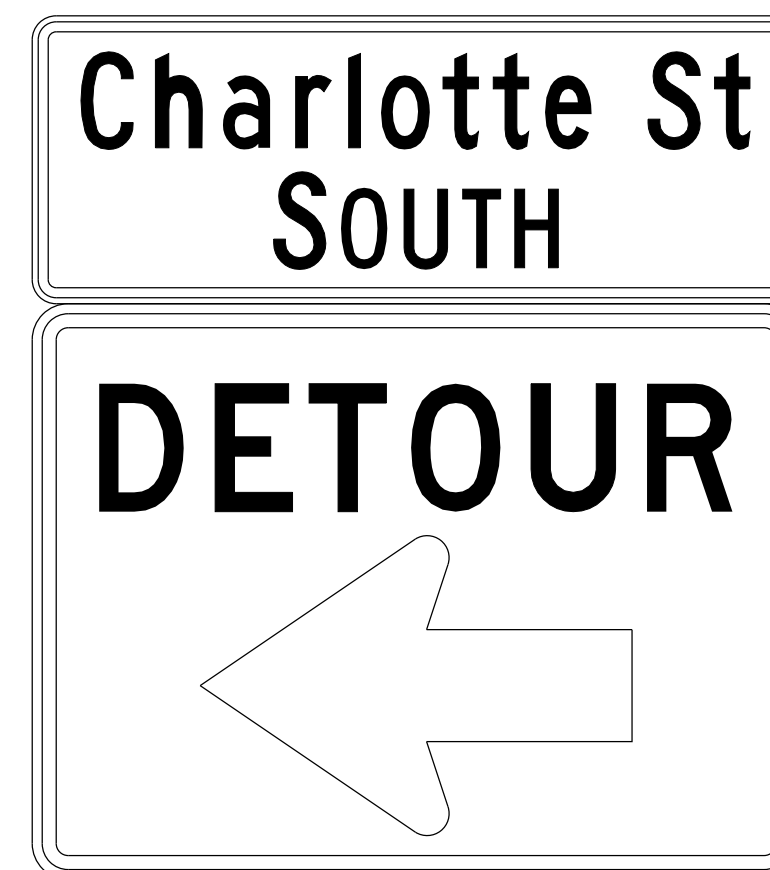

(50E)

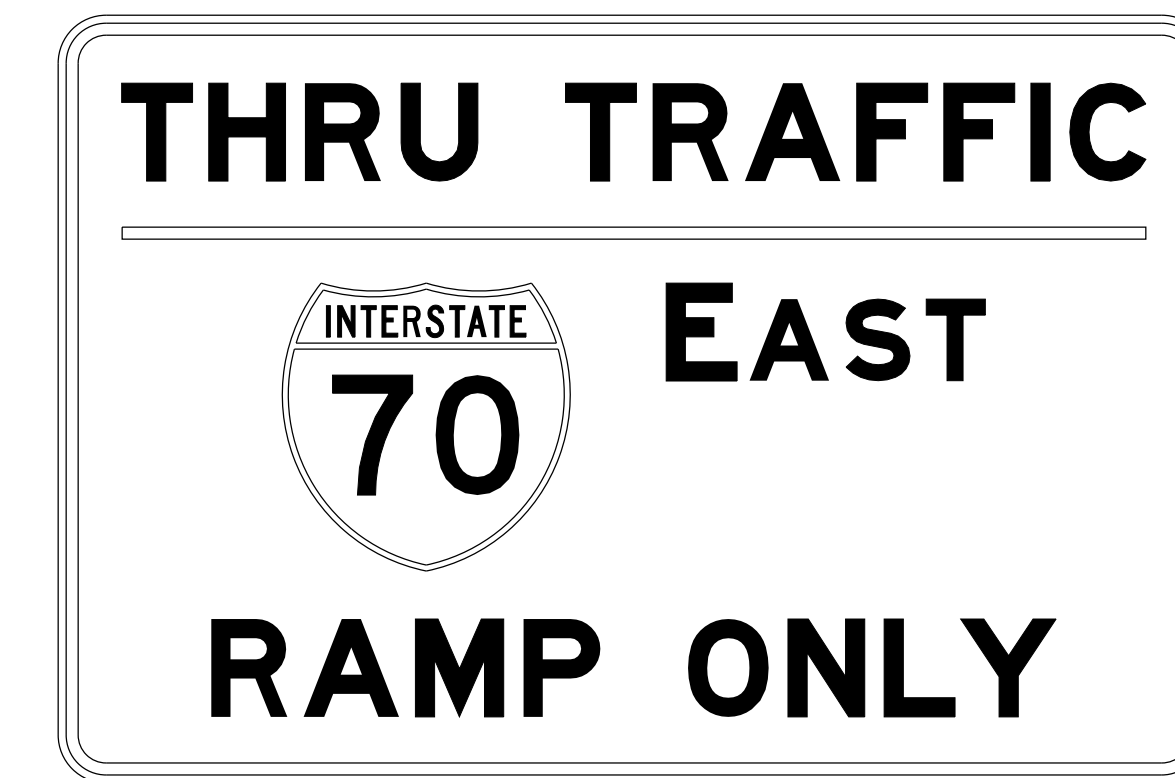

(50F)

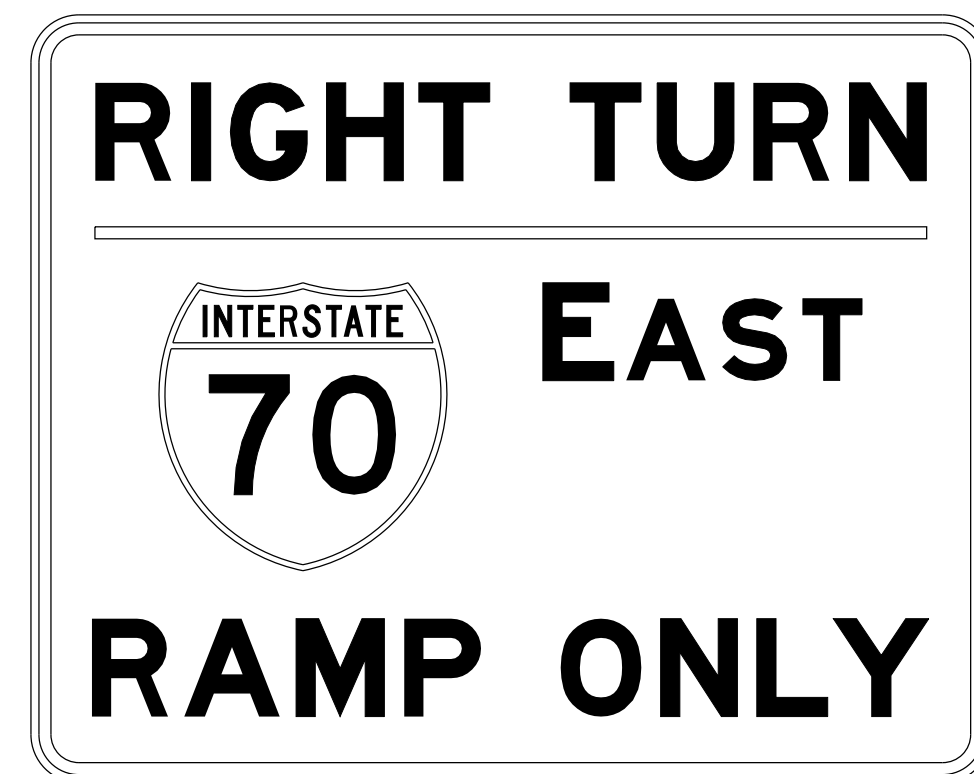

(50G)



M04-8a

(52)



G020-5aP

(54)

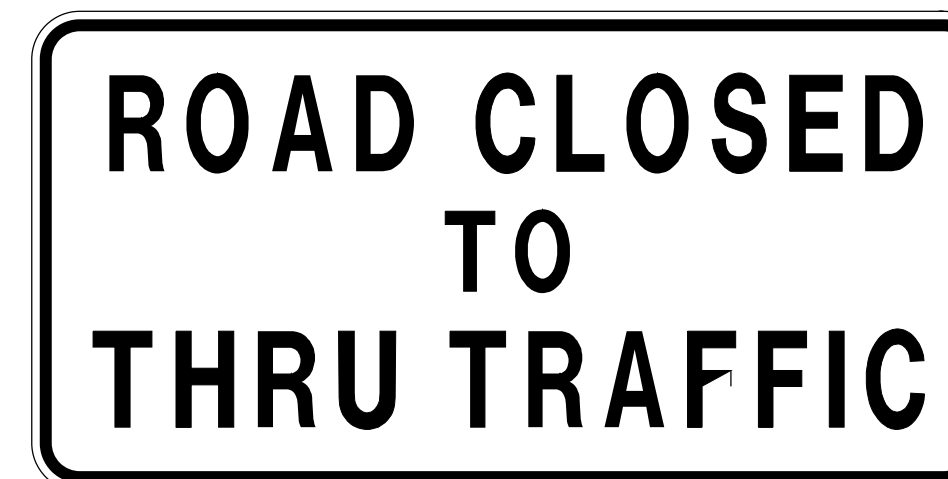

R11-4

(55)



R9-9

(60)



R9-11R

(61)

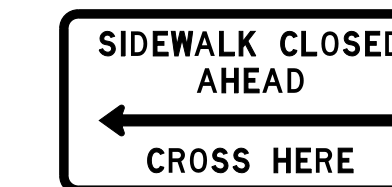

R9-11L

(62)

TEMPORARY TRAFFIC CONTROL SHEET 3 OF 10 STREET SIGNS

"THIS MEDIA SHOULD NOT BE CONSIDERED A CERTIFIED DOCUMENT."

DATE PREPARED
1/7/2014

ROUTE STATE
I-670 MO

DISTRICT SHEET NO.
KC 15

COUNTY
JACKSON

JOB NO.
J412023

CONTRACT ID.

PROJECT NO.

BRIDGE NO.
A08073

DATE	DESCRIPTION

MISSOURI HIGHWAYS AND TRANSPORTATION COMMISSION

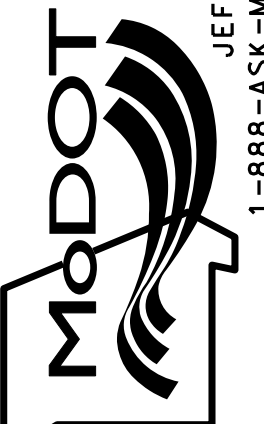

105 WEST CAPITOL
JEFFERSON CITY, MO 65102
1-888-ASK-MODOT (1-888-273-6636)

IF A SEAL IS PRESENT ON THIS SHEET IT HAS BEEN ELECTRONICALLY SEALED AND DATED.

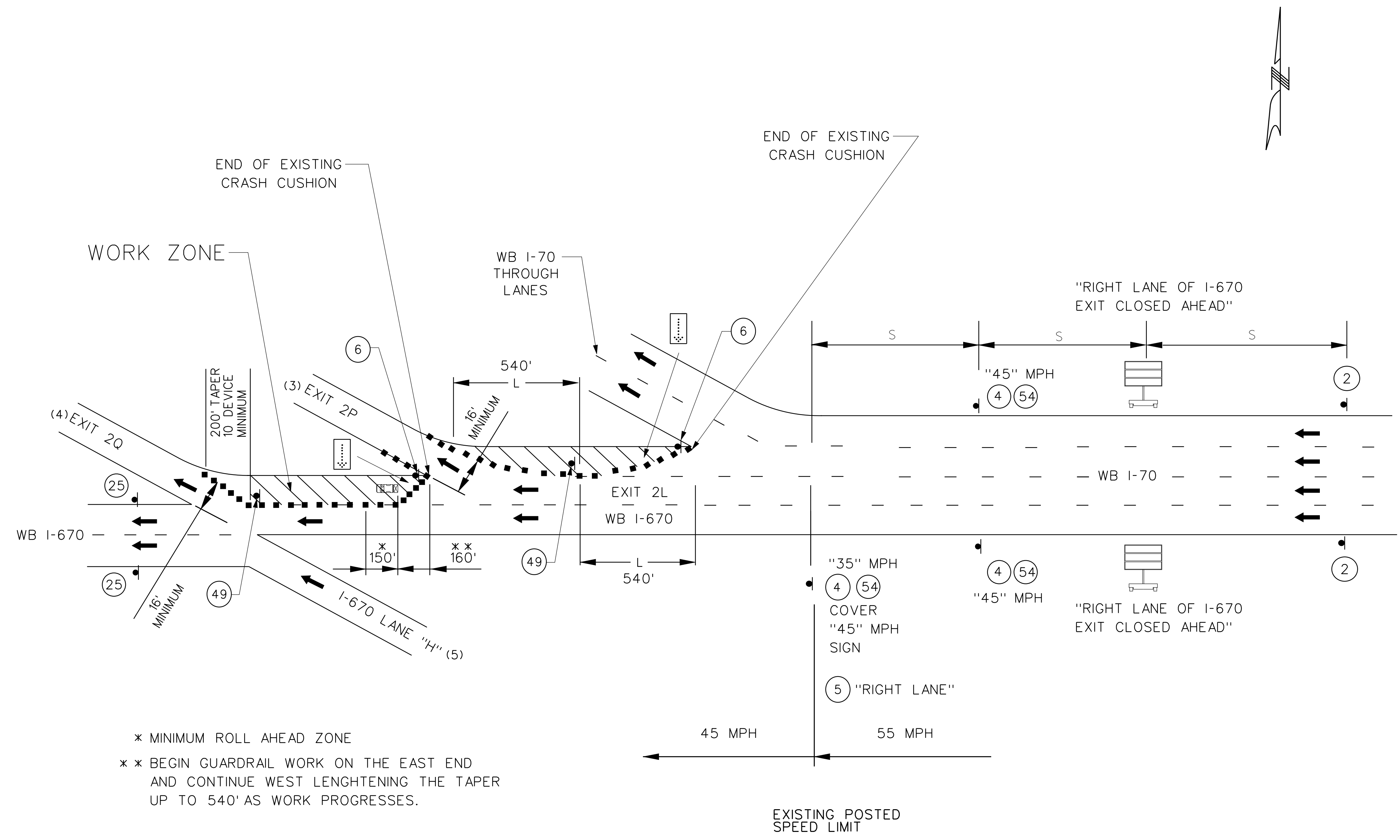

- * MINIMUM ROLL AHEAD ZONE
- ** BEGIN GUARDRAIL WORK ON THE EAST END AND CONTINUE WEST LENGTHENING THE TAPER UP TO 540' AS WORK PROGRESSES.

NOTES:

- (1) SEE TRAFFIC CONTROL SHEET 1 FOR SIGN AND CHANNELIZER SPACING.
- (2) WORK ZONES ARE FOR OVERNIGHT OR WEEKENDS ONLY. FOR WORK ZONES WHERE DEVICES ARE IN PLACE OVERNIGHT, USE TRIM-LINE CHANNELIZERS.
- (3) 13TH STREET RAMP.
- (4) LOCUST STREET & TRUMAN ROAD RAMP.
- (5) NORTHBOUND US 71 TO WESTBOUND I-670 RAMP.

TEMPORARY
TRAFFIC CONTROL
SHEET 4 OF 10
IS 670 GUARDRAIL
AND SLOPE PROTECTION

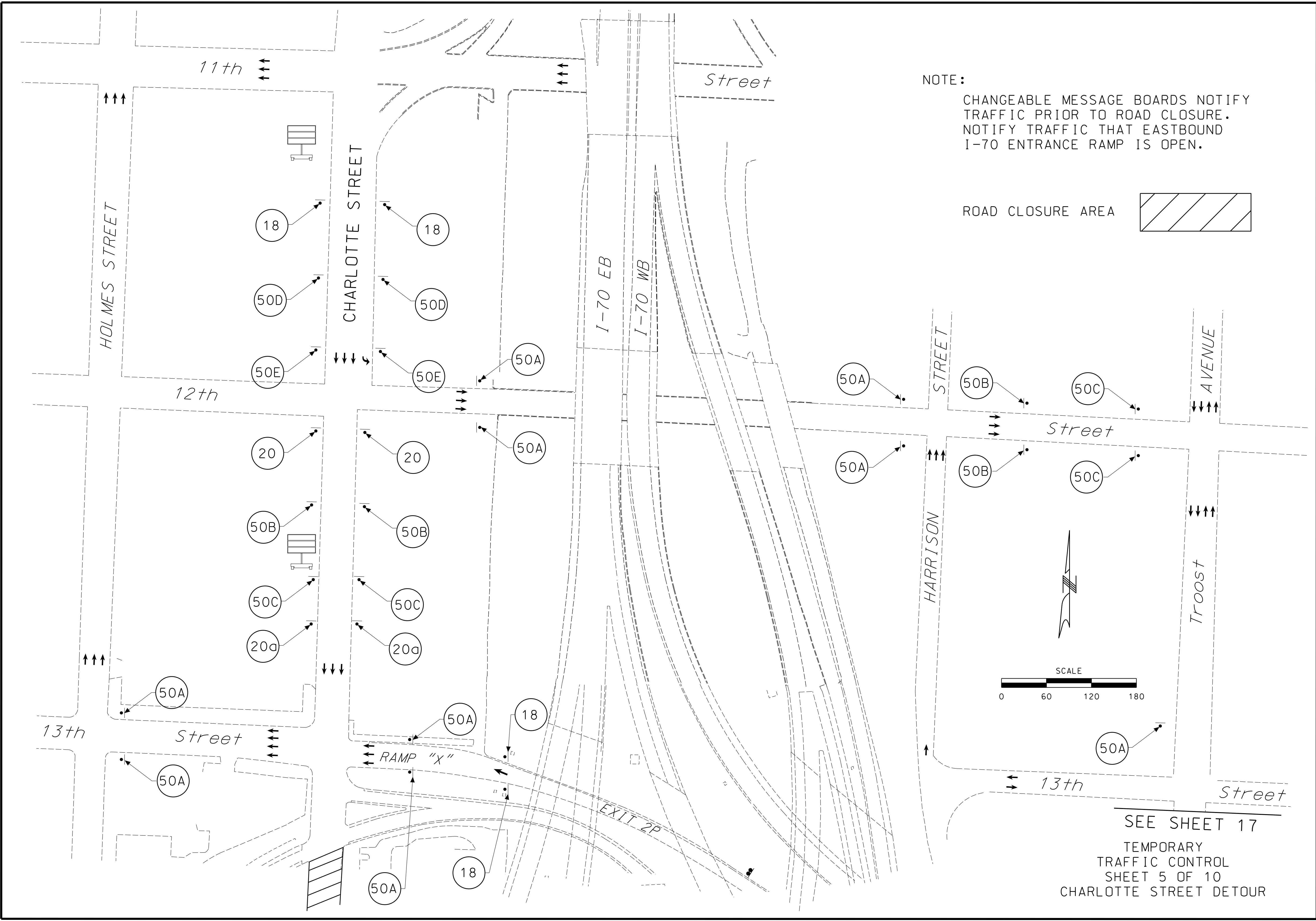

NOTE:

CHANGEABLE MESSAGE BOARDS NOTIFY TRAFFIC PRIOR TO ROAD CLOSURE. NOTIFY TRAFFIC THAT EASTBOUND I-70 ENTRANCE RAMP IS OPEN.

ROAD CLOSURE AREA 

SEE SHEET 17
 TEMPORARY
 TRAFFIC CONTROL
 SHEET 5 OF 10
 CHARLOTTE STREET DETOUR

"THIS MEDIA SHOULD NOT BE CONSIDERED A CERTIFIED DOCUMENT."

DATE PREPARED 1/7/2014	
ROUTE I-670	STATE MO
DISTRICT KC	SHEET NO. 16
COUNTY JACKSON	
JOB NO. J412023	
CONTRACT ID.	
PROJECT NO.	
BRIDGE NO. A08073	

DATE	DESCRIPTION

MISSOURI HIGHWAYS AND TRANSPORTATION COMMISSION



105 WEST CAPITOL
 JEFFERSON CITY, MO 65102
 1-888-ASK-MODOT (1-888-273-6636)

IF A SEAL IS PRESENT ON THIS SHEET IT HAS BEEN ELECTRONICALLY SEALED AND DATED.

SEE SHEET 16

"THIS MEDIA SHOULD NOT BE CONSIDERED A CERTIFIED DOCUMENT."

DATE PREPARED
1/7/2014

ROUTE I-670 STATE MO

DISTRICT KC SHEET NO. 17

COUNTY JACKSON

JOB NO. J412023

CONTRACT ID.

PROJECT NO.

BRIDGE NO. A08073

DATE	DESCRIPTION

DATE

MISSOURI HIGHWAYS AND TRANSPORTATION COMMISSION

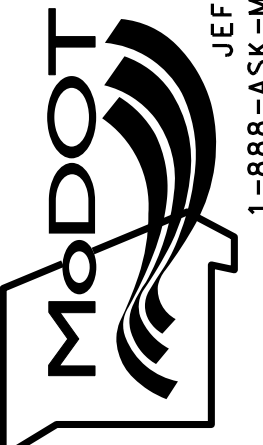

105 WEST CAPITOL
JEFFERSON CITY, MO 65102
1-888-ASK-MODOT (1-888-273-6636)

IF A SEAL IS PRESENT ON THIS SHEET IT HAS BEEN ELECTRONICALLY SEALED AND DATED.

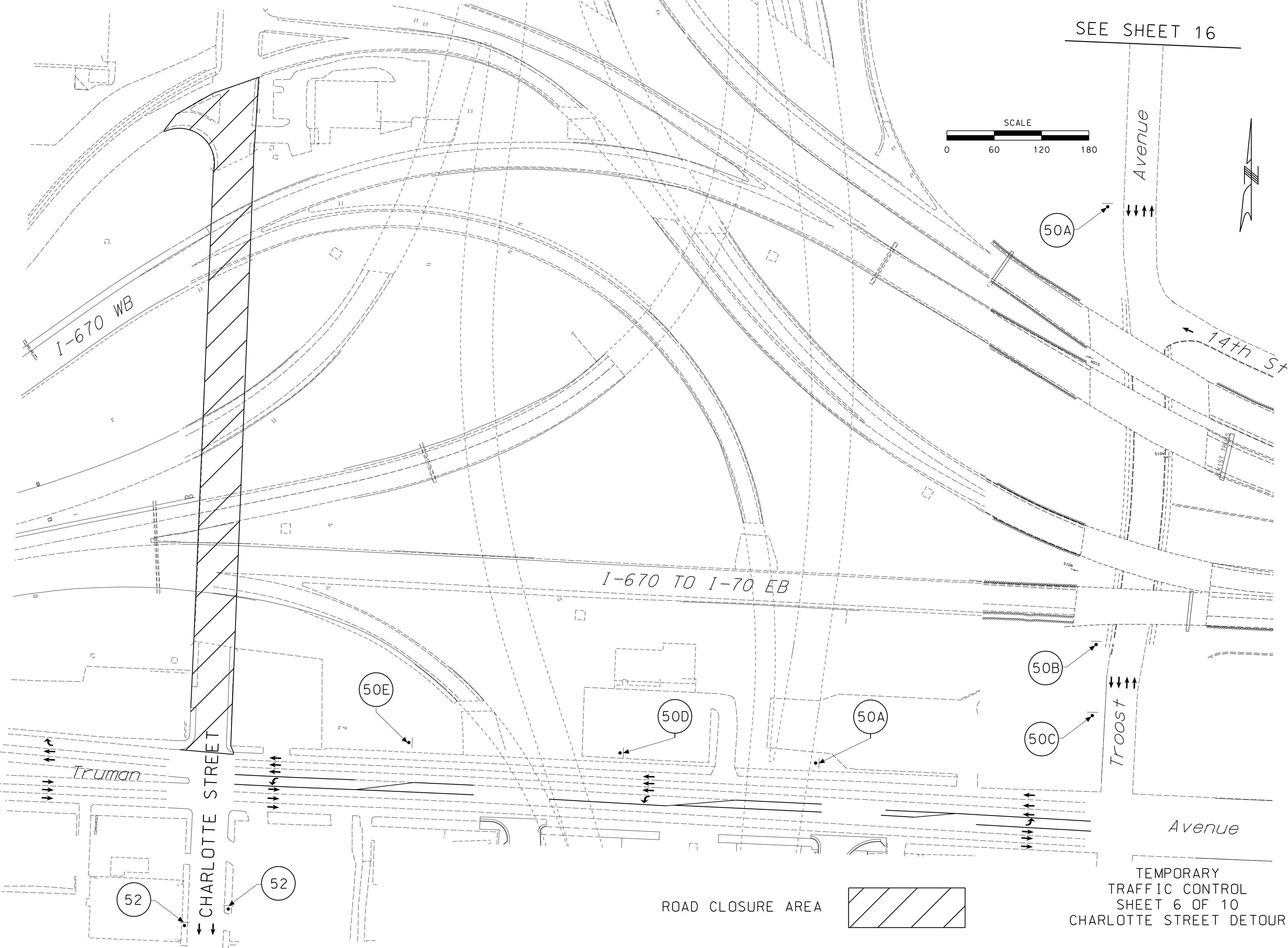
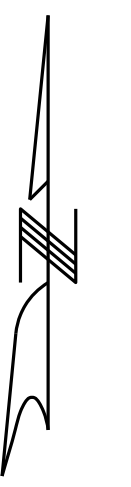
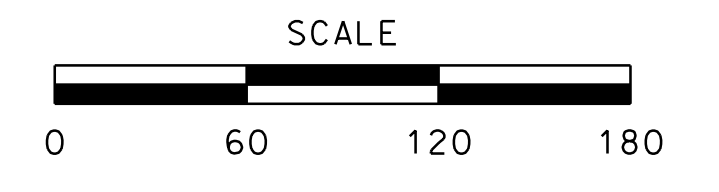

ROAD CLOSURE AREA

TEMPORARY TRAFFIC CONTROL SHEET 6 OF 10 CHARLOTTE STREET DETOUR

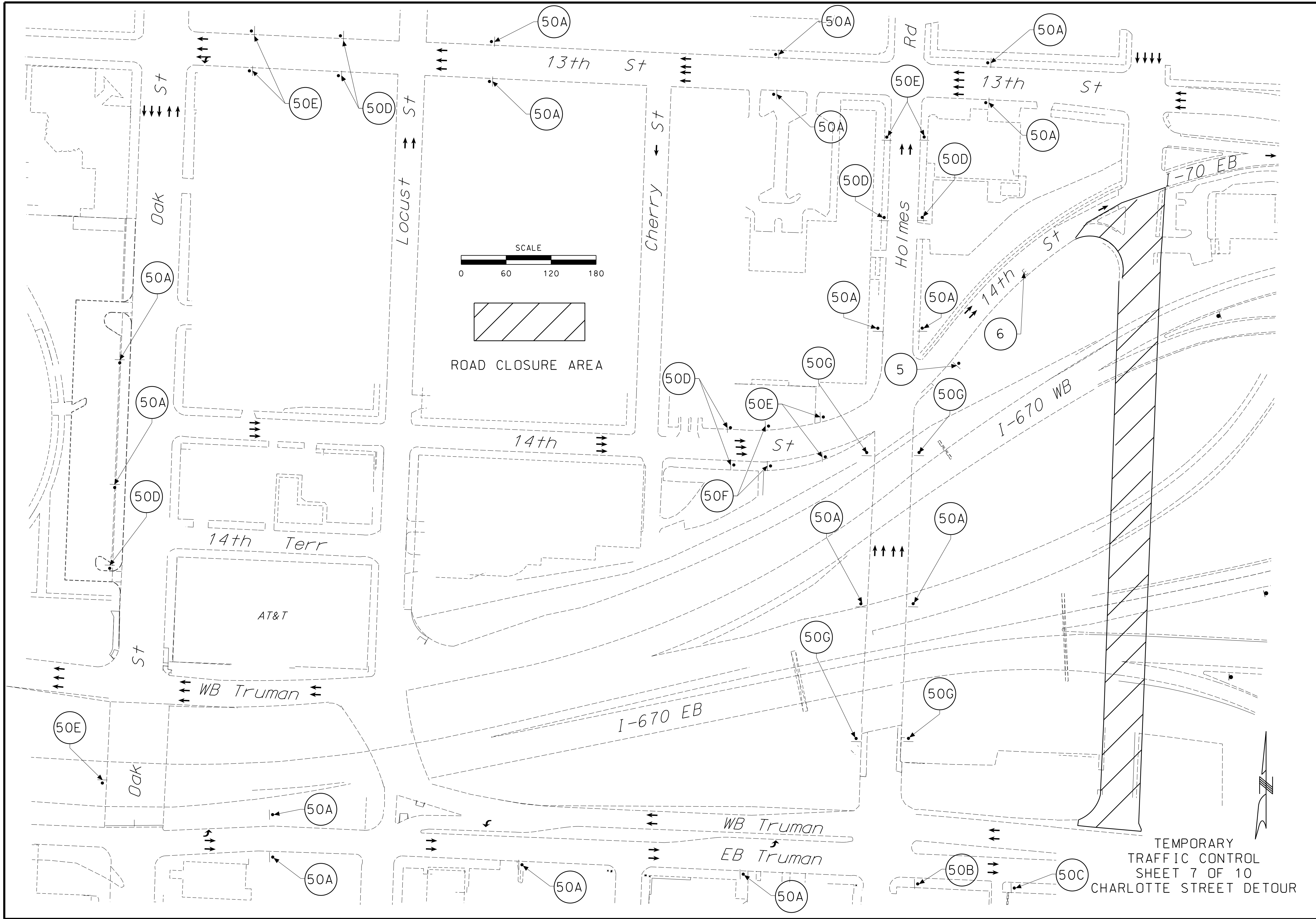

"THIS MEDIA SHOULD NOT BE CONSIDERED A CERTIFIED DOCUMENT."

DATE PREPARED
1/7/2014

ROUTE STATE

I-670 MO

DISTRICT SHEET NO.
KC 18

COUNTY

JACKSON

JOB NO.

J412023

CONTRACT ID.

PROJECT NO.

BRIDGE NO.
A08073

DATE	DESCRIPTION

MISSOURI HIGHWAYS AND TRANSPORTATION COMMISSION

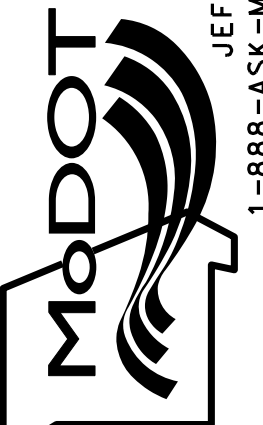

105 WEST CAPITOL
JEFFERSON CITY, MO 65102
1-888-ASK-MODOT (1-888-273-6636)

TEMPORARY
TRAFFIC CONTROL
SHEET 7 OF 10
CHARLOTTE STREET DETOUR

IF A SEAL IS PRESENT ON THIS SHEET IT HAS BEEN ELECTRONICALLY SEALED AND DATED.

NOTE:

SIDEWALK CONSTRUCTION SHALL BE COMPLETED ON ONE SIDE (EAST OR WEST) OF CHARLOTTE STREET PRIOR TO CONSTRUCTION BEGINNING ON THE OTHER SIDE.
PLACE SIGNS 60, 61 AND 62 BASED ON SIDE OF CHARLOTTE STREET SIDEWALKS ARE BEING CONSTRUCTED.

- (1) DURING EAST SIDE OF CHARLOTTE STREET SIDEWALKS CONSTRUCTION.
- (2) DURING WEST SIDE OF CHARLOTTE STREET SIDEWALKS CONSTRUCTION.
- (3) PLACE AT 12TH STREET DURING EAST SIDE OF CHARLOTTE STREET SIDEWALKS CONSTRUCTION.
- (4) PLACE AT 12TH STREET DURING WEST SIDE OF CHARLOTTE STREET SIDEWALKS CONSTRUCTION.
- (5) PLACE AT HOLMES ROAD DURING WEST SIDE OF CHARLOTTE STREET SIDEWALKS CONSTRUCTION.

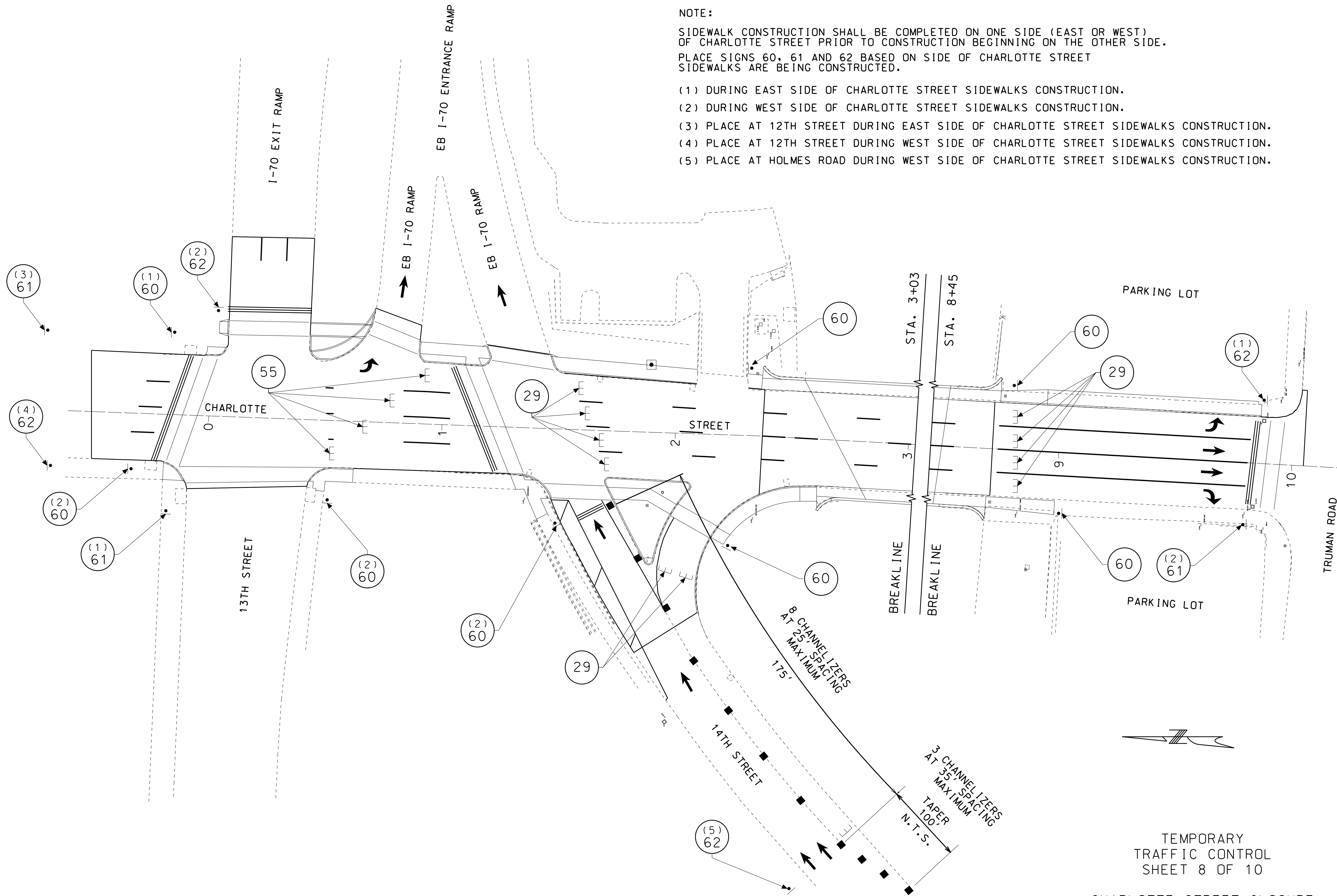

TEMPORARY
TRAFFIC CONTROL
SHEET 8 OF 10
CHARLOTTE STREET CLOSURE

"THIS MEDIA SHOULD
NOT BE CONSIDERED
A CERTIFIED
DOCUMENT."

DATE PREPARED	
1/7/2014	
ROUTE	STATE
I-670	MO
DISTRICT	SHEET NO.
KC	19
COUNTY	
JACKSON	
JOB NO.	
J412023	
CONTRACT ID.	

PROJECT NO.	
BRIDGE NO.	
A08073	

DATE	DESCRIPTION

MISSOURI HIGHWAYS AND TRANSPORTATION
COMMISSION

105 WEST CAPITOL
JEFFERSON CITY, MO 65102
1-888-ASK-MODOT (1-888-275-6636)

IF A SEAL IS PRESENT ON THIS SHEET IT HAS BEEN ELECTRONICALLY SEALED AND DATED.

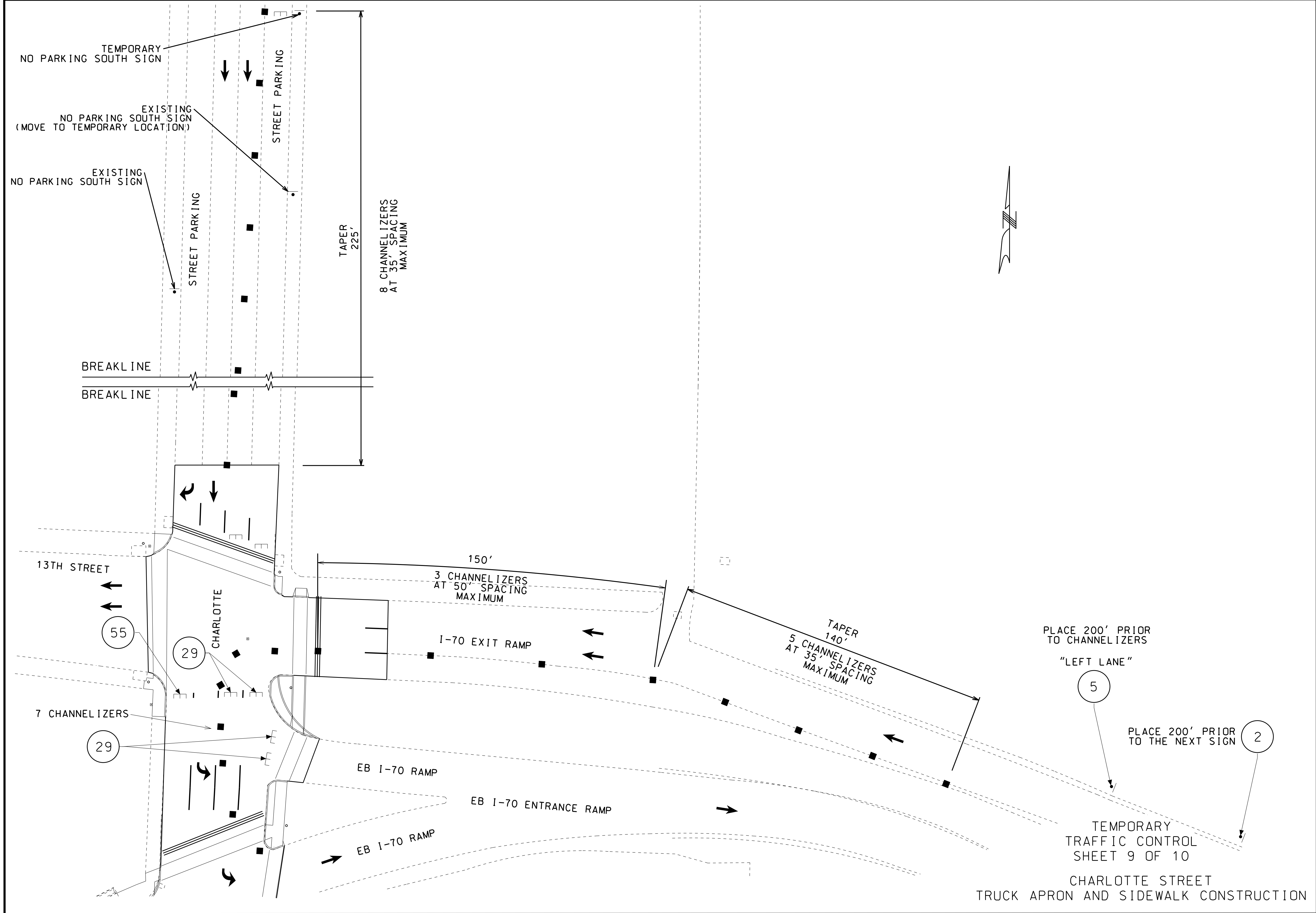

"THIS MEDIA SHOULD NOT BE CONSIDERED A CERTIFIED DOCUMENT."

DATE PREPARED	
1/7/2014	
ROUTE	STATE
I-670	MO
DISTRICT	SHEET NO.
KC	20
COUNTY	
JACKSON	
JOB NO.	
J412023	
CONTRACT ID.	
PROJECT NO.	
BRIDGE NO.	
A08073	

DESCRIPTION	DATE

MISSOURI HIGHWAYS AND TRANSPORTATION COMMISSION



105 WEST CAPITOL JEFFERSON CITY, MO 65102
1-888-ASK-MODOT (1-888-275-6636)

IF A SEAL IS PRESENT ON THIS SHEET IT HAS BEEN ELECTRONICALLY SEALED AND DATED.

SIGN NO.	50A
STATION	
ROADWAY	VARIOUS

SIGN NO.	50B
STATION	
ROADWAY	VARIOUS

SIGN NO.	50C
STATION	
ROADWAY	VARIOUS

SIGN NO.	50D
STATION	
ROADWAY	VARIOUS

SIGN NO.	50E
STATION	
ROADWAY	VARIOUS

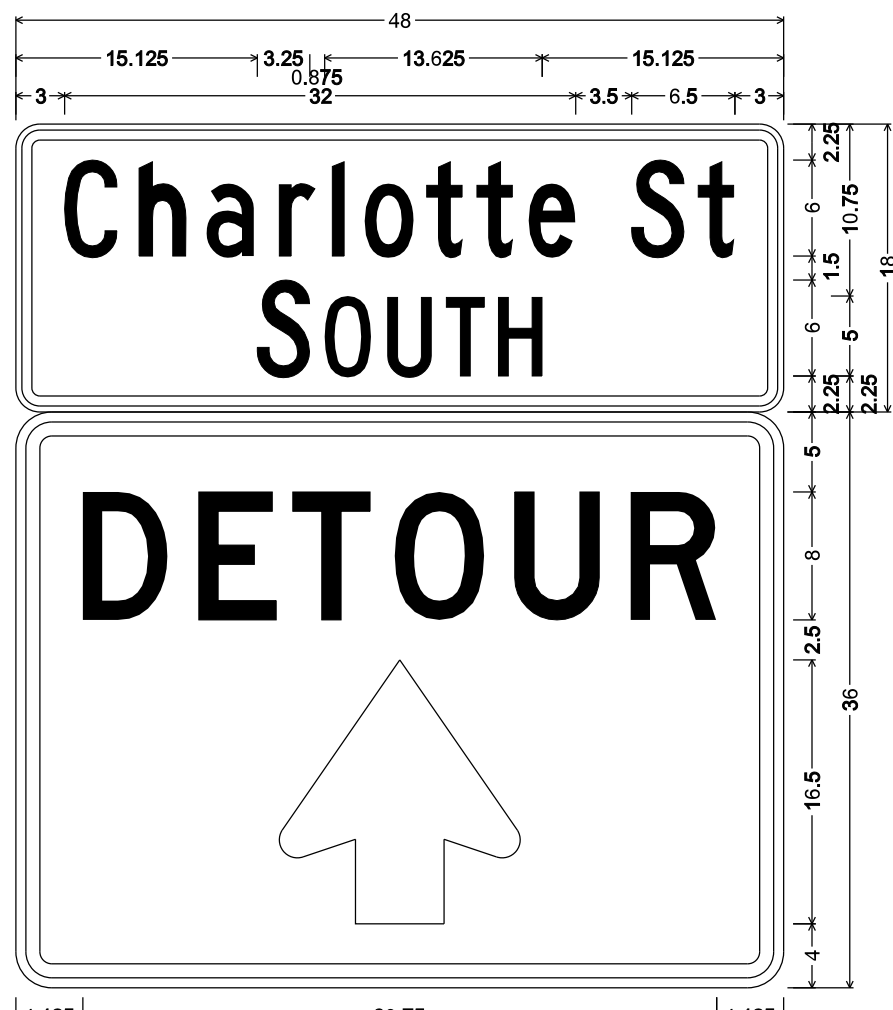

Street Name Plaque SHR4L1:
1.500" Radius, 0.625" Border, 0.375" Indent, Black on Orange;
[Charlotte St] C 85% spacing; [SOUTH] C;
MO4-9-48 SHR4L1:
2.250" Radius, 0.875" Border, 0.625" Indent, Black on Orange;
[DETOUR] D;
Table of letter and object lefts.

C	h	a	r	o	u	t	s	o
3,000	7,750	11,875	16,500	19,625	21,750	25,625	28,875	32,000
S	T							
38,500	42,625							

S	O	U	T	H
15,125	19,250	23,250	26,875	30,125

D	E	U	R
4,125	11,375	17,250	23,625

⊕	16,500
---	--------

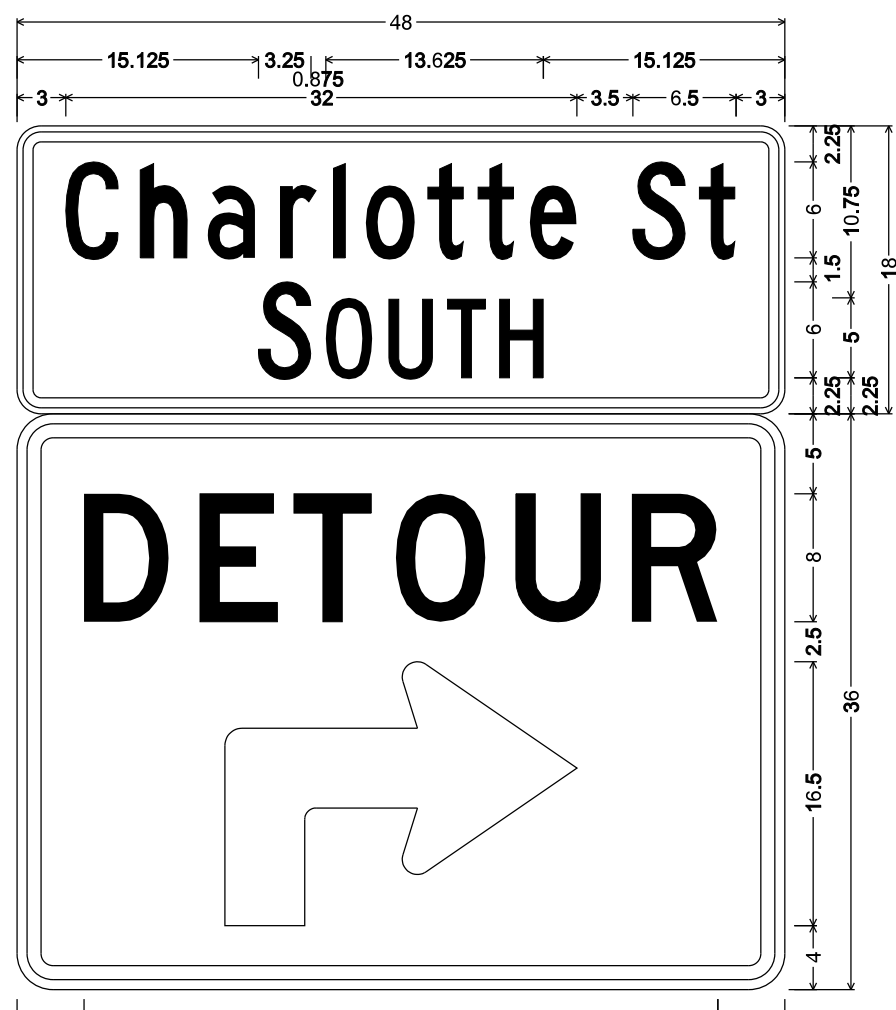

Street Name Plaque SHR4L1:
1.500" Radius, 0.625" Border, 0.375" Indent, Black on Orange;
[Charlotte St] C 85% spacing; [SOUTH] C;
MO4-9-48 SHR4L1:
2.250" Radius, 0.875" Border, 0.625" Indent, Black on Orange;
[DETOUR] D;
Table of letter and object lefts.

C	h	a	r	o	u	t	s	o
3,000	7,750	11,875	16,500	19,625	21,750	25,625	28,875	32,000
S	T							
38,500	42,625							

S	O	U	T	H
15,125	19,250	23,250	26,875	30,125

D	E	U	R
4,125	11,375	17,250	23,625

⊕	13,000
---	--------

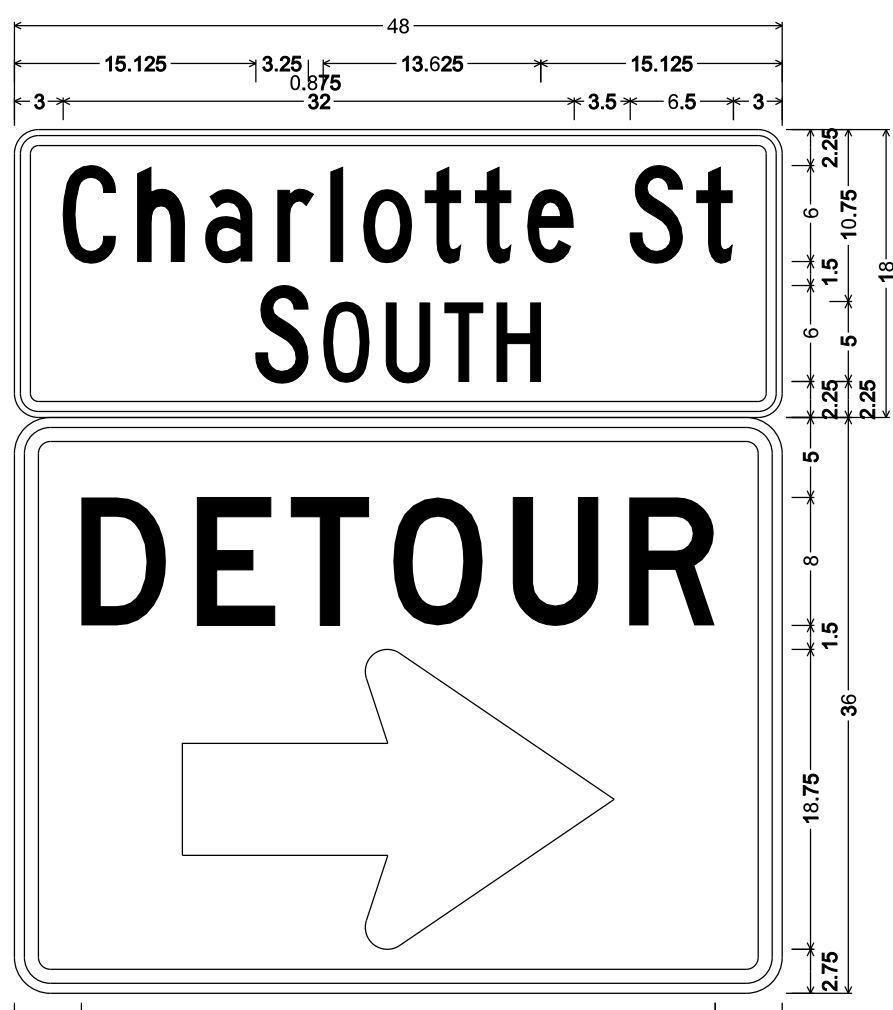

Street Name Plaque SHR4L1:
1.500" Radius, 0.625" Border, 0.375" Indent, Black on Orange;
[Charlotte St] C 85% spacing; [SOUTH] C;
MO4-9-48 SHR4L1:
2.250" Radius, 0.875" Border, 0.625" Indent, Black on Orange;
[DETOUR] D; Standard Arrow Custom 27.000" X 18.750" 0";
Table of letter and object lefts.

C	h	a	r	o	u	t	s	o
3,000	7,750	11,875	16,500	19,625	21,750	25,625	28,875	32,000
S	T							
38,500	42,625							

S	O	U	T	H
15,125	19,250	23,250	26,875	30,125

D	E	U	R
4,125	11,375	17,250	23,625

⊕	10,500
---	--------

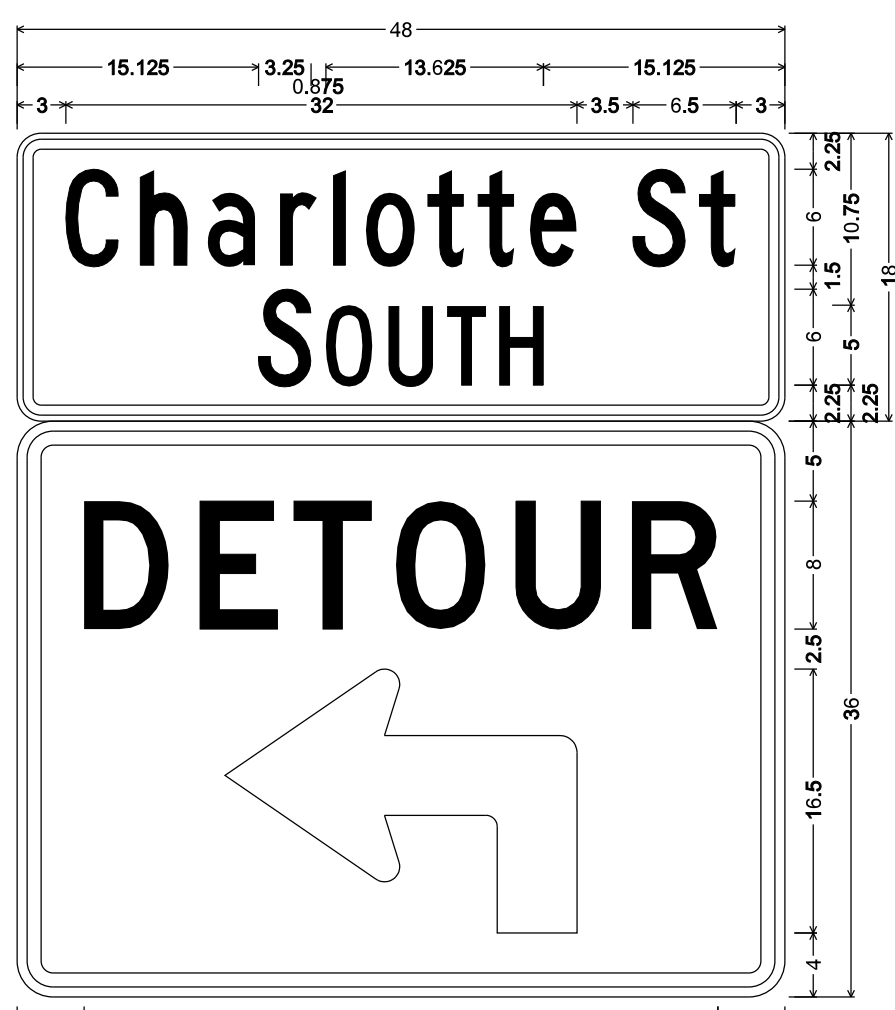

Street Name Plaque SHR4L1:
1.500" Radius, 0.625" Border, 0.375" Indent, Black on Orange;
[Charlotte St] C 85% spacing; [SOUTH] C;
MO4-9-48 SHR4L1:
2.250" Radius, 0.875" Border, 0.625" Indent, Black on Orange;
[DETOUR] D;
Table of letter and object lefts.

C	h	a	r	o	u	t	s	o
3,000	7,750	11,875	16,500	19,625	21,750	25,625	28,875	32,000
S	T							
38,500	42,625							

S	O	U	T	H
15,125	19,250	23,250	26,875	30,125

D	E	U	R
4,125	11,375	17,250	23,625

⊕	13,000
---	--------

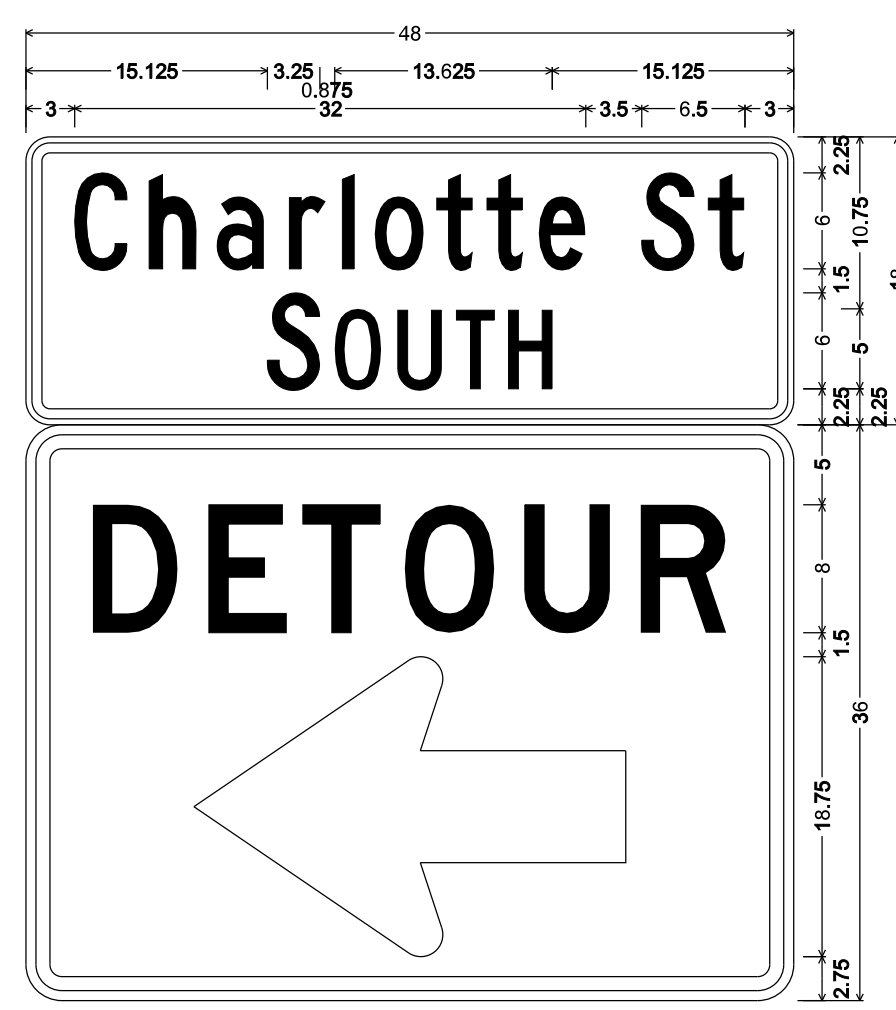

Street Name Plaque SHR4L1:
1.500" Radius, 0.625" Border, 0.375" Indent, Black on Orange;
[Charlotte St] C 85% spacing; [SOUTH] C;
MO4-9-48 SHR4L1:
2.250" Radius, 0.875" Border, 0.625" Indent, Black on Orange;
[DETOUR] D; Standard Arrow Custom 27.000" X 18.750" 180";
Table of letter and object lefts.

C	h	a	r	o	u	t	s	o
3,000	7,750	11,875	16,500	19,625	21,750	25,625	28,875	32,000
S	T							
38,500	42,625							

S	O	U	T	H
15,125	19,250	23,250	26,875	30,125

D	E	U	R
4,125	11,375	17,250	23,625

⊕	10,500
---	--------

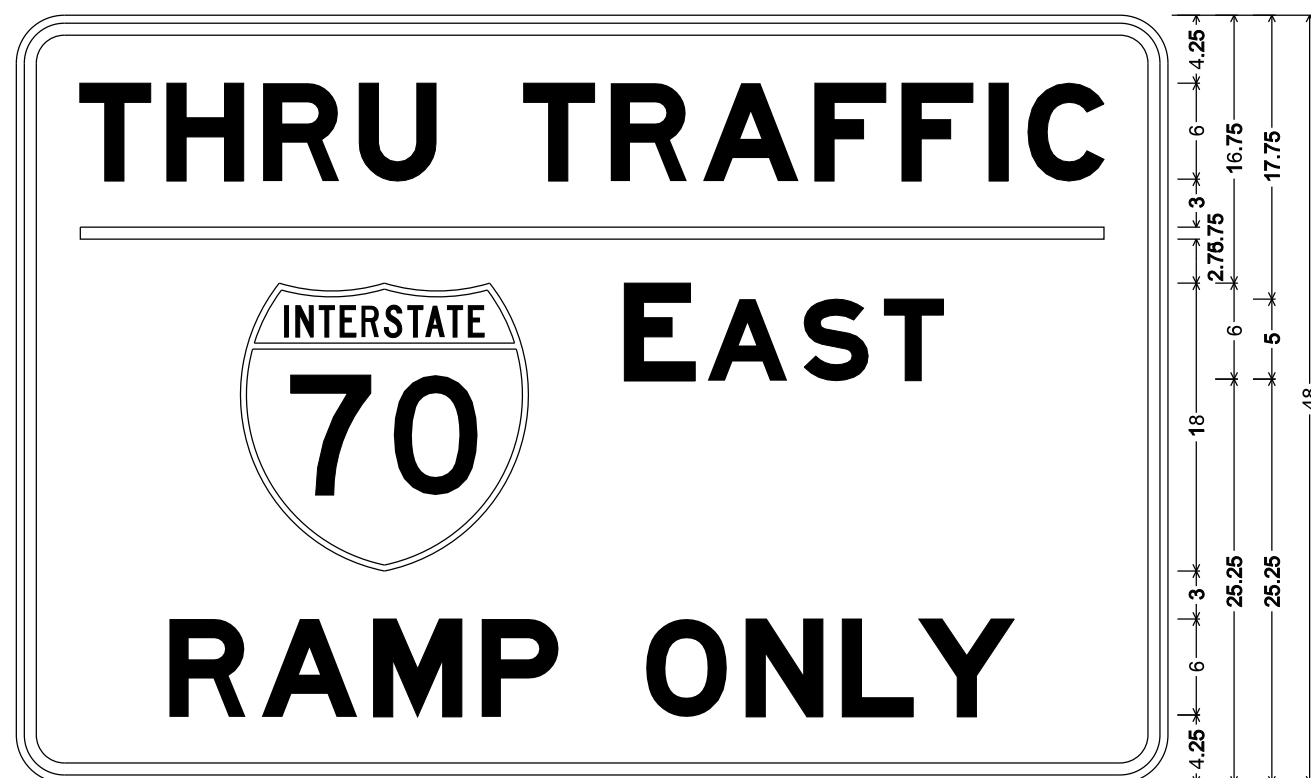

SPECIAL SHR4L1: 3.000" Radius, 0.750" Border, 0.500" Indent, Black on Orange;
[THRU TRAFFIC] E Mod 80% spacing; [EAST] E Mod; [RAMP ONLY] E Mod 80% spacing;
Table of letter and object lefts.

T	H	R	U	T	R	A	F	F	I	C
4,000	9,375	15,375	21,500	31,750	37,125	42,875	49,875	55,375	60,875	63,250

⊕	4,000
---	-------

E	A	S	T
14,000	38,000	43,250	48,250

R	A	M	P	O	N	L	Y
9,625	15,375	22,375	29,125	39,375	45,625	51,625	56,375

SIGN NO.	50F
STATION	
ROADWAY	14TH ST.

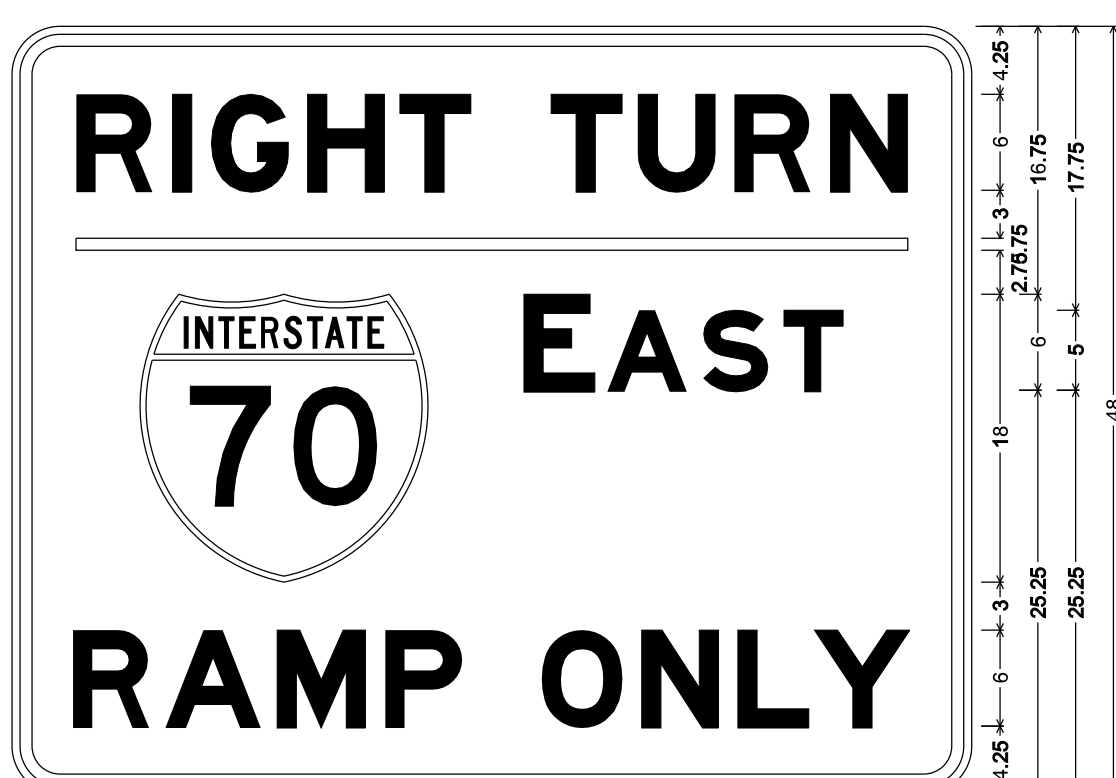

SPECIAL SHR4L1: 3.000" Radius, 0.750" Border, 0.500" Indent, Black on Orange;
[RIGHT TURN] E Mod 80% spacing; [EAST] E Mod; [RAMP ONLY] E Mod 80% spacing;
Table of letter and object lefts.

R	I	G	H	T	T	U	R	N
4,000	10,000	12,500	18,500	24,250	33,750	39,125	45,125	51,125

⊕	4,000
---	-------

E	A	S	T
9,000	32,000	37,250	43,250

R	A	M	P	O	N	L	Y
3,875	9,625	16,625	23,375	33,125	39,375	45,375	50,125

SIGN NO.	50G
STATION	
ROADWAY	HOLMES ST.

"THIS MEDIA SHOULD NOT BE CONSIDERED A CERTIFIED DOCUMENT."

DATE PREPARED	1/7/2014
ROUTE	I-670
STATE	MO
DISTRICT	KC
SHEET NO.	21
COUNTY	JACKSON
JOB NO.	J412023
CONTRACT ID.	
PROJECT NO.	
BRIDGE NO.	A08073

DESCRIPTION	
DATE	

MISSOURI HIGHWAYS AND TRANSPORTATION COMMISSION

105 WEST CAPITOL JEFFERSON CITY, MO 65102
1-888-ASK-MODOT (1-888-273-6636)

TEMPORARY TRAFFIC CONTROL SHEET 10 OF 10
SPECIAL SIGNS DETAIL SHEET

IF A SEAL IS PRESENT ON THIS SHEET IT HAS BEEN ELECTRONICALLY SEALED AND DATED.

POST NUMBER	PULL BOX NUMBER	LOCATION	BASE										PULL BOX				POST																																													
			APPROACH	STATION	OFFSET	A					F					C	CONCRETE** (CU. YDS.)	PREFORMED		CONCRETE		DRAIN TYPE*	PED. PUSH BUTTON POST	TYPE C & CL								TYPE B & BL								LUMINAIRE BRACKET ARM*																						
						CLASS 1	CLASS 2	CLASS 3	CLASS 5	STANDARD	DOUBLE, TYPE A	DOUBLE, TYPE B	ARM LENGTH	SIGNAL SPACING				ARM LENGTH	LEFT ARM E					RIGHT ARM K				INCLUDED ANGLE	4 FT.	6 FT.	8 FT.	10 FT.	12 FT.	15 FT.																												
														CLASS 4	A				B	C	D			D'	B	C	D								D'	E	K	E	K	E	K	F	G	H	H'	F	G	H	H'	L	M	N	N'	L	M	N	N'					
9		CHARLOTTE	AT 13TH STREET																																								CONTROLLER (AS REQ'D)																			
10		SOUTHEAST	QUADRANT																																																											
11		NORTHEAST	QUADRANT																																																											
12		NORTHWEST	QUADRANT																																																											
13		SOUTH	OF SOUTHEAST QUADRANT																																																											
13		CHARLOTTE	AT 14TH STREET																																																											
14		SOUTHEAST	QUADRANT																																																											
15		NORTHEAST	QUADRANT																																																											
16		NORTHWEST	QUADRANT																																																											
17		NORTHWEST	QUADRANT																																																											
18		SOUTHWEST	QUADRANT																																																											
SUBTOTAL																																																														
TOTAL				4.40																						1	9																																			

THIS MEDIA SHOULD NOT BE CONSIDERED A CERTIFIED DOCUMENT.

DATE PREPARED
1/7/2014

ROUTE
I-670

STATE
MO

DISTRICT
KC

SHEET NO.
22

COUNTY
JACKSON

JOB NO.
J412023

CONTRACT ID.

PROJECT NO.

BRIDGE NO.
A08073

SPAN NUMBER	POST NUMBER	FACE NUMBER	LUMINAIRE 150W SODIUM	INDICATIONS *												VISORS *		LOUVERS *					BACKPLATE*		BRACKET*		ONE-FACE SECTION				TWO-FACE SECTIONS																																	
				12" LENS CONVENTIONAL						12" LENS OPTICAL LIMITING						12" LENS	PED.	A	B	C	D	E	F	1	II	III	1-	3-	4-	5-	11-	33-	34-	35-	44-	45-																												
				R	Y	YL	YR	FY	LFY	G	S	L	R	+	R	R	Y	YL	YR	FY	LFY	G	S	L	R	A	B	C	D	E	F	1	2	3	4	5	I	II	III	T	S	C	B	T	S	C	B	T	S	C	B	T	S	B	T	S	C	B	S	B	S	B	S	B
SUBTOTAL																																																																
TOTAL																																																																

SIGNS				
QUANTITY	MUTCD SIGN NUMBER	SIZE (INCHES)	AREA (SQ. FT.)	TOTAL AREA EACH SIGN (SQ. FT.)
	R10-10L	24 X 30	5.0	
	R10-10R	24 X 30	5.0	
	R3-5L	30 X 36	7.5	
	R3-5R	30 X 36	7.5	
	R3-5S	30 X 36	7.5	
	R3-6L	30 X 36	7.5	
	R3-6R	30 X 36	7.5	
	R3-2	24 X 24	4.0	
	R3-1	24 X 24	4.0	
	R3-3	24 X 24	4.0	
	R10-5	24 X 30	5.0	
	R10-12	24 X 30	5.0	
	D3-16***	VAR. X 16		
	D3-18***	VAR. X 18		
7	R10-3bR	9 X 12	0.75	5.25
6	R10-3bL	9 X 12	0.75	4.50
	R10-11A	24 X 30	5.0	
TOTAL AREA ITEM NO. 903-50.68				10

SUBTOTAL OPTICALLY LIMITED	
SUBTOTAL CONVENTIONAL	
SUBTOTAL COMBINATION OL & CONV	
TOTAL OPTICALLY LIMITED	
TOTAL CONVENTIONAL	
TOTAL COMBINATION OL & CONV	

SPAN WIRE POLES		
POST NUMBER	WOOD CLASS IV	STEEL (A10 BASE REQUIRED)
SUBTOTAL		
TOTAL		

SPAN WIRE CABLE SPANS				
SPAN NUMBER	FROM POST	TO POST	SINGLE MESSENGER ASSEMBLY (LIN. FT.)	MESSENGER ASSEMBLY WITH TETHER (LIN. FT.)
SUBTOTAL				
TOTAL				

REMARKS

ALL LENGTHS AND SPACINGS ARE IN FEET UNLESS OTHERWISE INDICATED.

* ITEMS FOR WHICH SEPARATE PAYMENT WILL NOT BE MADE.

** SEE STANDARD PLANS 902.10 AND 902.30 FOR CONCRETE REQUIREMENTS ON BASES.

*** USE D3-16 FOR ONE LINE. USE D3-18 FOR TWO LINE.

SIGNAL STRUCTURES WHICH WILL EXCEED THE DIMENSION LIMITS SHOWN ON STANDARD PLAN SHEETS IN SECTION 902 AND ANY OTHER INSTALLATION WHERE THE DETAILS OF CONSTRUCTION ARE NOT FURNISHED IN THE CONTRACT PLANS, SHALL BE DESIGNED BY A PROFESSIONAL ENGINEER IN ACCORDANCE WITH THE 2001 AASHTO STANDARD SPECIFICATIONS FOR STRUCTURAL SUPPORTS FOR HIGHWAY SIGNS, LUMINAIRES AND TRAFFIC SIGNALS, 4TH EDITION, AND LATEST INTERIMS. THE STRUCTURE SHALL BE DESIGNED AS IMPORTANCE CATEGORY I FOR FATIGUE WITH A 50-YEAR DESIGN LIFE. THE CONTRACTOR SHALL SUBMIT A SET OF SHOP DETAIL DRAWINGS INCLUDING WELD PROCEDURE SPECIFICATIONS AND DESIGN COMPUTATIONS FOR MODOT RECORDS AND REFERENCE. THE SUBMITTED DRAWINGS AND CALCULATIONS SHALL BE SIGNED AND SEALED IN ACCORDANCE WITH THE LAWS RELATING TO ARCHITECTS AND PROFESSIONAL ENGINEERS (CHAPTER 327, RSMO.), AND SHALL INCLUDE A TITLE BLOCK OR SUMMARY SHEET WHICH LISTS AND CERTIFIES THAT THE PRODUCT MEETS ALL OF THE SPECIFIED DESIGN CRITERIA.

LEGEND

T - TOP MOUNT
 S - SIDE MOUNT
 C - SPANWIRE MOUNT
 B - MAST ARM MOUNT

CHARLOTTE STREET AT 13TH & 14TH STREETS
 INTERSECTION

SIGNALS SHEET
 SHEET 1 OF 7

DESCRIPTION

DATE	DESCRIPTION

MISSOURI HIGHWAYS AND TRANSPORTATION COMMISSION

105 WEST CAPITOL
 JEFFERSON CITY, MO 65102
 1-888-ASK-MODOT (1-888-275-6636)

D-37A

POWER SUPPLY														
LOCATION			POWER SUPPLY ASSEMBLY		CIRCUIT BREAKER TRIP RATING*				LIGHTING CONTROL * (ON POWER SUPPLY)		SERVICE POLE			
APPROACH	STATION	OFFSET	DRAWING 902.15	DRAWING	CONTROLLER		POWER SUPPLY DISCONNECT		120 VOLT CONTROL CABINET		MAIN BREAKER	CONTRACT FURNISH		UTILITY COMPANY
					AUXILIARY BREAKER	CONT & SIGNAL LAMPS	MAIN BREAKER	SIGNALS LIGHTING						
			Type		15 Amps		Amps		Amps		Amps	Ci.	Ft.	
			Type		15 Amps		Amps		Amps		Amps	Ci.	Ft.	

CONTROLLER ASSEMBLY AND AUXILIARY EQUIPMENT																										
LOCATION			SYSTEM MASTER (CLOSED LOOP)		ACTUATED		ON-OFF* SWITCH		COORDINATION INTERFACE *					NEMA CABINET TYPE *			170 CABINET TYPE *		170 SOFTWARE *							
APPROACH	STATION	OFFSET	NEMA		170		TYPE		12C/7C HARDWARE (1)		TIME BASE	CLOSED LOOP		FIBER	TIME * CLOCK	E			332		336S		BITRAN		WAPITI	
							I	II	MASTER	LOCAL		NEMA	170													

DETECTOR SCHEDULE						
DETECTOR NUMBER	APPROACH	TYPE				
		PUSH BUTTON (EACH)	INDUCTION LOOP (2)			VIDEO
			STANDARD (EACH)	DELAY/EXTEND *	CALL UNIT *	
	SB CHARLOTTE AT 13TH		4			
	WB I-670 RAMP AT 13TH		3			
** 8B, 4A	WB I-670 RAMP X	2				
6A, 2A	SB CHARLOTTE STREET	2				
4B, 8A	WB 13TH STREET	1				
4C, 8C	NORTH. EB I-70 RAMP Y	2				
	EB 14TH AT CHARLOTTE		1			
8E, 4D	SOUTH. EB I-70 RAMP Y	2				
6B, 2B	SB CHARLOTTE STREET	2				
4E, 8D	EB 14TH STREET	2				
TOTAL		7 RT. & 6 LT.	8			

* ITEMS FOR WHICH SEPARATE PAYMENT WILL NOT BE MADE.
 ** PUSH BUTTON EXTENSION AT NO DIRECT PAY.

- (1) MoDOT "D" PLUG SHALL BE WIRED INTO ALL NEMA CONTROLLERS WITH 7C HARDWARE INTERCONNECT.
- (2) USE EXISTING.
- (3) FOR WHEELCHAIR ACCESSIBILITY INSTALL AS NEEDED EXTENSION TO MAKE PUSH BUTTON FLUSH WITH CURB AT NO DIRECT PAY.

170 OUTPUT FILE ASSIGNMENTS							
FR1							MONITOR
FR2							
FR3							
FR4							

170 AUXILIARY OUTPUT FILE							
FR5							X
FR6							

NEMA DETECTOR ASSIGNMENT								
CARD POSITION								
	1	2	3	4	5	6	7	8
CHANNEL	1							
	2							

TOTAL NUMBER OF DETECTOR CARDS(2-CHANNEL) = (2)

170 INPUT FILE ASSIGNMENTS														
CHANNEL	1	2	3	4	5	6	7	8	9	10	11	12	13	14
"I"	U													
	L													
"J"	U													
	L													

TOTAL NUMBER OF DETECTOR CARDS(2-CHANNEL) = (2)

NEMA LOAD SWITCH ASSIGNMENTS											
1	2	3	4	5	6	7	8	9	10	11	12

CHARLOTTE STREET AT 13TH & 14TH STREETS
 INTERSECTION

SIGNALS SHEET
 SHEET 3 OF 7

"THIS MEDIA SHOULD NOT BE CONSIDERED A CERTIFIED DOCUMENT."

DATE PREPARED
 1/7/2014
 ROUTE STATE
 I-670 MO
 DISTRICT SHEET NO.
 KC 24
 COUNTY
 JACKSON
 JOB NO.
 J412023
 CONTRACT ID.
 PROJECT NO.
 BRIDGE NO.
 A08073

DATE	DESCRIPTION

MISSOURI HIGHWAYS AND TRANSPORTATION COMMISSION

 105 WEST CAPITOL
 JEFFERSON CITY, MO 65102
 1-888-ASK-MODOT (1-888-273-6636)

IF A SEAL IS PRESENT ON THIS SHEET IT HAS BEEN ELECTRONICALLY SEALED AND DATED.

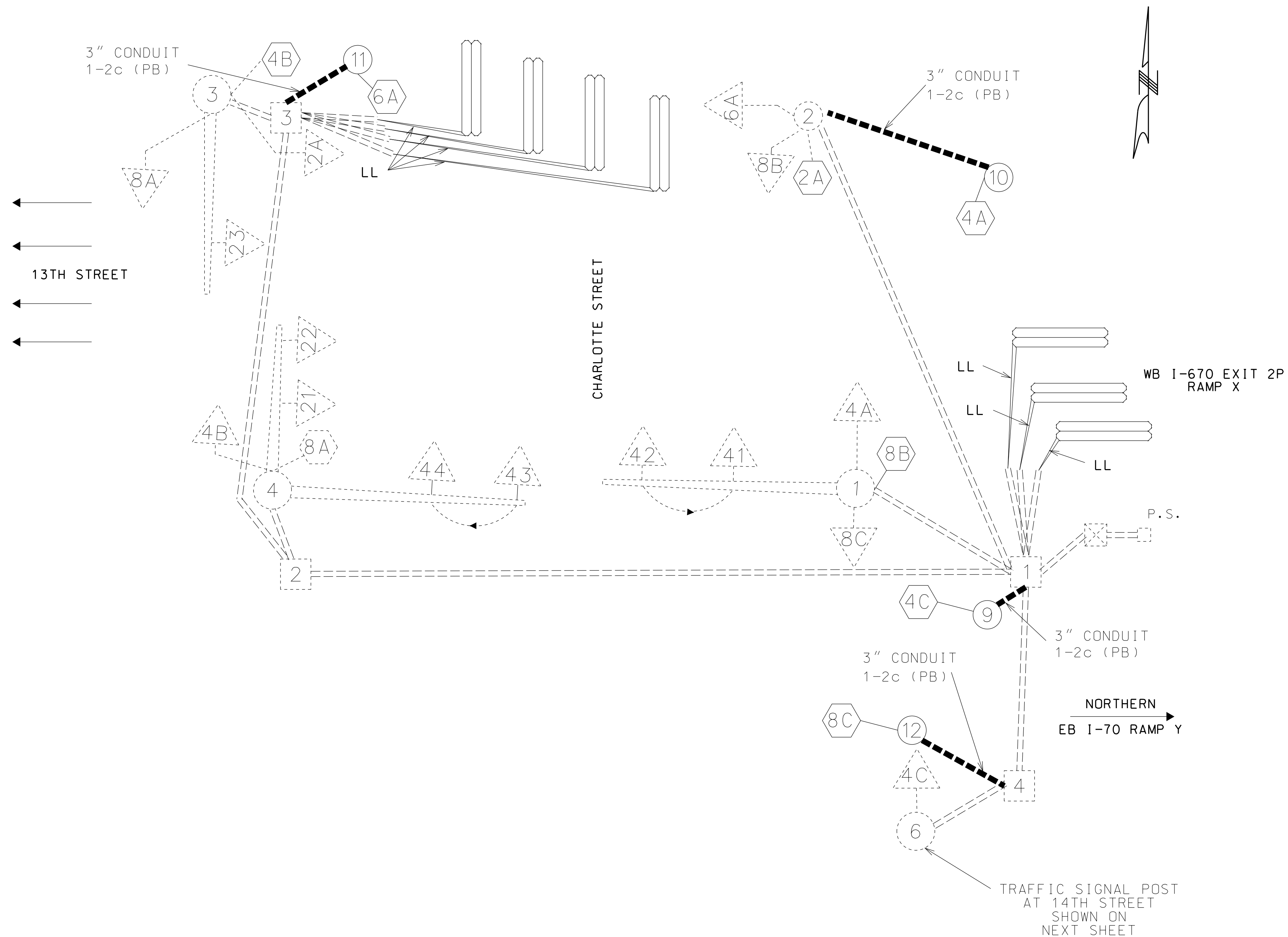
WIRING DIAGRAM



LEGEND

- CONDUIT TRENCHED
 - CONDUIT PUSHED
 - EXISTING CONDUIT
 - SIG VEHICLE SIGNAL CABLE
 - PED PEDESTRIAN SIGNAL CABLE
 - PB PEDESTRIAN PUSH BUTTON CABLE
 - PWR POWER CABLE
 - X-Xc MULTI-CONDUCTOR CABLE #16 AWG (UNLESS OTHERWISE INDICATED)
 - LIC #14 AWG DETECTOR LEAD-IN CABLE (2C TWISTED SHIELDED)
 - LL #14 AWG DETECTOR LOOP LEADS
 - ⊗ SIGNAL PULL BOX WITH NUMBER
 - ⊗ SIGNAL & LIGHTING CONTROLLER
 - P.S. POWER SUPPLY ASSEMBLY
 - ⊗ POST WITH MAST ARM AND WITH NUMBER
 - ⊗ PEDESTRIAN SIGNAL AND/OR PUSH BUTTON POST WITH NUMBER
 - ⊗ PEDESTRIAN PUSH BUTTON DETECTOR WITH NUMBER
 - ⊗ SIGNAL HEAD WITH NUMBER
 - ⏏ TRAFFIC SIGNALS INDUCTION LOOP DETECTOR
- NOTE: DASHED LINES INDICATE EXISTING

CHARLOTTE STREET AT 13TH STREET
INTERSECTION

D-37D SHEET 1 OF 2

SIGNALS SHEET
SHEET 4 OF 7

D-37D

"THIS MEDIA SHOULD NOT BE CONSIDERED A CERTIFIED DOCUMENT."

DATE PREPARED
1/7/2014

ROUTE STATE
I-670 MO

DISTRICT SHEET NO.
KC 25

COUNTY
JACKSON

JOB NO.
J412023

CONTRACT ID.

PROJECT NO.

BRIDGE NO.

DATE	DESCRIPTION

MISSOURI HIGHWAYS AND TRANSPORTATION COMMISSION

MoDOT

105 WEST CAPITOL
JEFFERSON CITY, MO 65102
1-888-ASK-MODOT (1-888-273-6636)

IF A SEAL IS PRESENT ON THIS SHEET IT HAS BEEN ELECTRONICALLY SEALED AND DATED.

WIRING DIAGRAM

LEGEND

- ▬▬▬▬▬ CONDUIT TRENCHED
 - CONDUIT PUSHED
 - ▬▬▬▬▬ EXISTING CONDUIT
 - SIG VEHICLE SIGNAL CABLE
 - PED PEDESTRIAN SIGNAL CABLE
 - PB PEDESTRIAN PUSH BUTTON CABLE
 - PWR POWER CABLE
 - X-Xc MULTI-CONDUCTOR CABLE #16 AWG (UNLESS OTHERWISE INDICATED)
 - LIC #14 AWG DETECTOR LEAD-IN CABLE (2C TWISTED SHIELDED)
 - LL #14 AWG DETECTOR LOOP LEADS
 - ⊗ SIGNAL PULL BOX WITH NUMBER
 - ⊗ SIGNAL & LIGHTING CONTROLLER
 - P.S. POWER SUPPLY ASSEMBLY
 - ⊗ POST WITH MAST ARM AND WITH NUMBER
 - ⊗ PEDESTRIAN SIGNAL AND/OR PUSH BUTTON POST WITH NUMBER
 - ⊗ PEDESTRIAN PUSH BUTTON DETECTOR WITH NUMBER
 - ⊗ SIGNAL HEAD WITH NUMBER
 - ▬▬▬ TRAFFIC SIGNALS INDUCTION LOOP DETECTOR
- NOTE: DASHED LINES INDICATE EXISTING

"THIS MEDIA SHOULD NOT BE CONSIDERED A CERTIFIED DOCUMENT."

DATE PREPARED 1/7/2014	
ROUTE I-670	STATE MO
DISTRICT KC	SHEET NO. 26
COUNTY JACKSON	
JOB NO. J412023	
CONTRACT ID.	
PROJECT NO.	
BRIDGE NO.	

DATE	DESCRIPTION

MISSOURI HIGHWAYS AND TRANSPORTATION COMMISSION



105 WEST CAPITOL
JEFFERSON CITY, MO 65102
1-888-ASK-MODOT (1-888-273-6636)

IF A SEAL IS PRESENT ON THIS SHEET IT HAS BEEN ELECTRONICALLY SEALED AND DATED.

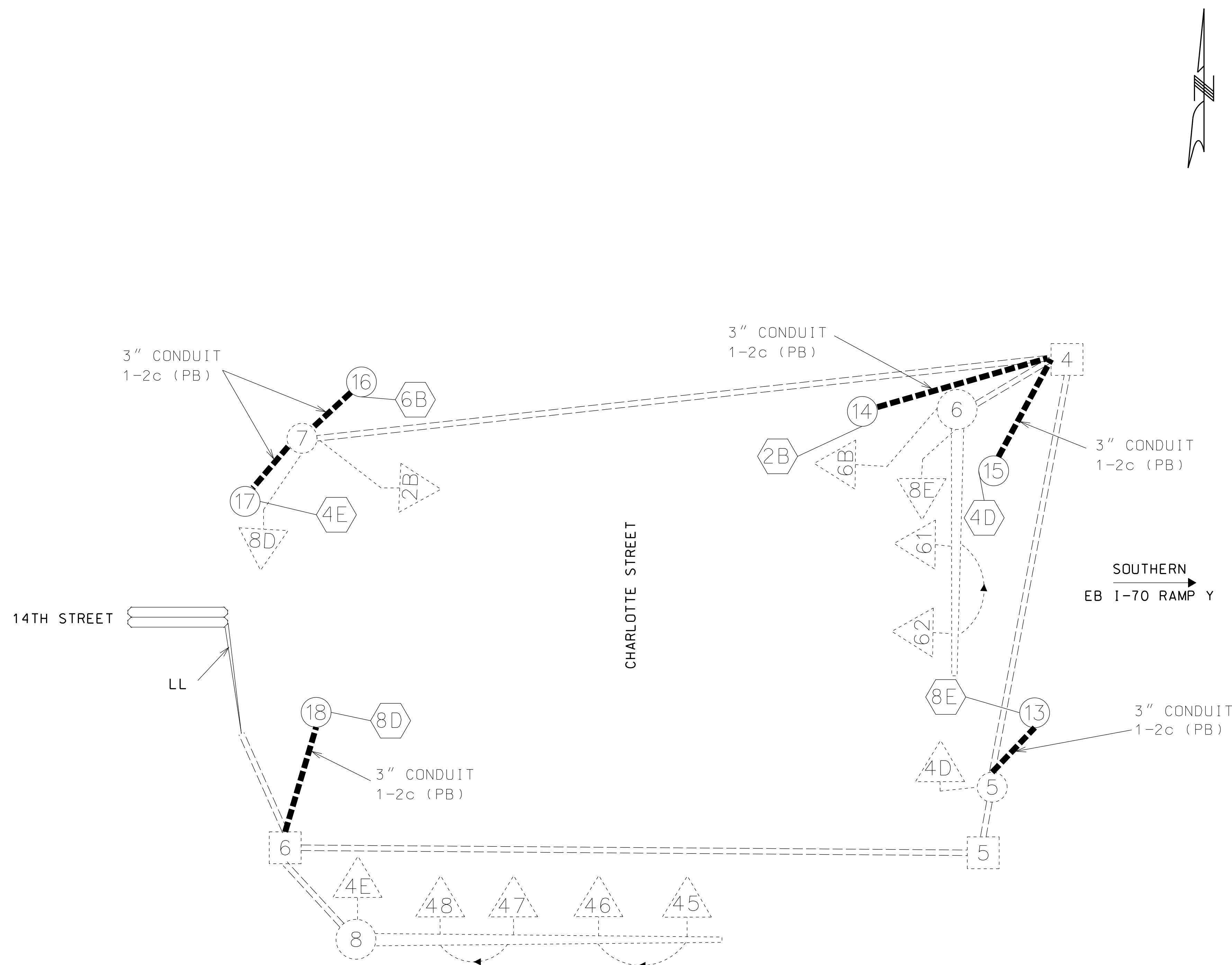

CHARLOTTE STREET AT 14TH STREET
INTERSECTION

D-37D SHEET 2 OF 2

SIGNALS SHEET
SHEET 5 OF 7

D-37D

"THIS MEDIA SHOULD NOT BE CONSIDERED A CERTIFIED DOCUMENT."

DATE PREPARED

1/7/2014

ROUTE STATE

I-670 MO

DISTRICT SHEET NO.

KC 27

COUNTY

JACKSON

JOB NO.

J412023

CONTRACT ID.

PROJECT NO.

BRIDGE NO.

A08073

TRAFFIC PHASING AND COLOR SEQUENCE - ACTUATED CONTROLLERS

		PHASE 1	PHASE 2	PHASE 3	PHASE 4	PHASE 5	PHASE 6	PHASE 7	PHASE 8	PED # 2 OVERLAP	PED # 4 OVERLAP	PED # 6 OVERLAP	PED # 8 OVERLAP					
			←		↓					→	↓							
			←		↓					→	↑							
		21	22	23	41	42	43	44		2A	6A	4B	8A	4A	8B	4C	8C	
FACE NUMBERS	R		R	R	R					DW	DW	DW	DW	DW	DW	DW		R
	Y		Y	Y	Y					FDW	FDW	FDW	FDW	FDW	FDW	FDW		Y
	G		S	S	S					W	W	W	W	W	W	W		G
DETECTOR ASSIGNMENTS		21-23			41-44													
									DETECTOR ASSIGNMENTS (PEDS. ONLY) PB 2A 6A 4B 8A 4A 8B 4C 8C OVERLAP PARENT PHASES									
									DETECTOR ASSIGNMENTS (VEHICLES ONLY)									
									DETECTOR ASSIGNMENTS (OTHERS ONLY)									

DESCRIPTION

DATE

MISSOURI HIGHWAYS AND TRANSPORTATION COMMISSION

105 WEST CAPITOL JEFFERSON CITY, MO 65102 1-888-ASK-MODOT (1-888-273-6636)

IF A SEAL IS PRESENT ON THIS SHEET IT HAS BEEN ELECTRONICALLY SEALED AND DATED.

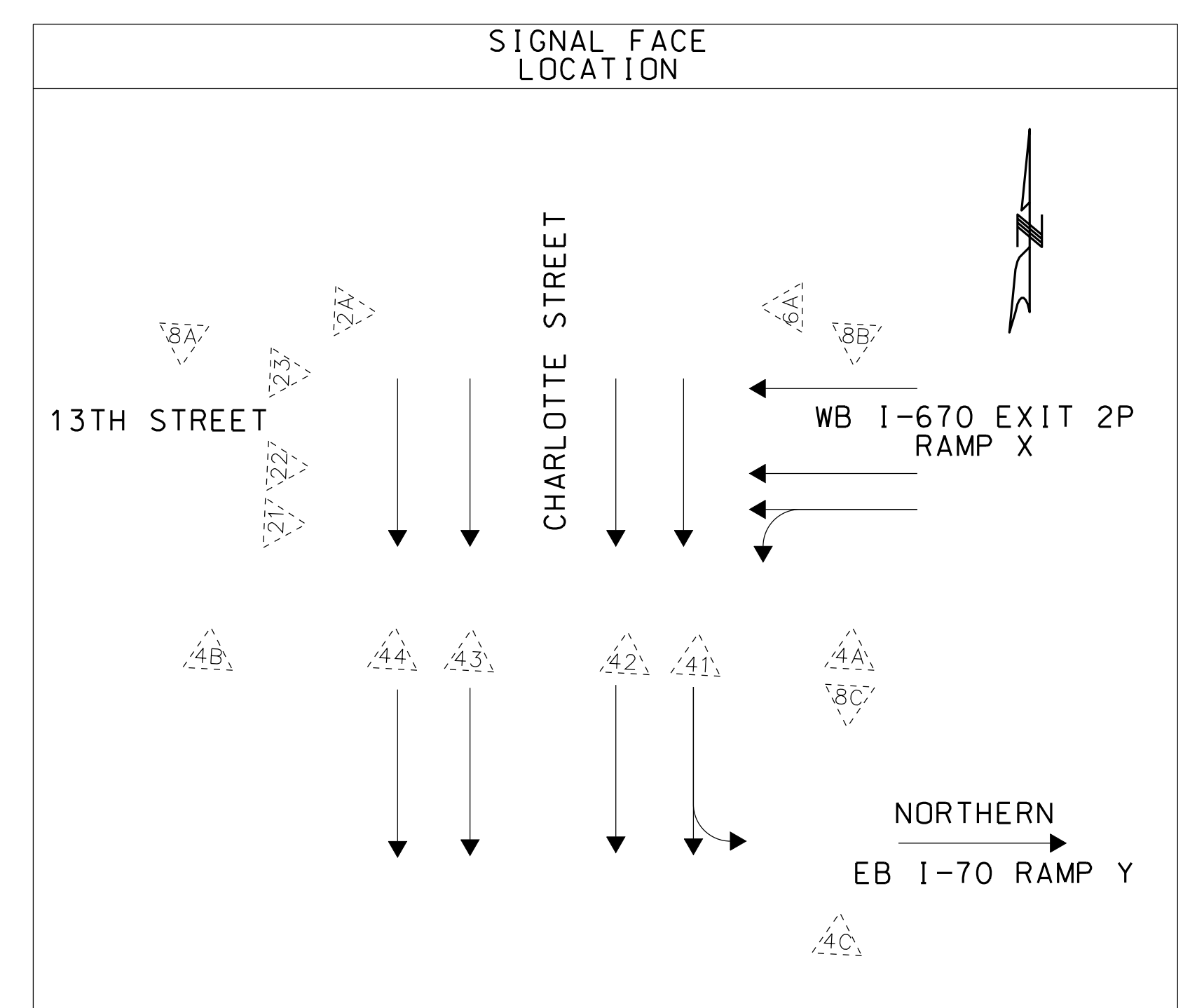
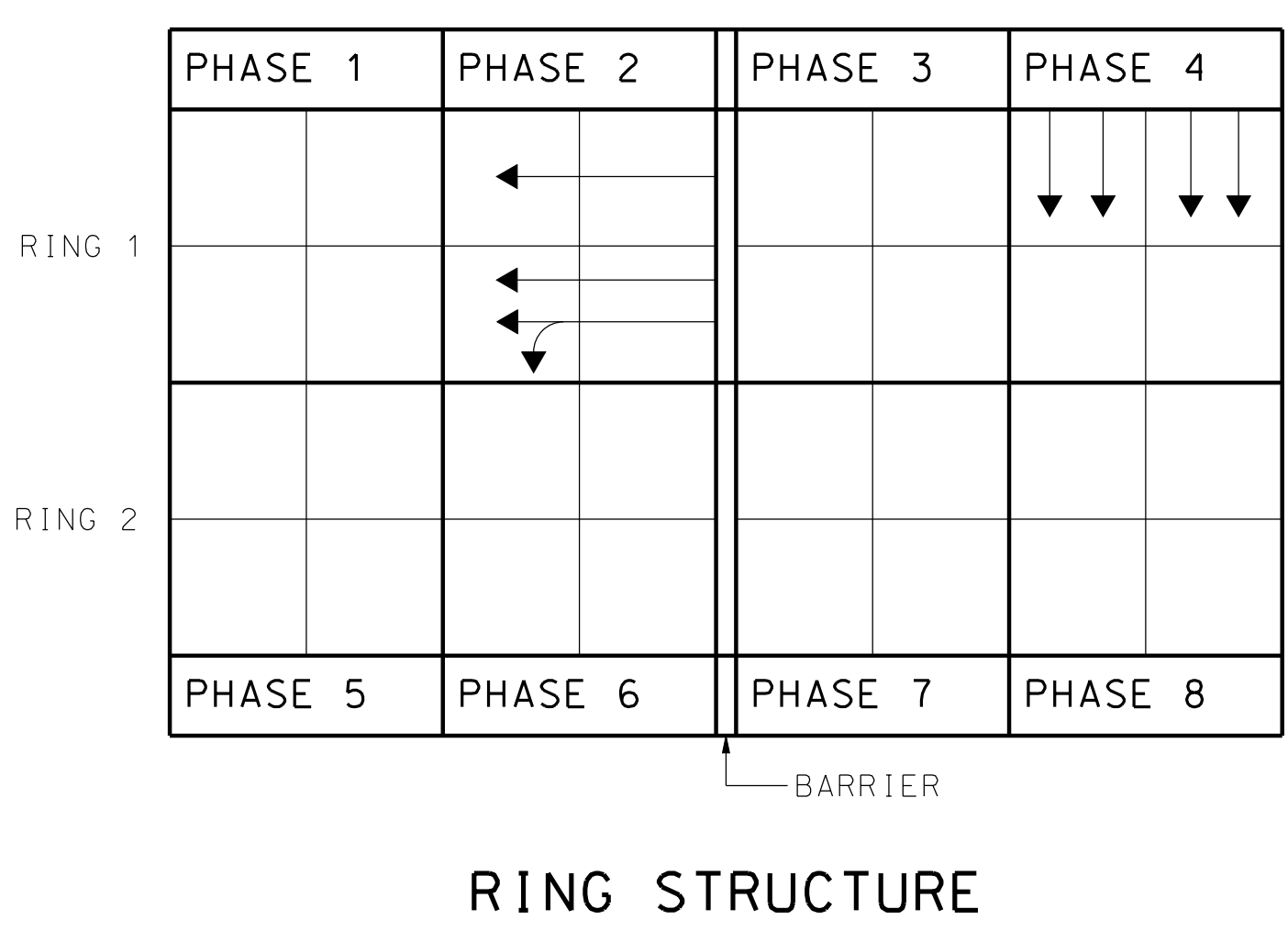

LEGEND

- - ACTUATED VEHICULAR MOVEMENT
- - PARTIALLY RESTRICTED ACTUATED VEHICULAR MOVEMENT
- ↪ - NON-ACTUATED VEHICULAR MOVEMENT
- ↪ - PARTIALLY RESTRICTED NON-ACTUATED VEHICULAR MOVEMENT
- ⇈ - ACTUATED PEDESTRIAN MOVEMENT
- ⇈ - NON-ACTUATED PEDESTRIAN MOVEMENT
- ⊥ - VEHICLE STOPPED
- FDW - FLASHING DON'T WALK
- R/W - RIGHT OF WAY INTERVAL
- DW - DON'T WALK
- YRT - YELLOW RIGHT ARROW
- RT - GREEN RIGHT ARROW
- W - WALK
- LY - YELLOW LEFT ARROW
- L - GREEN LEFT ARROW
- SG - GREEN STRAIGHT AHEAD ARROW
- Y - CIRCULAR YELLOW
- R - CIRCULAR RED
- Ø - TRAFFIC PHASE
- AO - ALL OTHERS
- FR - FLASHING RED
- FY - FLASHING CIRCULAR YELLOW
- FYA - FLASHING YELLOW ARROW
- FYL - FLASHING YELLOW LEFT ARROW
- FYR - FLASHING YELLOW RIGHT ARROW

IF CALLED, ALL NON-CONFLICTING PHASES SHALL COMBINE AND TIME CONCURRENTLY. TIME TO BE DETERMINED BY THE ENGINEER AT SIGNAL TURN ON AND SET IN THE CONTROLLER BY THE CONTRACTOR.

FLASHING OPERATION

--	--

CONTROLLER TYPE NEMA

TRAFFIC SIGNAL CONTROL OPERATION

INTERSECTION OF CHARLOTTE STREET AT 13TH STREET

D-38A SHEET 1 OF 2

SIGNALS SHEET SHEET 6 OF 7

"THIS MEDIA SHOULD NOT BE CONSIDERED A CERTIFIED DOCUMENT."

DATE PREPARED
1/7/2014
ROUTE I-670 STATE MO
DISTRICT KC SHEET NO. 28
COUNTY JACKSON
JOB NO. J412023
CONTRACT ID.

PROJECT NO.
BRIDGE NO. A08073

DESCRIPTION	DATE

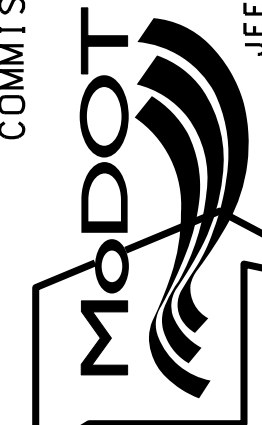
MISSOURI HIGHWAYS AND TRANSPORTATION COMMISSION

 105 WEST CAPITOL
 JEFFERSON CITY, MO 65102
 1-888-ASK-MODOT (1-888-273-6636)

TRAFFIC PHASING AND COLOR SEQUENCE - ACTUATED CONTROLLERS

		PHASE 1	PHASE 2	PHASE 3	PHASE 4	PHASE 5	PHASE 6	PHASE 7	PHASE 8	PED # 2 OVERLAP	PED # 4 OVERLAP	PED # 6 OVERLAP	PED # 8 OVERLAP		
FACE NUMBERS					45 47 46 48		61 62				4E 8D 4D 8E	2B 6B		FACE NUMBERS	
SIGNAL INDICATIONS					R R Y Y S S		R Y S				DW DW DW DW DW DW FDW FDW FDW FDW FDW FDW W W W W W W			SIGNAL INDICATIONS	
DETECTOR ASSIGNMENTS					45-48		61-62							DETECTOR ASSIGNMENTS	
											PB 4E PB 8D PB 4D PB 8E PB 2B PB 6B			DETECTOR ASSIGNMENTS	
														OVERLAP PARENT PHASES	

	PHASE 1	PHASE 2	PHASE 3	PHASE 4
RING 1				↓ ↓ ↓ ↓
RING 2		→		
	PHASE 5	PHASE 6	PHASE 7	PHASE 8

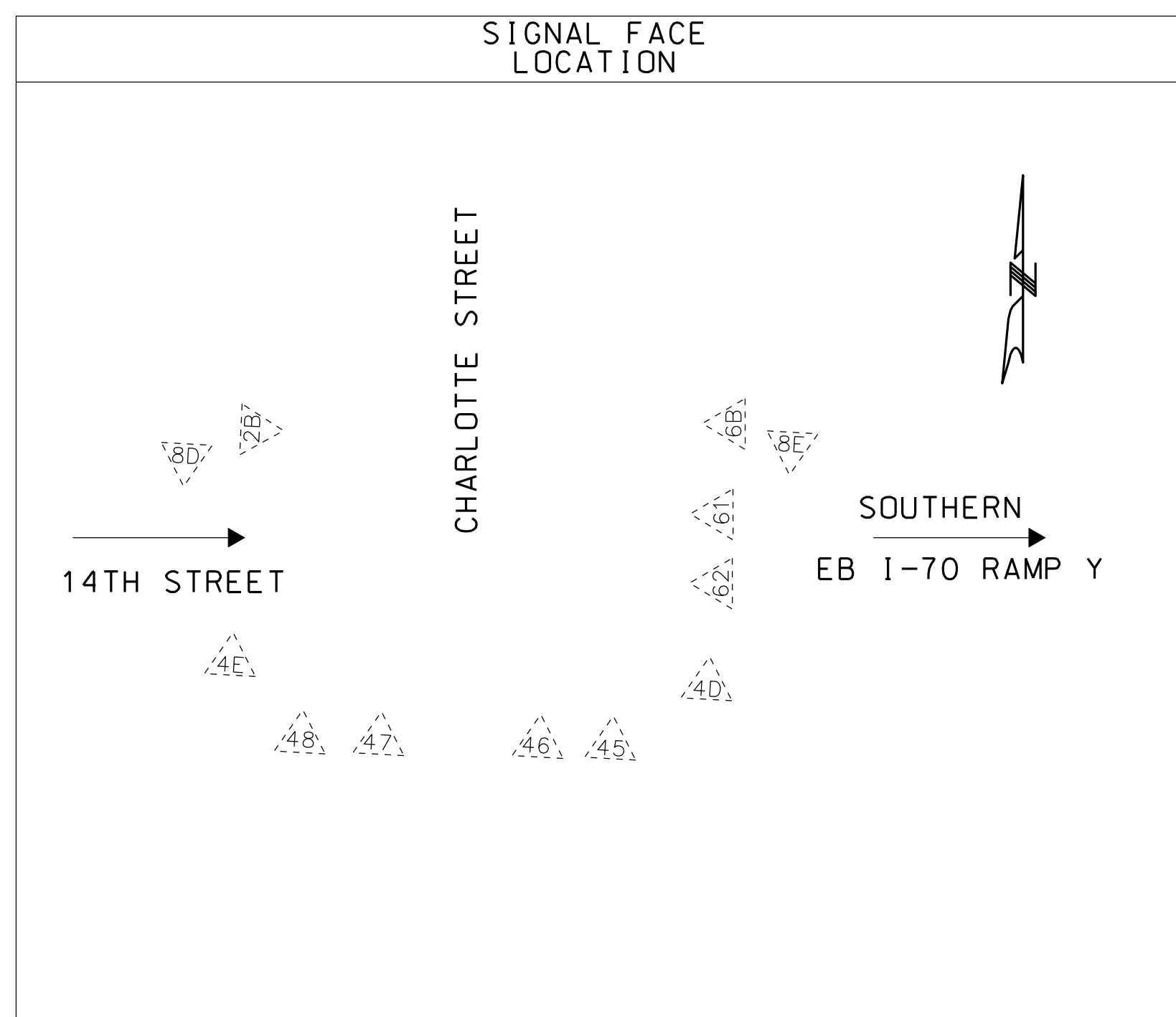
RING STRUCTURE



IF CALLED, ALL NON-CONFLICTING PHASES SHALL COMBINE AND TIME CONCURRENTLY. TIME TO BE DETERMINED BY THE ENGINEER AT SIGNAL TURN ON AND SET IN THE CONTROLLER BY THE CONTRACTOR.

FLASHING OPERATION	
CONTROLLER TYPE	NEMA

LEGEND

- ACTUATED VEHICULAR MOVEMENT
- PARTIALLY RESTRICTED ACTUATED VEHICULAR MOVEMENT
- NON-ACTUATED VEHICULAR MOVEMENT
- PARTIALLY RESTRICTED NON-ACTUATED VEHICULAR MOVEMENT
- ACTUATED PEDESTRIAN MOVEMENT
- NON-ACTUATED PEDESTRIAN MOVEMENT
- VEHICLE STOPPED
- FDW - FLASHING DON'T WALK
- R/W - RIGHT OF WAY INTERVAL
- DW - DON'T WALK
- YRT - YELLOW RIGHT ARROW
- RT. - GREEN RIGHT ARROW
- W - WALK
- LY - YELLOW LEFT ARROW
- L - GREEN LEFT ARROW
- S - GREEN STRAIGHT AHEAD ARROW
- CG - CIRCULAR GREEN
- CY - CIRCULAR YELLOW
- CR - CIRCULAR RED
- TR - TRAFFIC PHASE
- AO - ALL OTHERS
- FR - FLASHING RED
- FY - FLASHING CIRCULAR YELLOW
- FYA - FLASHING YELLOW ARROW
- FYL - FLASHING YELLOW LEFT ARROW
- FYR - FLASHING YELLOW RIGHT ARROW

TRAFFIC SIGNAL CONTROL OPERATION

INTERSECTION OF
CHARLOTTE STREET AT 14TH STREET

D-38A SHEET 2 OF 2

SIGNALS SHEET
SHEET 7 OF 7

IF A SEAL IS PRESENT ON THIS SHEET IT HAS BEEN ELECTRONICALLY SEALED AND DATED.

"THIS MEDIA SHOULD NOT BE CONSIDERED A CERTIFIED DOCUMENT."

SIGNS					PIPE POST				STRUCTURAL STEEL POSTS				BACKING BARS			TOTAL ITEM NO. 903-12.10	U-CHANNEL POST	WOOD POSTS			PERF. STEEL SQ.		BREAKAWAY ASSEMBLY	CONC FTG'S EMBD	CONC FTG'S BOLT DOWN	HORZ CLEAR IF NOT STD	DELINEATORS, MILEPOSTS, CONDUIT, CONDUCTOR CABLE, TRENCHING AND BACKFILLING, CONTROL STATION, PULL BOXES AND OTHER REQUIRED ITEMS.	
SIGN NO.	STATION	SIGN DTL. SHT. NO.	LOCATION	SIGN SIZE	PIPE SIZE	POST NO. 1	POST NO. 2	LBS PER FT	TOTAL ITEM NO. 903-12.20	POST DES NO.	POST NO. 1	POST NO. 2	POST NO. 3	LBS PER FT	TOTAL	TOTAL	ITEM NO. 903-12.50	4"X4" ITEM NO. 903-12.60	4"X6" ITEM NO. 903-12.61	6"X6" ITEM NO. 903-12.62	POSTS ITEM NO. 903-12.70	ANCHOR SLEEVE ITEM NO. 903-12.71	ITEM NO. 903-12.40	ITEM NO. 903-10.10	ITEM NO. 903-10.20	STD		
																												NO. EACH
1	1+90	STD.	53' RT.	36X36	2.5			5.79	88																			
TOTAL									90														1		0.1			

DATE PREPARED
1/7/2014

ROUTE 1-670	STATE MO
DISTRICT KC	SHEET NO. 29
COUNTY JACKSON	
JOB NO. J412023	
CONTRACT ID.	
PROJECT NO.	
BRIDGE NO. A08073	

STANDARD SIGN ASSEMBLIES										SIGN SUMMARY															
SIGN NUMBER	STATION	LOCATION	TYPE							STANDARD SIGN OR SPECIAL SIGN NUMBER	SIGN DETAIL SHEET NO.	NO. EACH	SIZE, TYPE & SQUARE FEET								48" STOP EACH	36" STOP EACH			
			SHR2L-1	SHR2L-2	SHR2L-3	STR2L-1	STR2L-2	STR2L-3	SHR4L-1				STR4L-1	SHR4L-3	STR4L-3	SIZE	SHR2L-1 ITEM NO. 903-50.04	STR2L-1 ITEM NO. 903-50.64	SHR2L-3 ITEM NO. 903-50.65	STR2L-3 ITEM NO. 903-50.11			SHR4L-1 ITEM NO. 903-50.69	STR4L-1 ITEM NO. 903-50.71	SHR4L-3 ITEM NO. 903-50.70
1	1+90	53' RT.								1	STD.	1	36X36	9.0											
2	VARIOUS	BRIDGE FENCE								6	STD.	6	12X18	9.0											
3	VARIOUS	* ON BRIDGE								6	STD.	6	84X24	84.0											
TOTAL												102													

* INSTALL AT LOCATIONS ON THE BRIDGE AS DIRECTED BY THE ENGINEER

DESCRIPTION	DATE

MISSOURI HIGHWAYS AND TRANSPORTATION COMMISSION

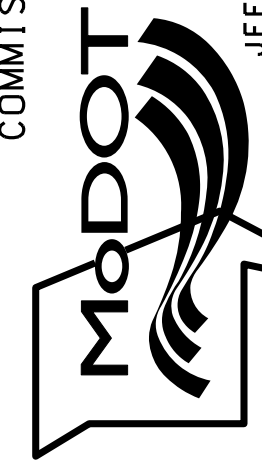

105 WEST CAPITOL
JEFFERSON CITY, MO 65102
1-888-ASK-MODOT (1-888-273-6636)

IF A SEAL IS PRESENT ON THIS SHEET IT HAS BEEN ELECTRONICALLY SEALED AND DATED.

MISSOURI HIGHWAYS AND TRANSPORTATION COMMISSION

SEC/SUR 5 TWP 49N RGE 33W

U.I.P. & REHAB EXISTING (44'-80'-80'-80'-88'-88'-73'-43') CONTINUOUS CONCRETE BOX GIRDER SPANS

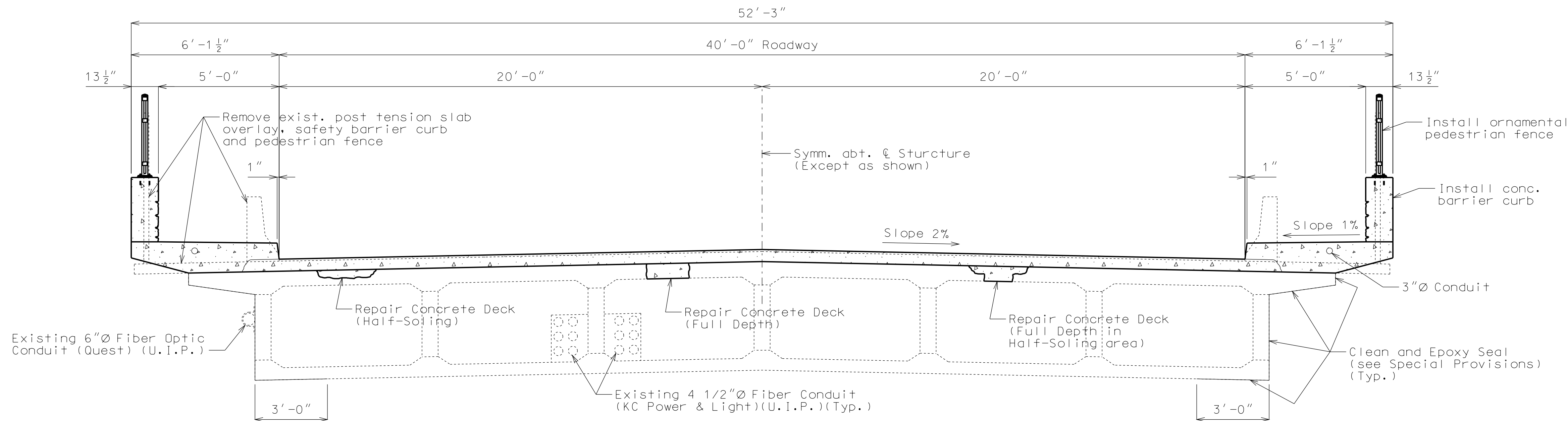

TYPICAL SECTION THRU SLAB

General Notes:

- Design Specifications:
 2002 - AASHTO (17th Edition) Standard Specifications)
 Load Factor Design
 Seismic Performance Category A
 Bridge Deck Rating = 5
- Design Loading:
 H20-S16-44 (1957)
 HS20-44 and Military 24,000# Tandem Axle (1982 & New Construction)
- Design Unit Stresses:
 Class B-1 Concrete (Corral Curb) $f'c = 4,000$ psi
 Class B-2 Concrete (Superstructure except Corral Curb) $f'c = 4,000$ psi
 Reinforcing Steel (Grade 60) $fy = 60,000$ psi
- Joint Filler:
 All joint filler shall be in accordance with Sec 1057 for preformed sponge rubber expansion and partition joint filler, except as noted.
- Reinforcing Steel:
 Minimum clearance to reinforcing steel shall be 1 1/2", unless otherwise shown.
- Miscellaneous:
 Bars bonded in old concrete not removed shall be cleanly stripped and embedded into new concrete where possible. If length is available, old bars shall extend into new concrete at least 40 diameters for smooth bars and 30 diameters for deformed bars, unless otherwise noted.
 Outline of old work is indicated by light dashed lines. Heavy lines indicate new work.
 Contractor shall verify all dimensions in field before ordering new material.
 The area exposed by the removal of concrete and not covered with new concrete shall be coated with an approved qualified special mortar in accordance with Sec 704.
 The contractor shall exercise extreme caution during removal of post-tensioned slab.
- Protective Coating:
 Protective coating for concrete bents and piers (Epoxy) shall be applied as shown on bridge plans and in accordance with Sec 711.
- Traffic Handling:
 Structure to be closed during construction.

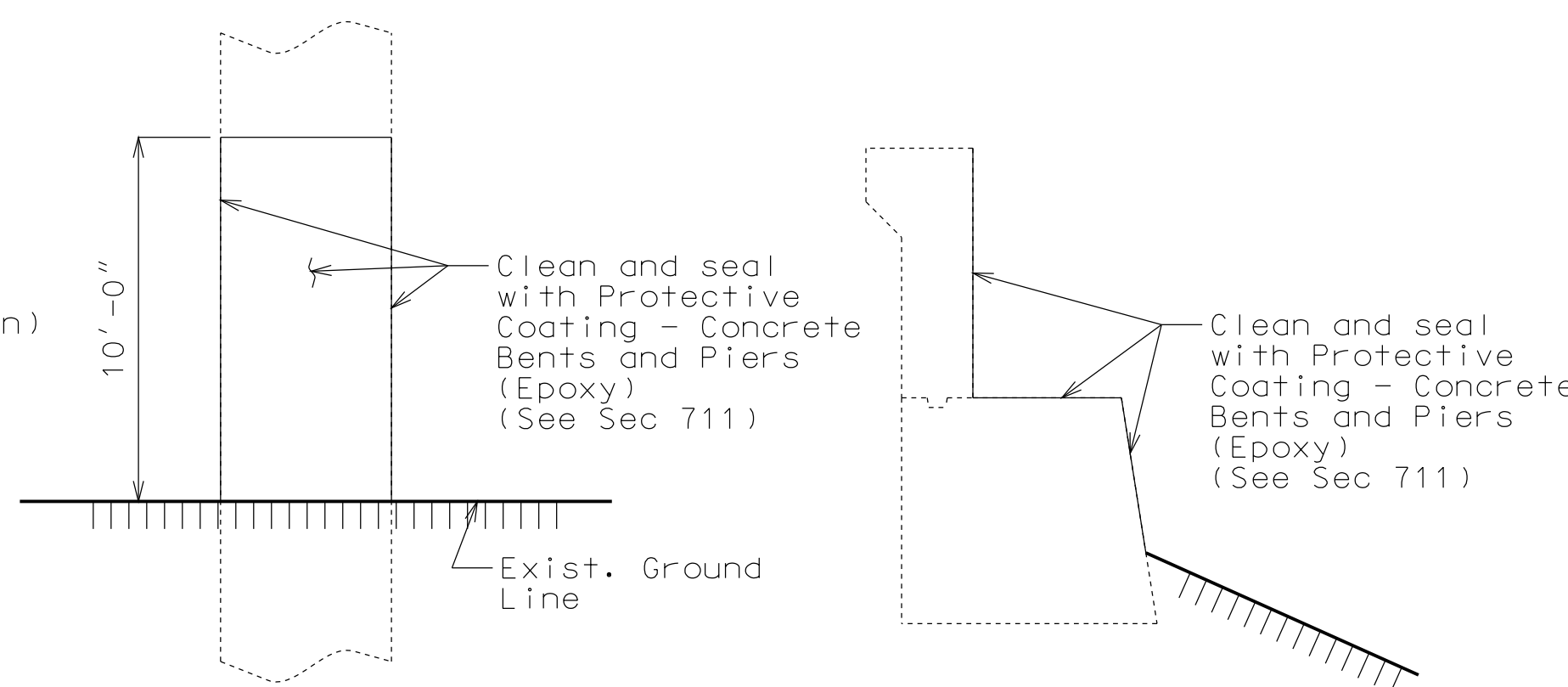

TYPICAL ELEVATION OF EXISTING COLUMNS AT INT. BENTS 2 THRU 8 SHOWING PROTECTIVE COATING

TYPICAL SECTION THRU END BENTS SHOWING PROTECTIVE COATING

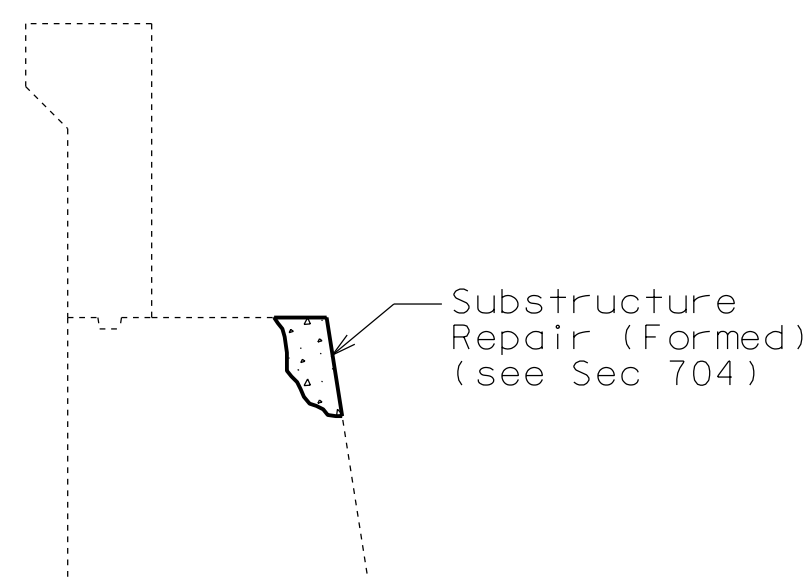

TYPICAL SECTION THRU END BENTS SHOWING SUBSTRUCTURE REPAIR

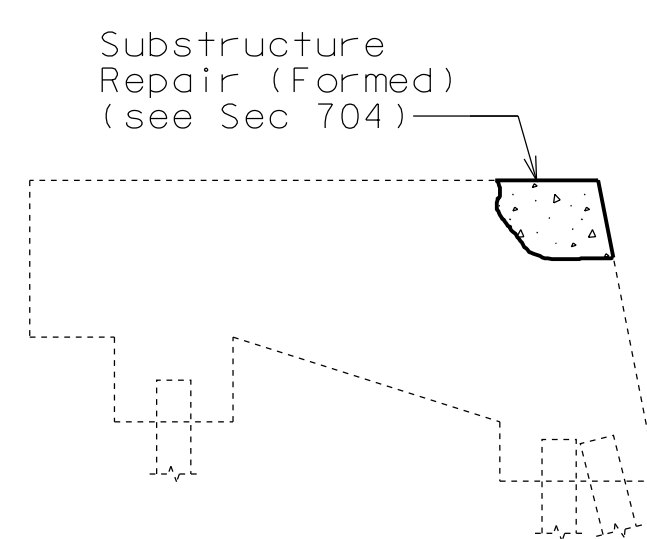

TYPICAL ELEVATION AT END BENTS SHOWING SUBSTRUCTURE REPAIR

Estimated Quantities		
Item		Total
Removal of Post-tensioned Slab	sq. foot	30,205
Reinforced Concrete Slab Overlay	sq. yard	3357
Corral Curb	linear foot	1253
Form Liners	sq. yard	266
Substructure Repair (Formed)	sq. foot	100
Repairing Concrete Deck (Half-Soling)	sq. foot	3100
Full Depth Repair	sq. foot	400
Clean and Epoxy Seal	sq. foot	11,385
Conduit System on Structure	lump sum	1
Protective Coating - Concrete Bents and Piers (Epoxy)	lump sum	1
Cleaning and Coating Existing Bearings	each	14
Fabricated Sign Support Brackets	lump sum	1
(48 in.) Ornamental Pedestrian Fence (Structures)	linear foot	1211
Strip Seal Expansion Joint System	linear foot	112

Estimated Quantities for Reinforced Concrete Slab Overlay		
Item		Total
Class B-2 Concrete	cu. yard	736.8
Reinforcing Steel (Epoxy Coated)	pound	95,210

The table of Estimated Quantities for Reinforced Concrete Slab Overlay represents the quantities used by the State in preparing the cost estimate for concrete slabs. The area of the concrete slab will be measured to the nearest square yard from end of slab to end of slab and the overall width shown in the Typical Section Thru Slab. Payment for conventional forms, all concrete and coated reinforcing steel will be considered completely covered by the contract unit price for the slab.

Class B-2 concrete quantity is based on minimum 6" slab thickness.

BRIDGE: CHARLOTTE STREET OVER RTE. I-670

STATE ROAD FROM I-70 WEST TO I-35

IN KANSAS CITY

STA. 2+68.90± (Match Exist.)

STD. 706.35

"THIS MEDIA SHOULD NOT BE CONSIDERED A CERTIFIED DOCUMENT."

DATE PREPARED
 1/22/2014

ROUTE
 I-670

STATE
 MO

DISTRICT
 BR

SHEET NO.
 1

COUNTY
 JACKSON

JOB NO.
 J412023

CONTRACT ID.

PROJECT NO.

BRIDGE NO.
 A08073

DESCRIPTION

DATE

MISSOURI HIGHWAYS AND TRANSPORTATION COMMISSION

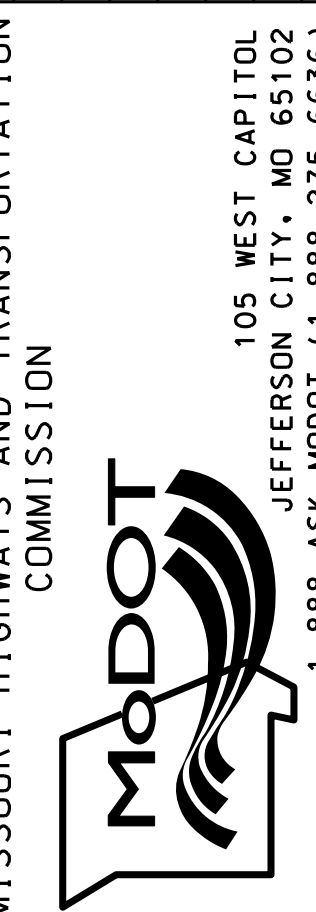

IF A SEAL IS PRESENT ON THIS SHEET IT HAS BEEN ELECTRONICALLY SEALED AND DATED.

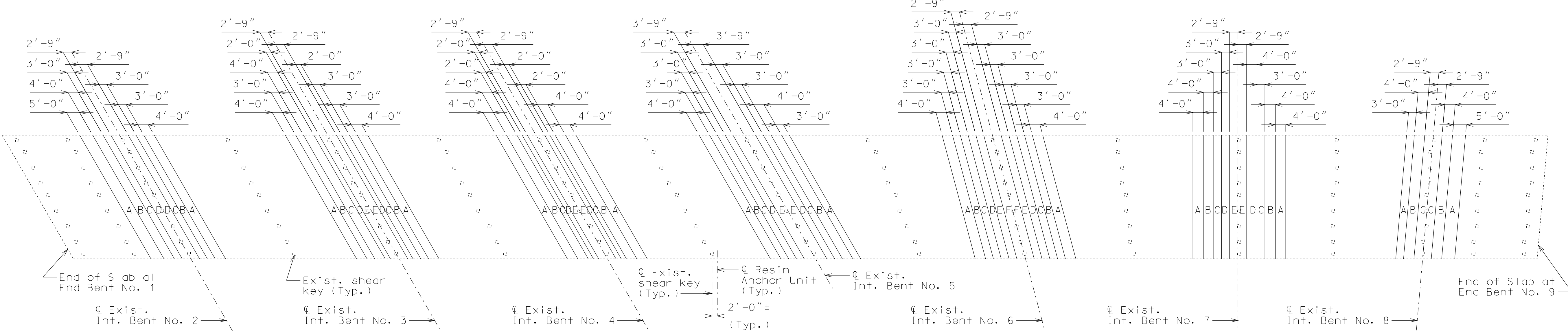

PLAN OF SLAB SHOWING SPECIAL REPAIR ZONES AND LOCATIONS OF RESIN ANCHOR UNITS

Note: Dimensions shown are horizontal dimensions along ϕ Roadway.

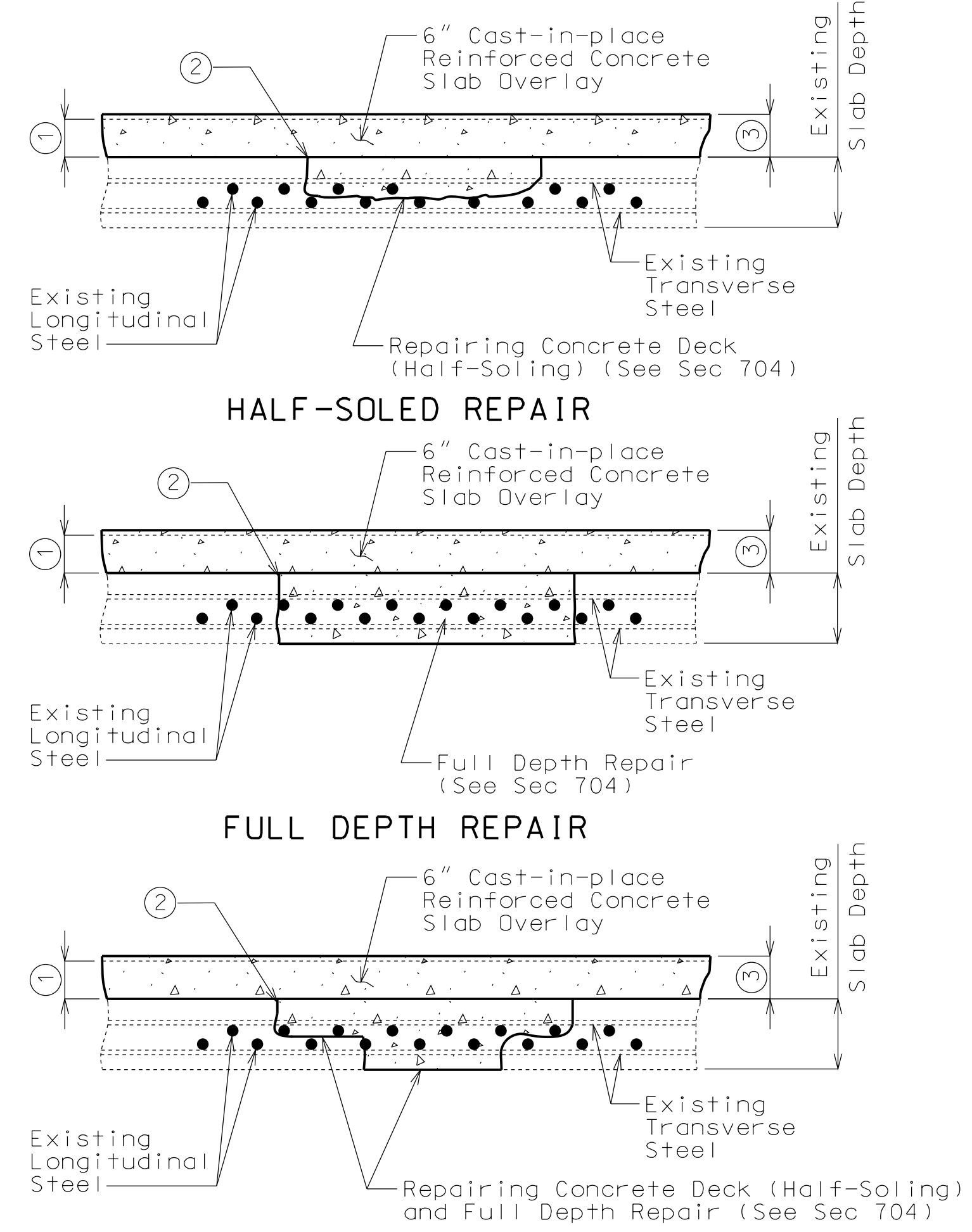

DECK REPAIR DETAILS

- 1 Remove existing 5" post tension slab overlay.
- 2 One inch vertical side shall be established outside the deteriorated area. See Sec 704.
- 3 6" cast-in-place slab (Class B-2 Concrete) overlay.

Notes:
Any half-soling required in the areas designated as special repair zones shall be completed in alphabetical sequence. Any repair in the remainder of the bridge that is adjacent to areas A and not designated as a special repair zone shall be completed prior to work in Zone A.

Removal and repair shall be completed in one special repair zone and concrete shall have attained a compressive strength of 3200 psi before work can be started in the next special repair zone. Before placing concrete in areas adjacent to areas of subsequent repair, the concrete shall be separated with a material such as polyethylene sheets to aid in removal of old concrete.

Zones with the same letter designation may be repaired at the same time.

If any single repair area does not exceed 9 square feet in size and the total repair within a special repair zone does not exceed 27 square feet, the special repair zone requirement does not apply for that zone. Half-soling repair in the special repair zone, on either side of the intermediate bents, shall be to a depth that will not expose half the diameter of the longitudinal reinforcing bar. Full depth repair shall be made when removal of deteriorated concrete exposes half or more of the diameter of the longitudinal reinforcing bar.

Total width of full depth repair shall not exceed 1/3 of the deck width at one time. For any area of deck repair that extends over a concrete girder and is more than 18 inches in length along the girder, the concrete removal shall stop at the centerline of girder and repair completed in this area. Prior to continuing work in this area, the concrete shall have attained a compressive strength of 3200 psi. No traffic shall be permitted over the girder that is undergoing repair.

When the full depth repair extends over a diaphragm or girder and the deteriorated concrete extends into the diaphragm or girder, all deteriorated concrete shall be removed and replaced as full depth repair. Concrete in girders shall not be removed below the deck haunch of the girder without prior review and approval from the engineer.

Interior falsework installed by the contractor resting on the bottom slab shall be removed where entry access is available.

Notes:
Contractor may use in-place existing anchor bolts and reinforcing steel at existing shear key locations. Anchor bolts and reinforcing steel shall be cleanly stripped and embedded in new concrete. If damaged, anchor bolts and reinforcing steel shall be replaced to the satisfaction of the engineer. No additional payment will be made for this option.

If existing anchor bolts and reinforcing steel are not reused, contractor shall install resin anchor systems near existing shear block locations. Locations may be shifted to clear reinforcement or other obstructions. The total number of resin anchor systems shall not be changed.

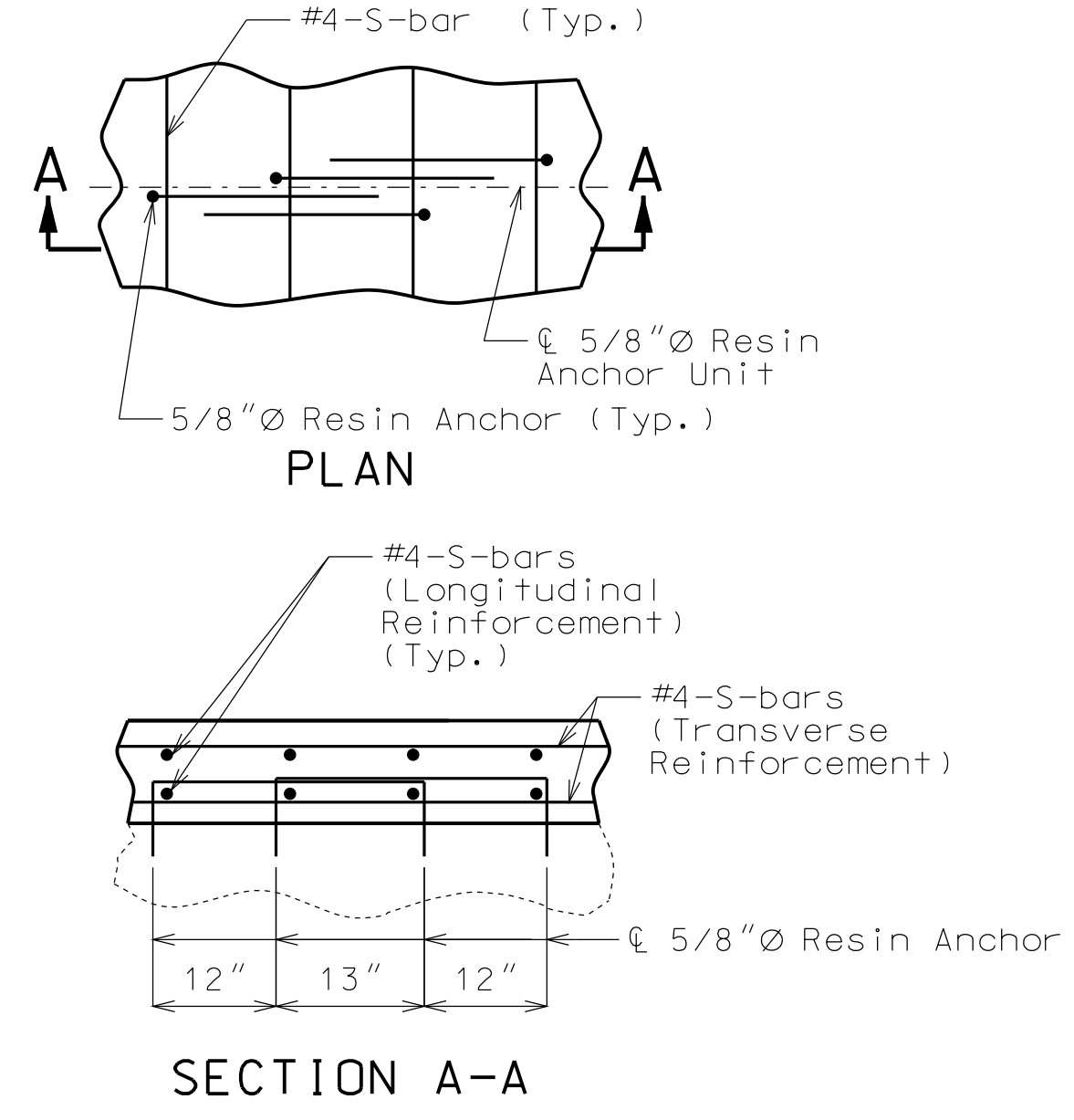

DETAIL OF RESIN ANCHOR UNIT

Resin Anchor Notes:
The contractor shall use one of the qualified resin anchor systems in accordance with Sec 1039.

Cost of furnishing and installing the resin anchor system, complete in place, will be considered completely covered by the contract unit price for Reinforced Concrete Slab Overlay.

The minimum embedment depth in concrete with $f'c = 4,000$ psi for the resin anchor system shall be that required to meet the minimum ultimate pullout strength in accordance with Sec 1039 but shall not be less than 5".

An epoxy coated #5 Grade 60 reinforcing bar 2'-0" long shall be substituted for the 5/8"Ø threaded rod.

"THIS MEDIA SHOULD NOT BE CONSIDERED A CERTIFIED DOCUMENT."

DATE PREPARED		1/22/2014
ROUTE	STATE	I-670 MO
DISTRICT	SHEET NO.	BR 2
COUNTY		
JACKSON		
JOB NO.		
J412023		
CONTRACT ID.		
PROJECT NO.		
BRIDGE NO.		
A08073		

DESCRIPTION	DATE

MISSOURI HIGHWAYS AND TRANSPORTATION COMMISSION

105 WEST CAPITOL JEFFERSON CITY, MO 65102
1-888-ASK-MODOT (1-888-275-6636)

IF A SEAL IS PRESENT ON THIS SHEET IT HAS BEEN ELECTRONICALLY SEALED AND DATED.

1/2"Ø Machine bolt at abt. 18" cts. Use two hex nuts to set gap before concrete placement. Gap may be set anytime up to but not exceeding 2 hours before concrete placement. Cut machine bolt flush with steel armor after concrete on each side has taken initial set.

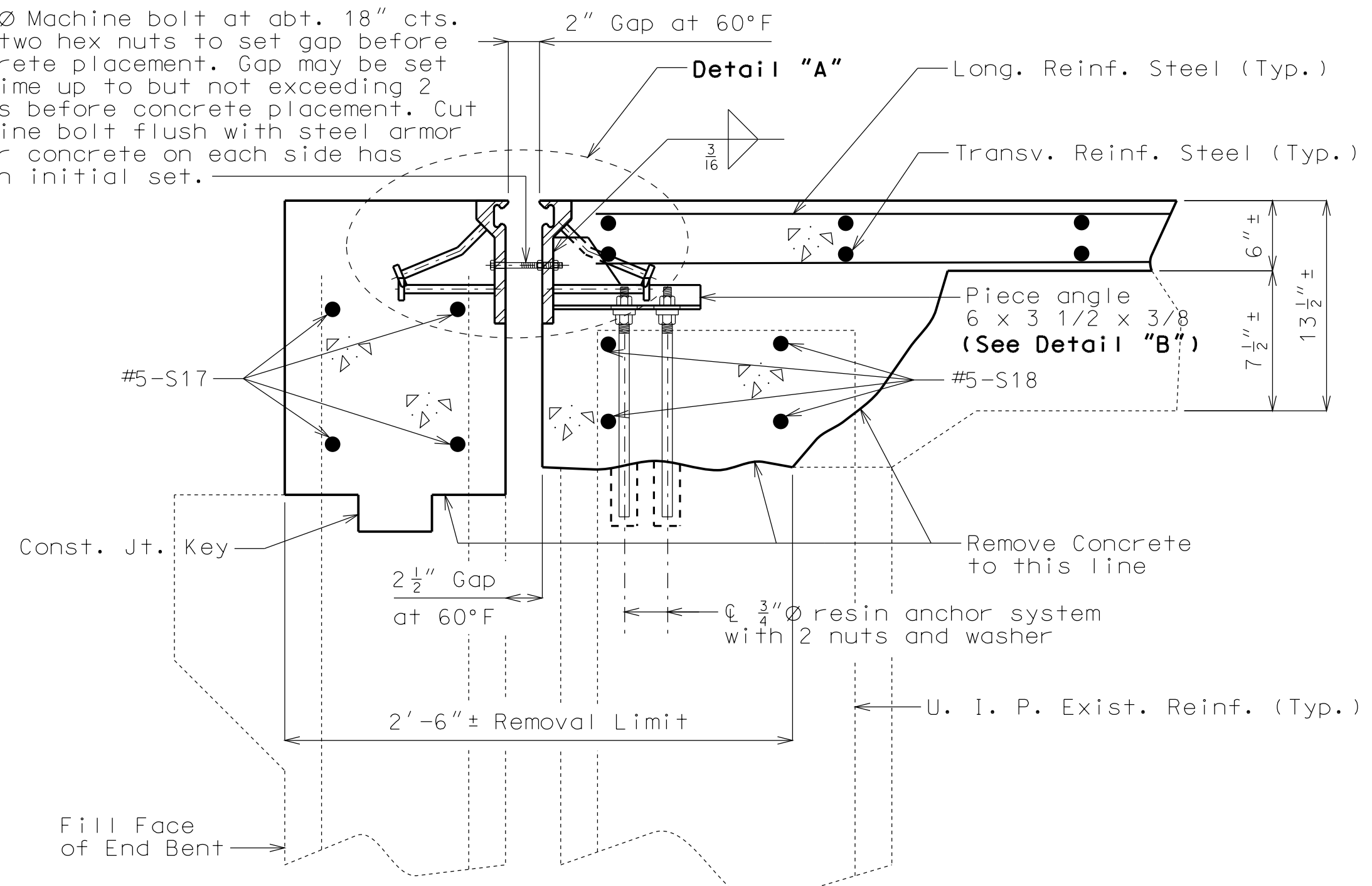

SECTION A-A

Note: Strip seal gland not shown for clarity.

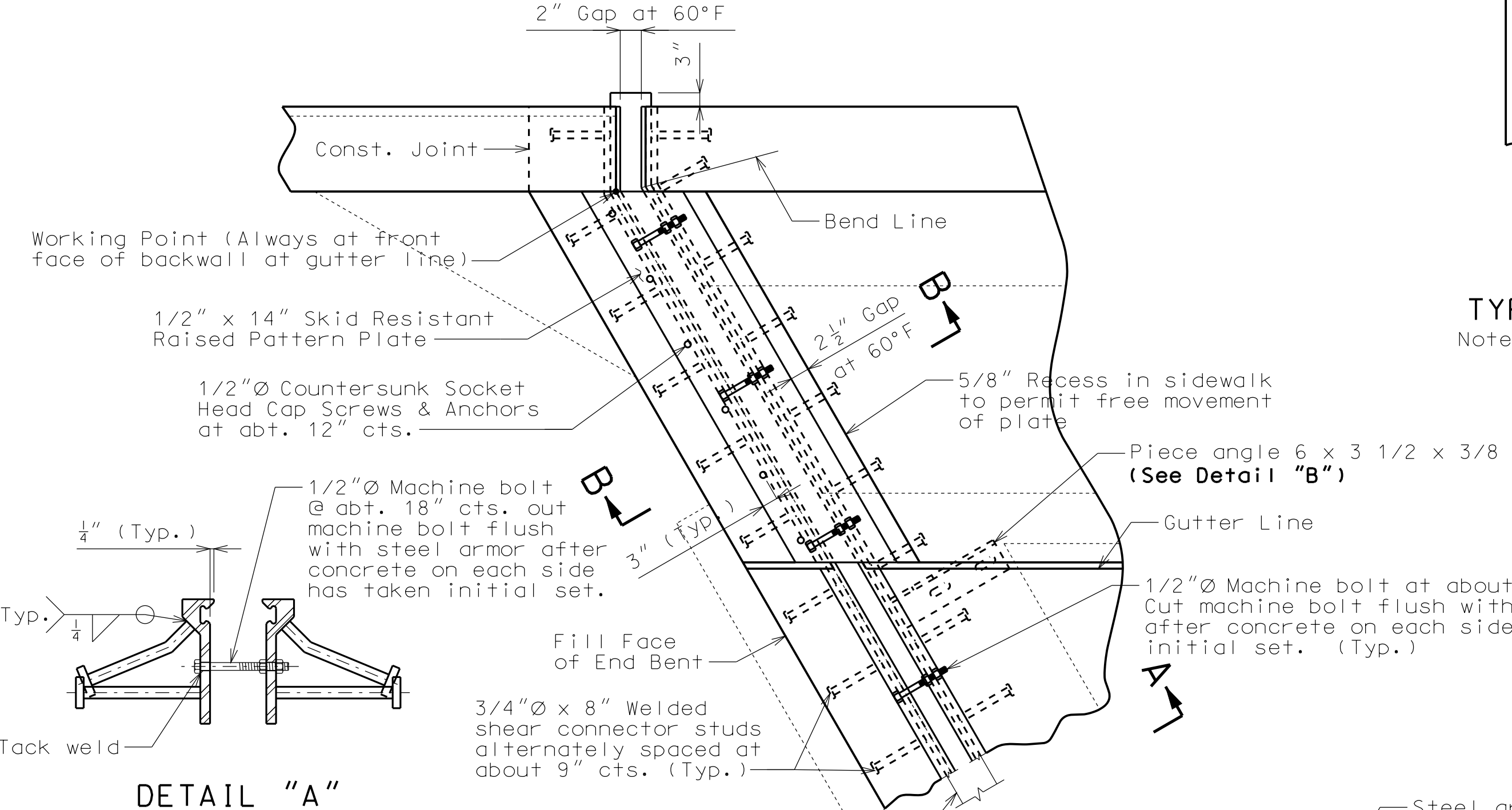

**SECTION B-B
TYPICAL SECTION OF SKID PLATE**

Note: Strip seal gland not shown for clarity.

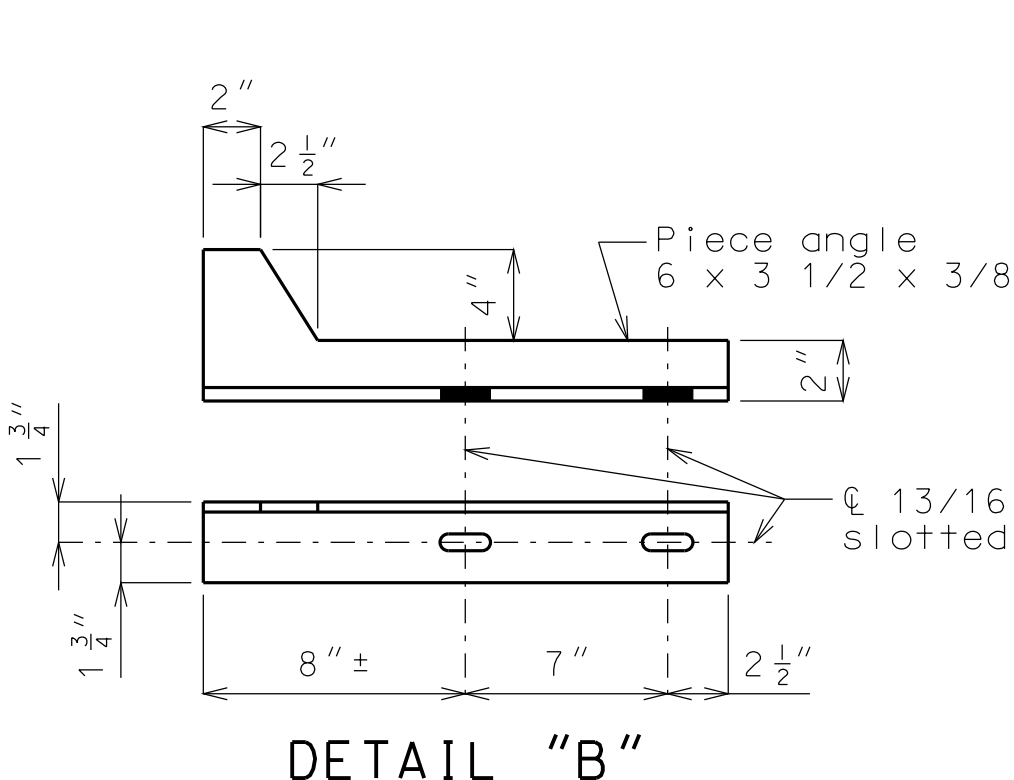

DETAIL "A"

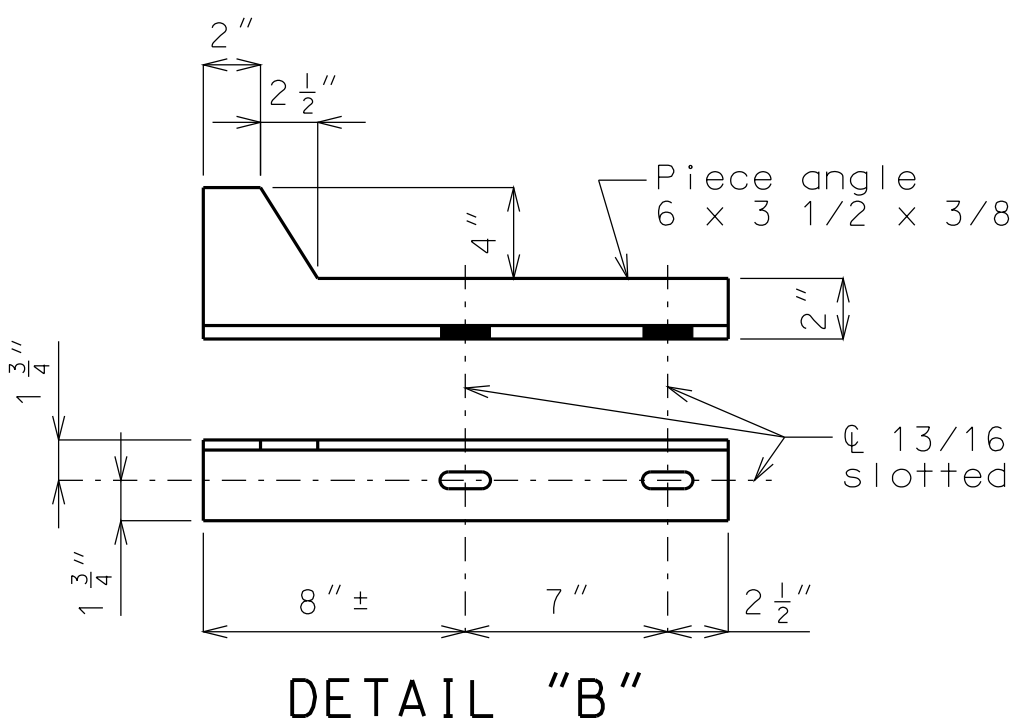

DETAIL "B"

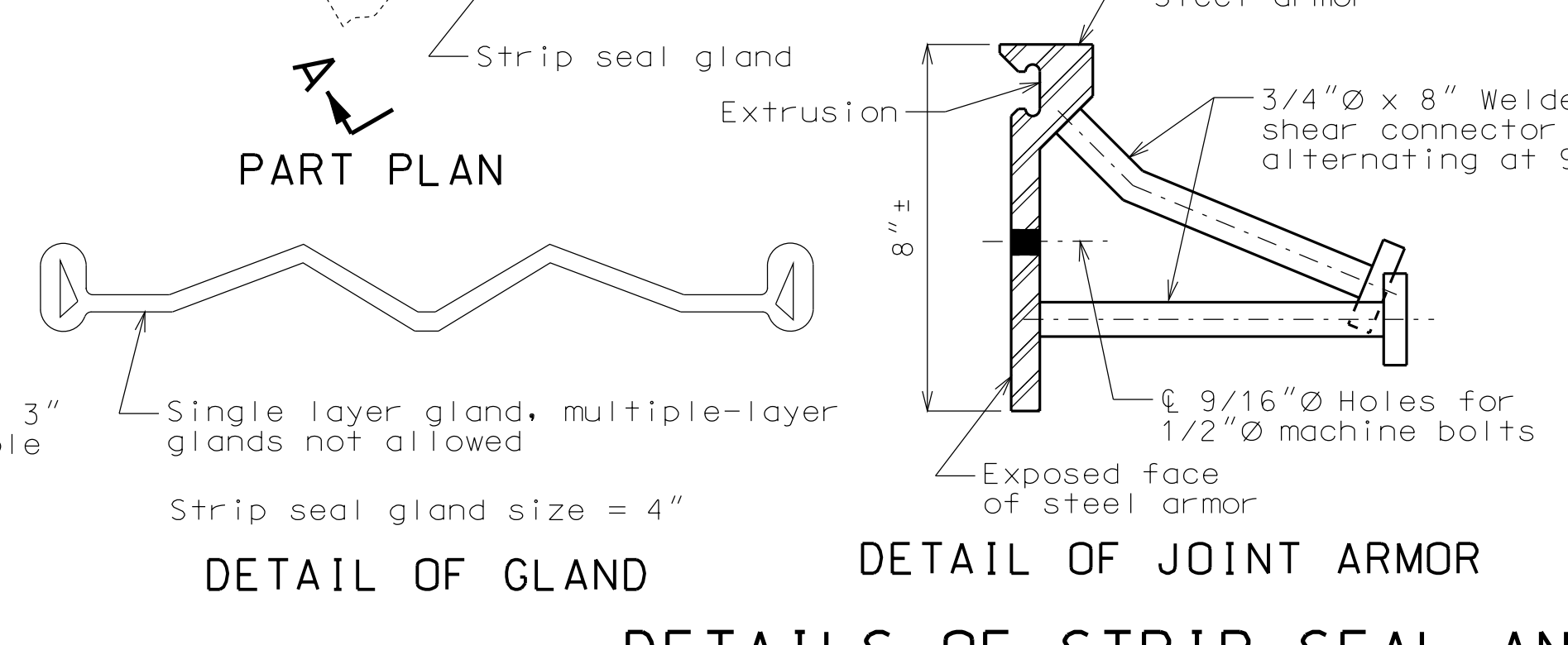

DETAIL OF JOINT ARMOR



DETAIL OF GLAND



PART SECTION NEAR STRIP SEAL JOINT

Detailed Dec. 2013
Checked Jan. 2014

Note: This drawing is not to scale. Follow dimensions.

Sheet No. 3 of 19

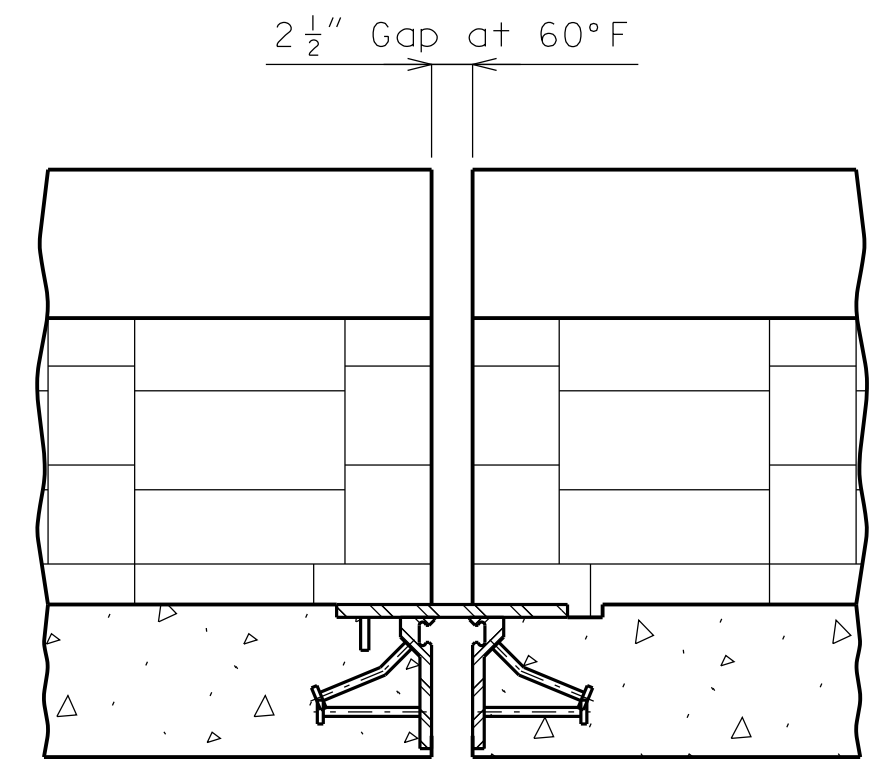

Note: Strip seal gland not shown for clarity.

**PART SECTION THRU SIDEWALK
NEAR CORRAL CURB**

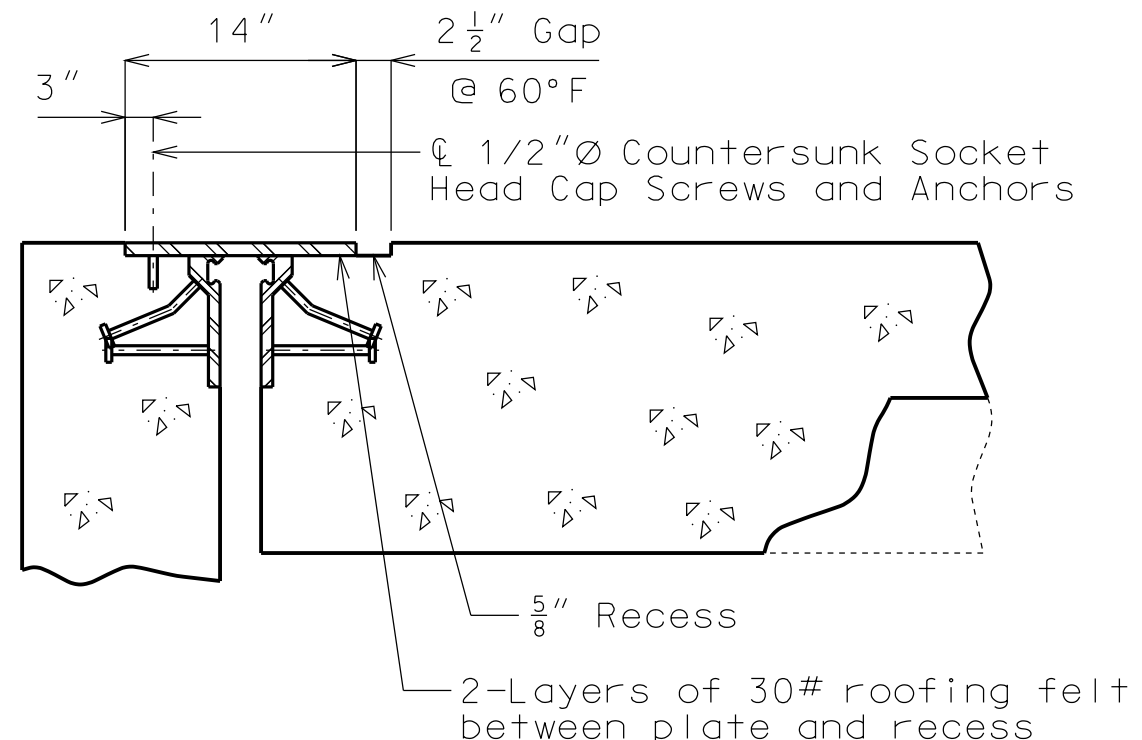

**SECTION B-B
TYPICAL SECTION OF SKID PLATE**

Note: Strip seal gland not shown for clarity.

GENERAL NOTES:

Expansion joint system shall be fabricated in one section, except for stage construction and when the length is over 50 feet. A complete joint penetration groove welded splice shall be required. Welds shall be ground flush to provide a smooth surface. The expansion joint system shall be fabricated and installed to the crown and grade of the roadway.

The strip seal gland shall be installed in joints in one continuous piece without field splices. Factory splicing will be permitted for joints in excess of 53 feet.

Structural steel for the expansion joint system shall be ASTM A709 Grade 36 except the steel armor may be ASTM A709 Grade 50W. Anchors for the expansion joint system shall be in accordance with Sec 1037. Strip seal expansion joint system shall be in accordance with Sec 717.

Structural steel for the expansion joint system shall be coated with a minimum of two coats of inorganic zinc primer (5 mils minimum) or galvanized in accordance with ASTM A123. Anchors need not be protected from overspray.

Plan dimensions are based on installation at 60°F. The expansion gap and other dimensions shall be increased or decreased 3/16" for each 10° fall or rise in temperature at installation.

Concrete shall be forced under and around steel armor and anchors. Proper consolidation of the concrete shall be achieved by localized internal vibration.

Longitudinal reinforcing steel shall be placed so that ends shall not be more than ±1" from vertical leg of the steel armor at the expansion joint system.

Top of backwall for End Bent No. 1 shall be formed to the crown and grade of the roadway. Backwall above upper construction joint shall not be poured until the superstructure slab has been poured in the adjacent span.

All concrete above the upper construction joint in backwall shall be Class B-2.

The contractor shall use one of the qualified resin anchor systems in accordance with Sec 1039.

Cost of furnishing and installing the resin anchor system, complete in place, will be considered completely covered by the contract unit price for Reinforced Concrete Slab Overlay.

The minimum embedment depth in concrete with f'c = 4,000 psi for the resin anchor system shall be that required to meet the minimum ultimate pullout strength in accordance with Sec 1039 but shall not be less than 5".

Measurement of strip seal expansion joint system is to the nearest linear foot for each structure, measured along the front face of backwall from roadway face to roadway face of corral curb.

Note: Cost of skid resistant pattern plate and anchors, complete in place, will be considered completely covered by the contract unit price for Strip Seal Expansion Joint System.

The 1/2" diameter cone expansion anchors shall have a minimum ultimate pullout strength of 7,500 lbs. in concrete with f'c = 4,000 psi.

"THIS MEDIA SHOULD NOT BE CONSIDERED A CERTIFIED DOCUMENT."

DATE PREPARED 1/22/2014	
ROUTE I-670	STATE MO
DISTRICT BR	SHEET NO. 3

COUNTY JACKSON	
JOB NO. J412023	
CONTRACT ID.	

PROJECT NO.	
BRIDGE NO. A08073	

DESCRIPTION	DATE

MISSOURI HIGHWAYS AND TRANSPORTATION COMMISSION



105 WEST CAPITOL
JEFFERSON CITY, MO 65102
1-888-ASK-MODOT (1-888-275-6636)

IF A SEAL IS PRESENT ON THIS SHEET IT HAS BEEN ELECTRONICALLY SEALED AND DATED.

1/2"Ø Machine bolt at abt. 18" cts. Use two hex nuts to set gap before concrete placement. Gap may be set anytime up to but not exceeding 2 hours before concrete placement. Cut machine bolt flush with steel armor after concrete on each side has taken initial set.

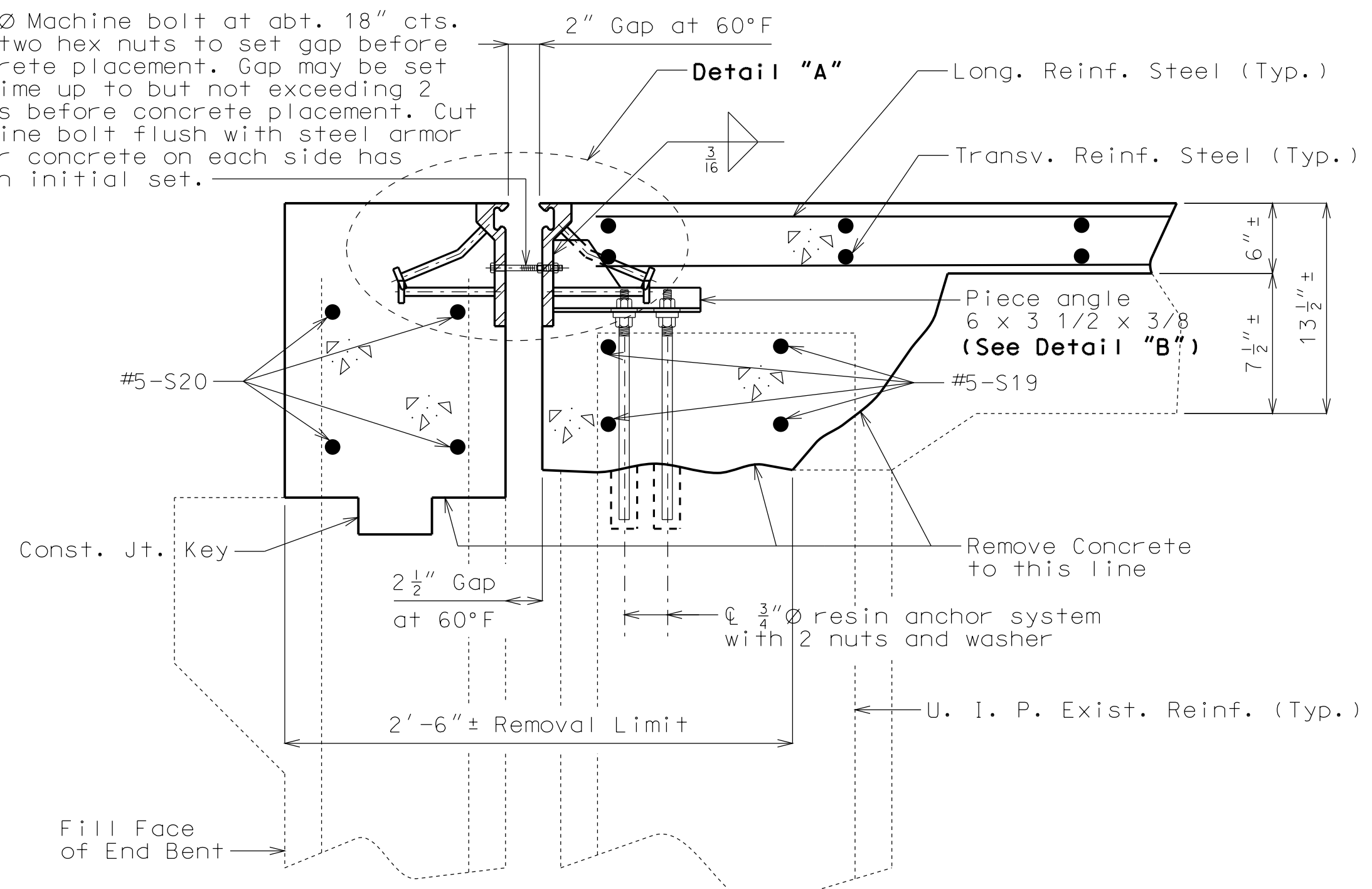

SECTION A-A

Note: Strip seal gland not shown for clarity.

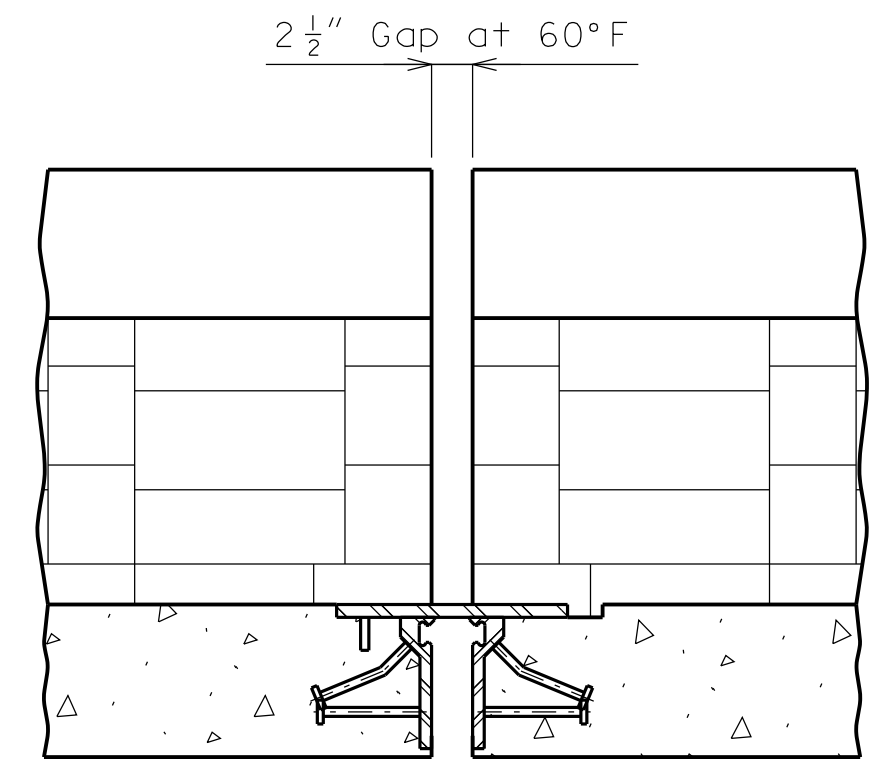

PART SECTION THRU SIDEWALK NEAR CORRAL CURB

Note: Strip seal gland not shown for clarity.

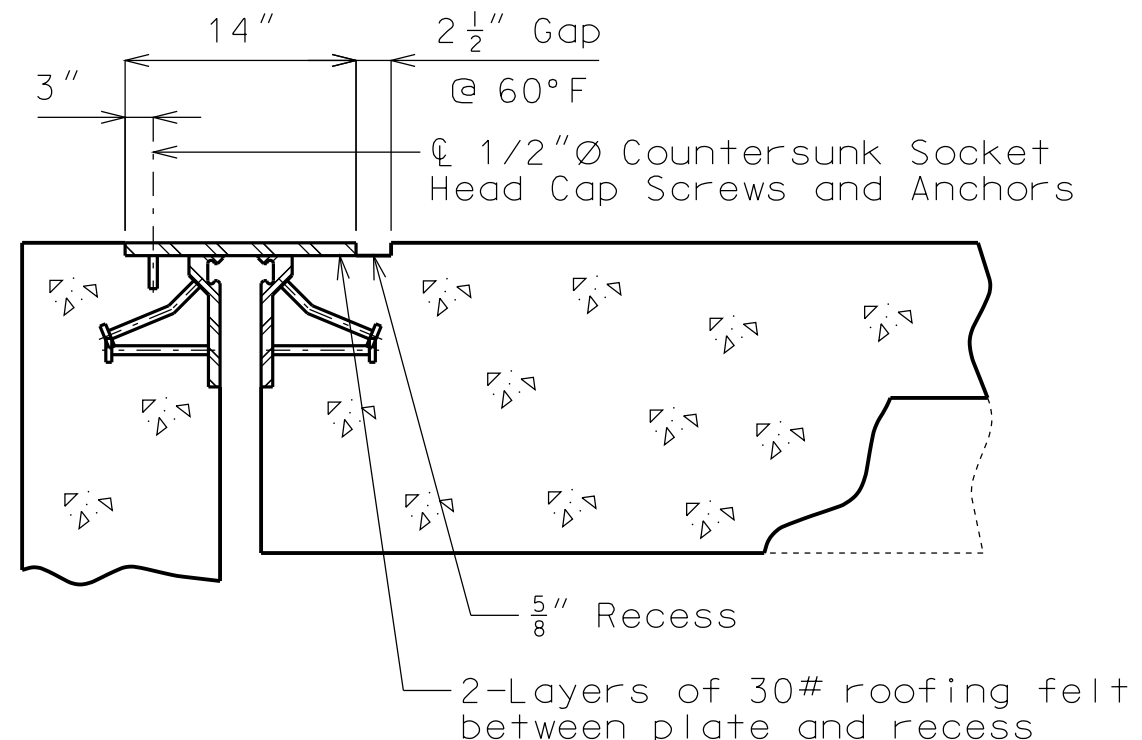

SECTION B-B TYPICAL SECTION OF SKID PLATE

Note: Strip seal gland not shown for clarity.

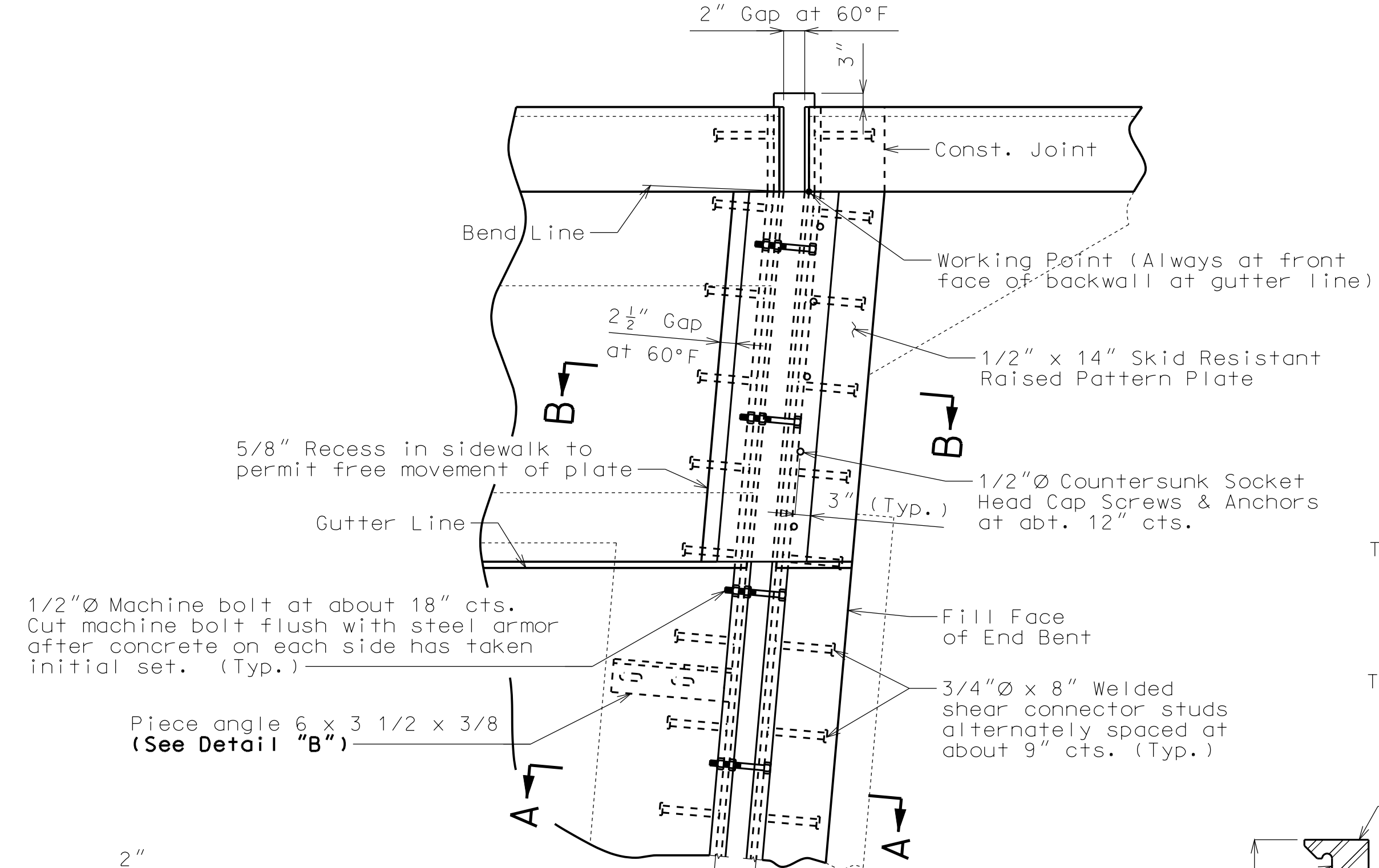

PART PLAN

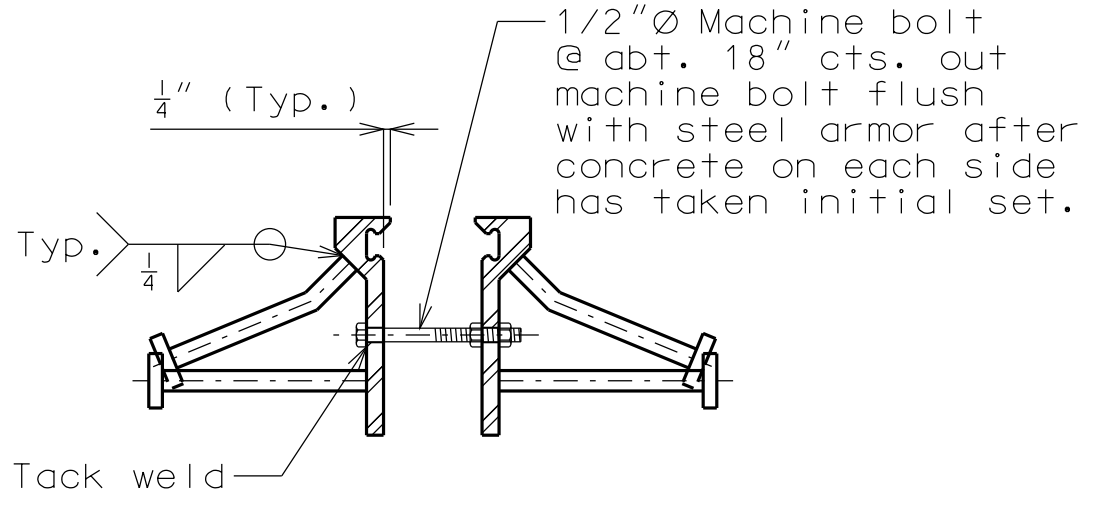

DETAIL "A"

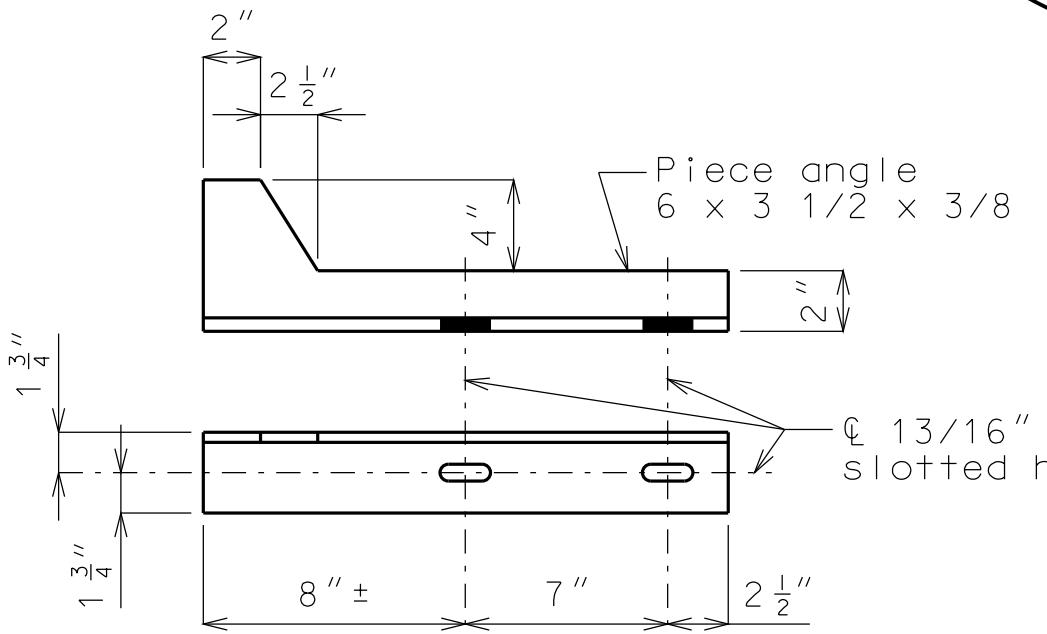

DETAIL "B"

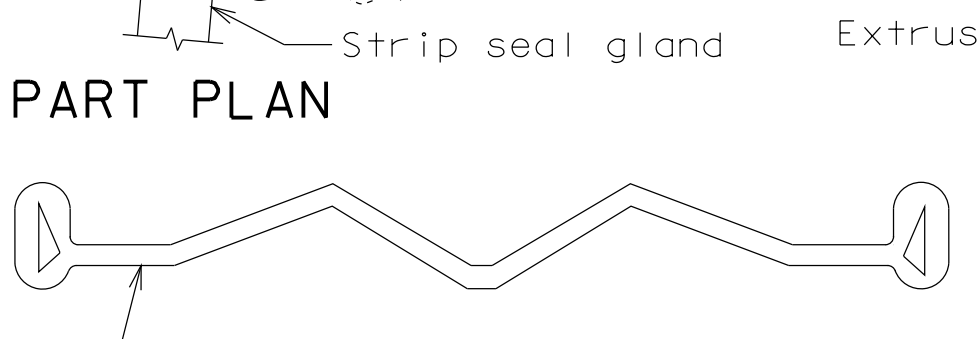

DETAIL OF GLAND

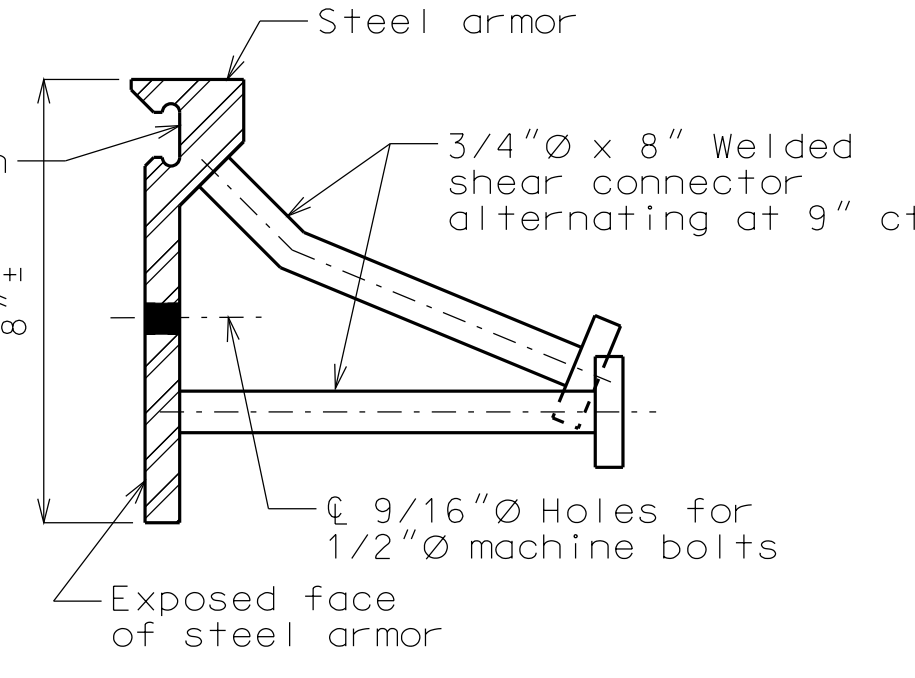

DETAIL OF JOINT ARMOR

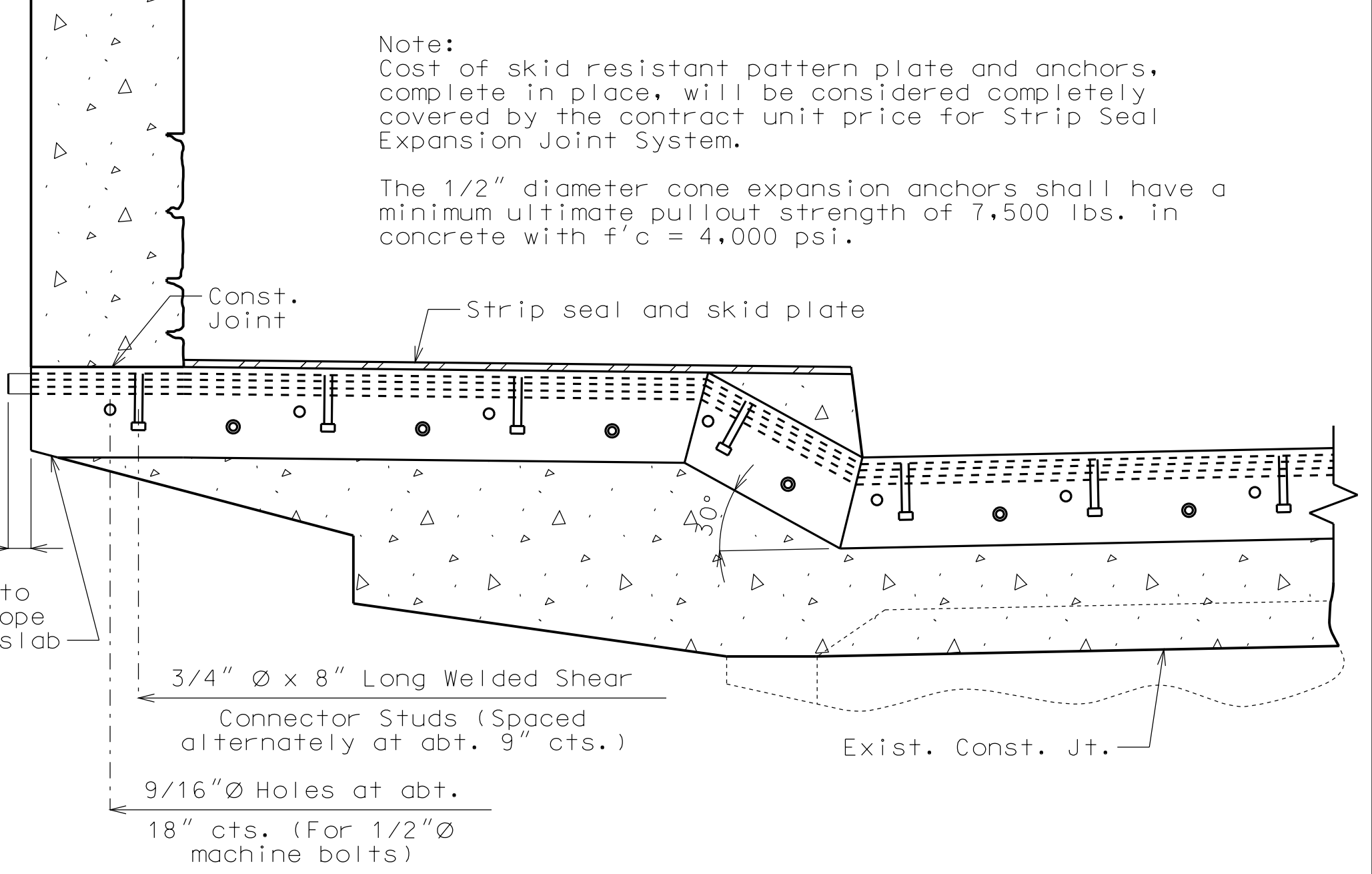

PART SECTION NEAR STRIP SEAL JOINT

GENERAL NOTES:

Expansion joint system shall be fabricated in one section, except for stage construction and when the length is over 50 feet. A complete joint penetration groove welded splice shall be required. Welds shall be ground flush to provide a smooth surface. The expansion joint system shall be fabricated and installed to the crown and grade of the roadway.

The strip seal gland shall be installed in joints in one continuous piece without field splices. Factory splicing will be permitted for joints in excess of 53 feet.

Structural steel for the expansion joint system shall be ASTM A709 Grade 36 except the steel armor may be ASTM A709 Grade 50W. Anchors for the expansion joint system shall be in accordance with Sec 1037. Strip seal expansion joint system shall be in accordance with Sec 717.

Structural steel for the expansion joint system shall be coated with a minimum of two coats of inorganic zinc primer (5 mils minimum) or galvanized in accordance with ASTM A123. Anchors need not be protected from overspray.

Plan dimensions are based on installation at 60°F. The expansion gap and other dimensions shall be increased or decreased 3/16" for each 10° fall or rise in temperature at installation.

Concrete shall be forced under and around steel armor and anchors. Proper consolidation of the concrete shall be achieved by localized internal vibration.

Longitudinal reinforcing steel shall be placed so that ends shall not be more than ±1" from vertical leg of the steel armor at the expansion joint system.

Top of backwall for End Bent No. 9 shall be formed to the crown and grade of the roadway. Backwall above upper construction joint shall not be poured until the superstructure slab has been poured in the adjacent span.

All concrete above the upper construction joint in backwall shall be Class B-2.

The contractor shall use one of the qualified resin anchor systems in accordance with Sec 1039.

Cost of furnishing and installing the resin anchor system, complete in place, will be considered completely covered by the contract unit price for Reinforced Concrete Slab Overlay.

The minimum embedment depth in concrete with f'c = 4,000 psi for the resin anchor system shall be that required to meet the minimum ultimate pullout strength in accordance with Sec 1039 but shall not be less than 5".

Measurement of strip seal expansion joint system is to the nearest linear foot for each structure, measured along the front face of backwall from roadway face to roadway face of corral curb.

Note: Cost of skid resistant pattern plate and anchors, complete in place, will be considered completely covered by the contract unit price for Strip Seal Expansion Joint System.

The 1/2" diameter cone expansion anchors shall have a minimum ultimate pullout strength of 7,500 lbs. in concrete with f'c = 4,000 psi.

"THIS MEDIA SHOULD NOT BE CONSIDERED A CERTIFIED DOCUMENT."

DATE PREPARED 1/22/2014	
ROUTE I-670	STATE MO
DISTRICT BR	SHEET NO. 4
COUNTY JACKSON	
JOB NO. J412023	
CONTRACT ID.	
PROJECT NO.	
BRIDGE NO. A08073	

DESCRIPTION	DATE

MISSOURI HIGHWAYS AND TRANSPORTATION COMMISSION

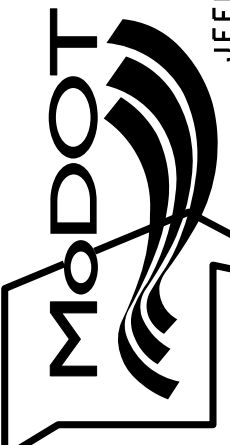

105 WEST CAPITOL
JEFFERSON CITY, MO 65102
1-888-ASK-MODOT (1-888-273-6636)

IF A SEAL IS PRESENT ON THIS SHEET IT HAS BEEN ELECTRONICALLY SEALED AND DATED.

"THIS MEDIA SHOULD NOT BE CONSIDERED A CERTIFIED DOCUMENT."

DATE PREPARED
1/22/2014

ROUTE STATE
I-670 MO

DISTRICT SHEET NO.
BR 5

COUNTY
JACKSON

JOB NO.
J412023

CONTRACT ID.

PROJECT NO.

BRIDGE NO.
A08073

DESCRIPTION

DATE

MISSOURI HIGHWAYS AND TRANSPORTATION COMMISSION

105 WEST CAPITOL JEFFERSON CITY, MO 65102

1-888-ASK-MODOT (1-888-275-6636)

IF A SEAL IS PRESENT ON THIS SHEET IT HAS BEEN ELECTRONICALLY SEALED AND DATED.

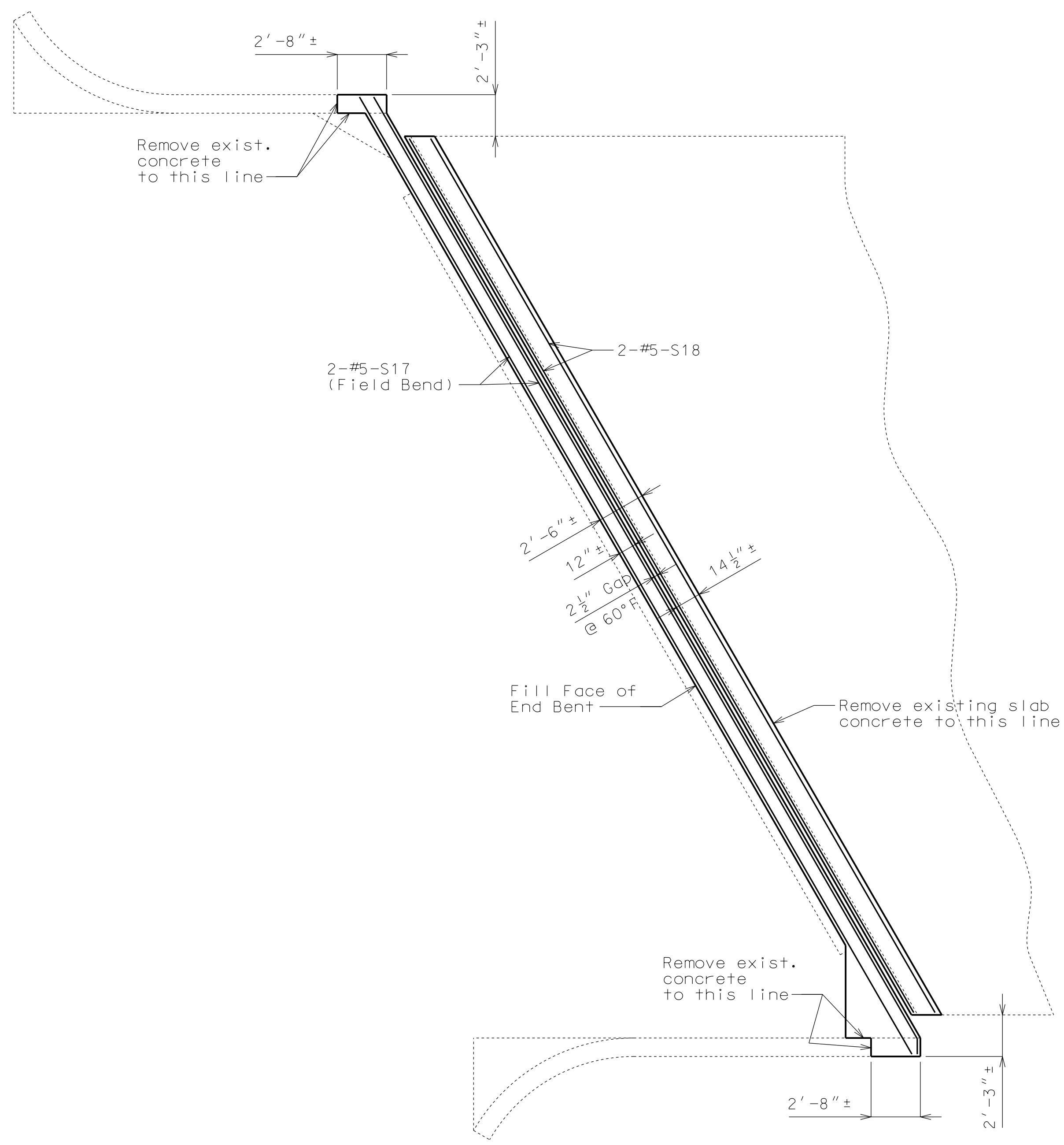

PART PLAN OF SLAB AT END BENT NO. 1 SHOWING REINFORCEMENT

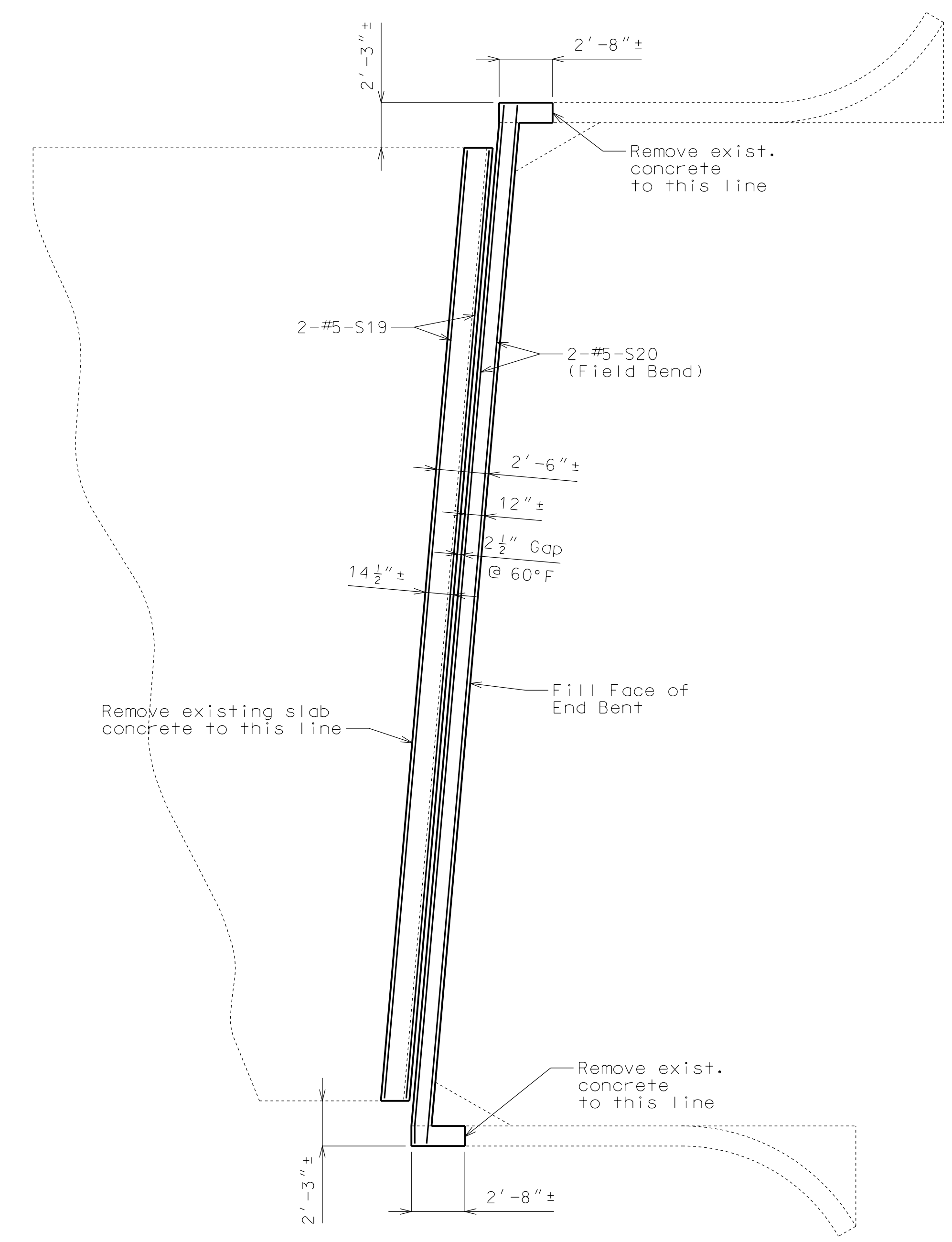

PART PLAN OF SLAB AT END BENT NO. 9 SHOWING REINFORCEMENT

Notes:
Shift #5-S bars where necessary to clear shear connector studs on the expansion joint system.
Payment for slab and backwall concrete, complete-in-place, for expansion joint replacement will be considered completely covered by the contract unit price for Reinforced Concrete Slab Overlay.
Payment for furnishing and installing reinforcing steel in slab and backwall for expansion joint replacement will be considered completely covered by the contract unit price for Reinforced Concrete Slab Overlay.
Cost of removing existing expansion joint, slab and backwall concrete within the limits shown will be considered completely covered by the contract unit price for Removal of Post-tensioned Slab.
For section thru Strip Seal at End Bent No. 1, see Sheet No. 3.
For section thru Strip Seal at End Bent No. 9, see Sheet No. 4.

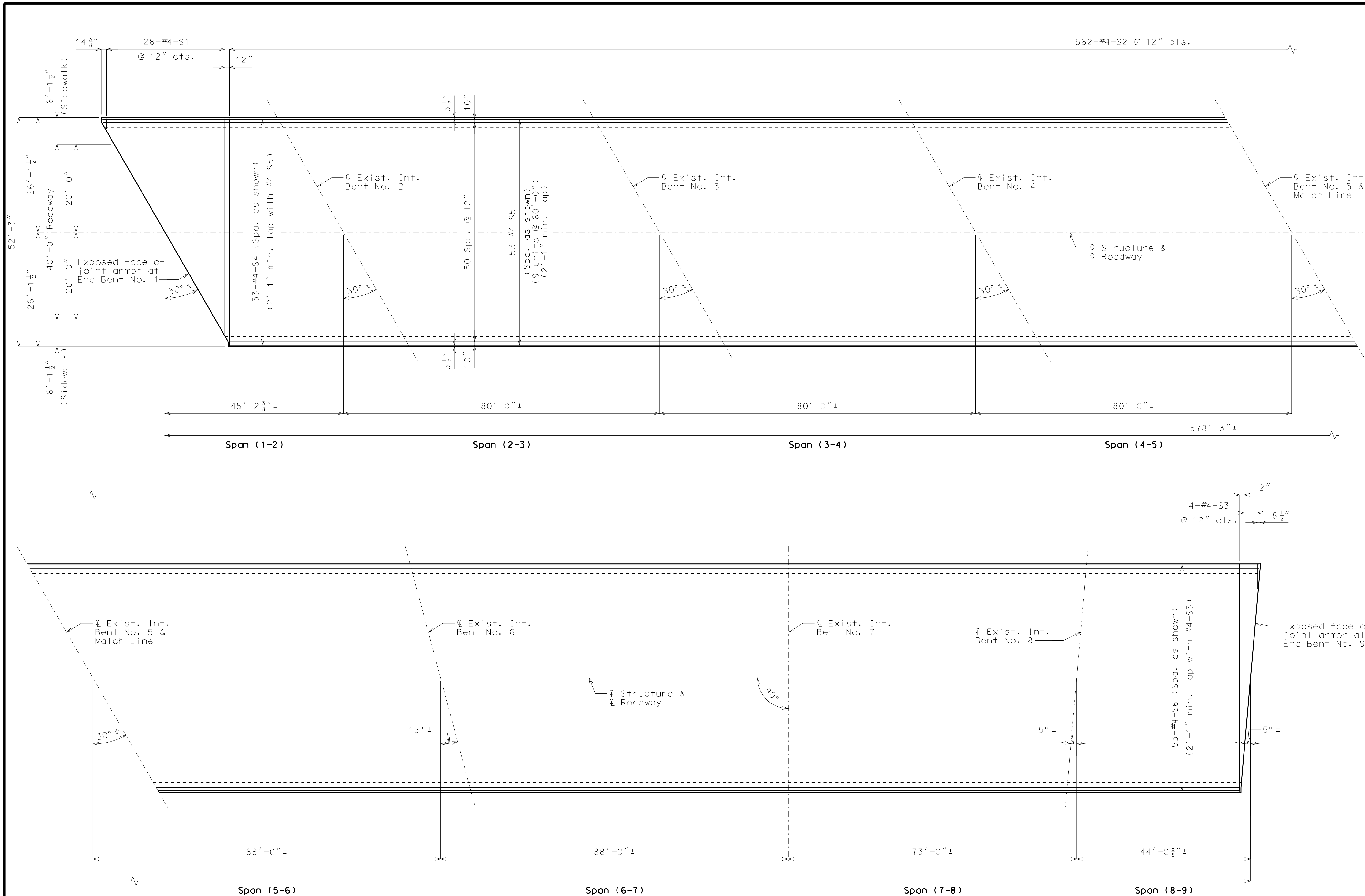

PLAN OF SLAB SHOWING BOTTOM REINFORCEMENT
SLAB DETAILS

Note:
Work this sheet with Sheets No. 7, & 8.

Detailed Dec. 2013
Checked Jan. 2014

Note: This drawing is not to scale. Follow dimensions.

Sheet No. 6 of 19

"THIS MEDIA SHOULD NOT BE CONSIDERED A CERTIFIED DOCUMENT."

DATE PREPARED
1/22/2014

ROUTE STATE
I-670 MO

DISTRICT SHEET NO.
BR 6

COUNTY
JACKSON

JOB NO.
J412023

CONTRACT ID.

PROJECT NO.

BRIDGE NO.
A08073

DESCRIPTION

DATE

DATE

DATE

DATE

DATE

DATE

DATE

DATE

DATE

DATE

DATE

DATE

DATE

DATE

DATE

DATE

DATE

DATE

DATE

DATE

DATE

DATE

DATE

DATE

DATE

DATE

DATE

DATE

DATE

DATE

DATE

DATE

DATE

DATE

DATE

DATE

DATE

DATE

DATE

DATE

DATE

DATE

DATE

DATE

DATE

DATE

DATE

DATE

DATE

DATE

DATE

DATE

IF A SEAL IS PRESENT ON THIS SHEET IT HAS BEEN ELECTRONICALLY SEALED AND DATED.

MISSOURI HIGHWAYS AND TRANSPORTATION
COMMISSION

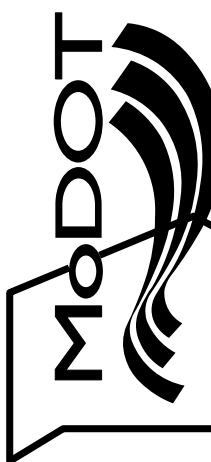

105 WEST CAPITOL
JEFFERSON CITY, MO 65102
1-888-ASK-MODOT (1-888-273-6636)

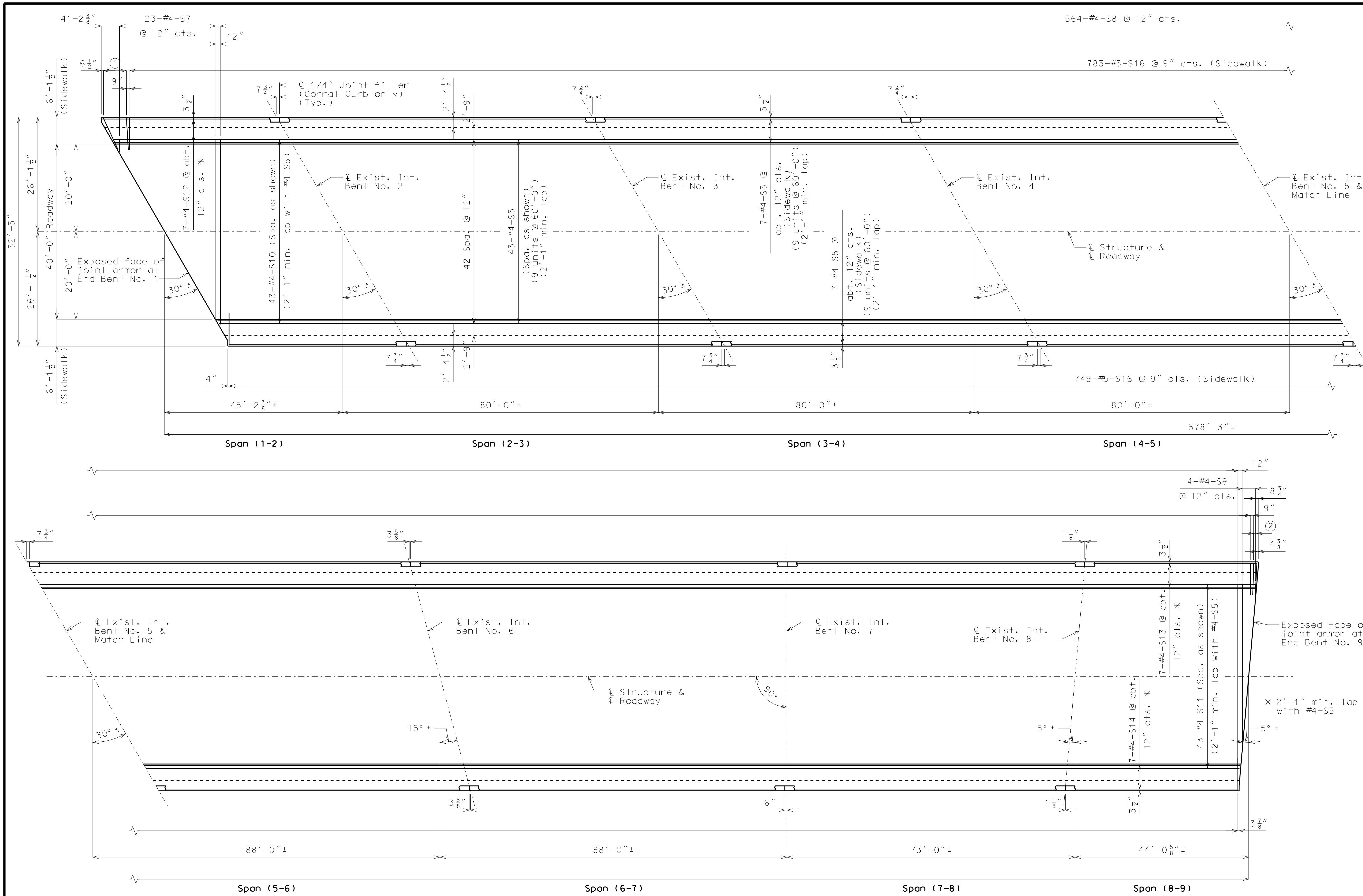

"THIS MEDIA SHOULD NOT BE CONSIDERED A CERTIFIED DOCUMENT."	
DATE PREPARED 1/22/2014	
ROUTE I-670	STATE MO
DISTRICT BR	SHEET NO. 7
COUNTY JACKSON	
JOB NO. J412023	
CONTRACT ID.	
PROJECT NO.	
BRIDGE NO. A08073	
DESCRIPTION	DATE
MISSOURI HIGHWAYS AND TRANSPORTATION COMMISSION	
 105 WEST CAPITOL JEFFERSON CITY, MO 65102 1-888-ASK-MODOT (1-888-275-6636)	

Detailed Dec. 2013
 Checked Jan. 2014

Note:
 Work this sheet with Sheets No. 6, & 8.
 For Details of Corral Curb, see Sheets No. 11, 12, 13 & 14.

PLAN OF SLAB SHOWING TOP REINFORCEMENT
 SLAB DETAILS

- ① 8-#5-S15 Spa. @ 9" cts. along edge of slab
- ② 2-#5-S16 spa. @ 9" cts. along edge of slab

IF A SEAL IS PRESENT ON THIS SHEET IT HAS BEEN ELECTRONICALLY SEALED AND DATED.

"THIS MEDIA SHOULD NOT BE CONSIDERED A CERTIFIED DOCUMENT."

DATE PREPARED
1/22/2014

ROUTE STATE
I-670 MO

DISTRICT SHEET NO.
BR 8

COUNTY
JACKSON

JOB NO.
J412023

CONTRACT ID.

PROJECT NO.

BRIDGE NO.
A08073

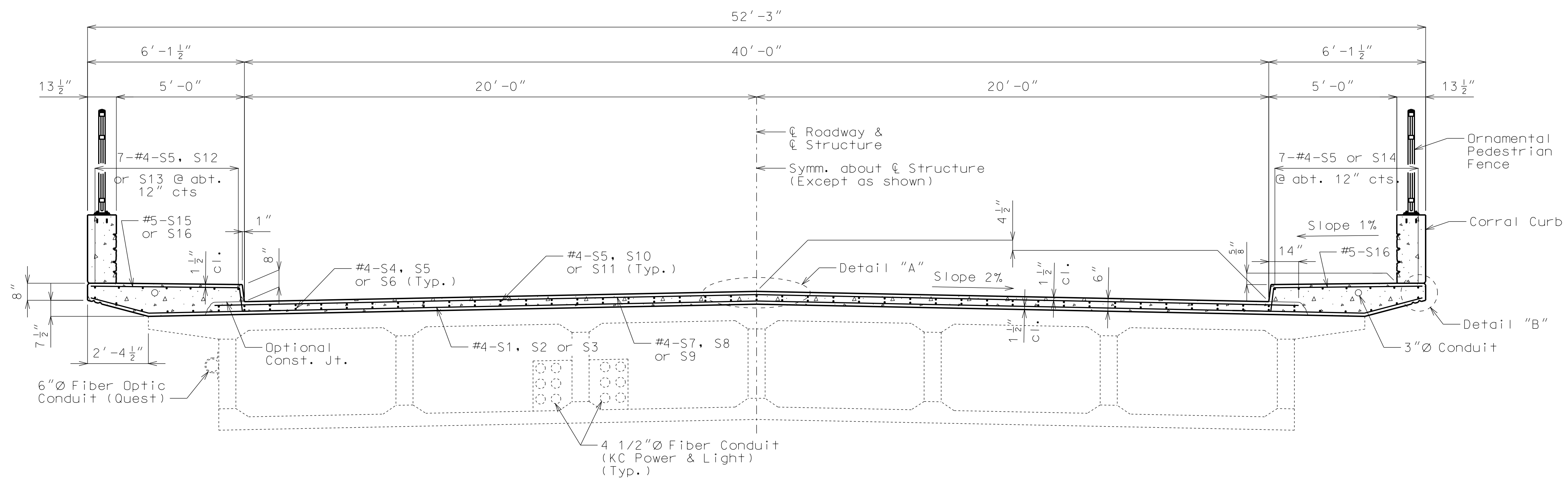

SECTION THRU SLAB SHOWING REINFORCEMENT

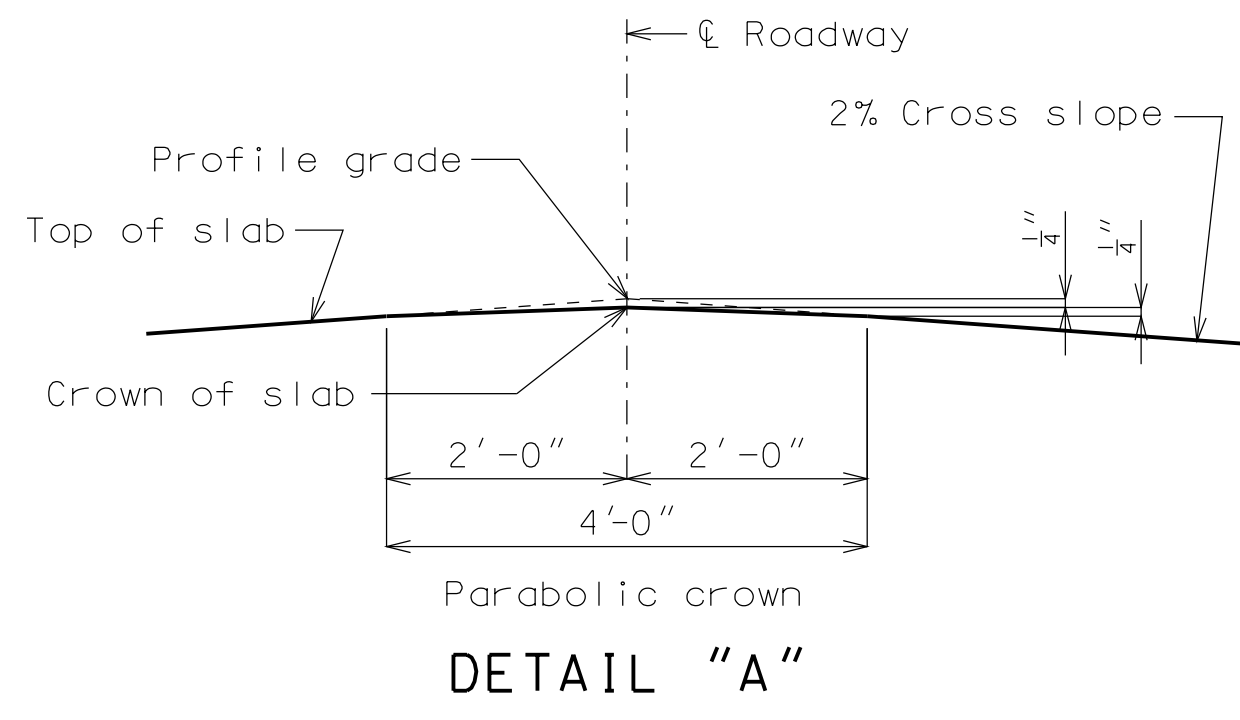

DETAIL "A"

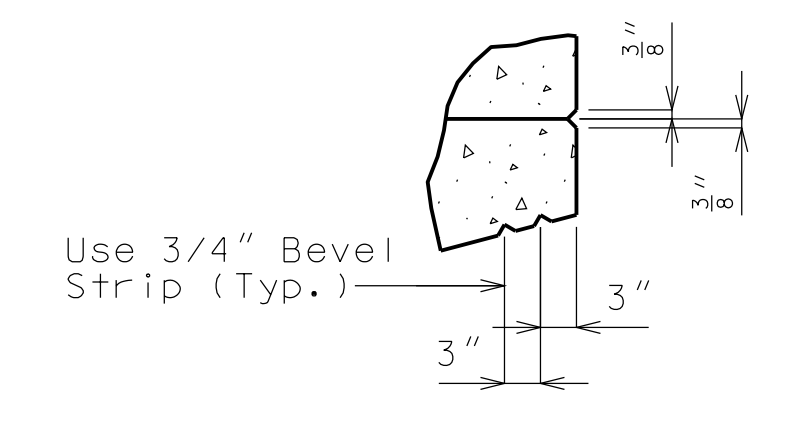

DETAIL "B"

Note:
Work this sheet with Sheets No. 6. & 7.
Slab shall be poured upgrade from end to end at a minimum rate of 25 cu. yd./ hr.
For Details of Corral Curb, see Sheets No. 11, 12, 13 & 14.
For Details of Ornamental Pedestrian Fence, see Sheets No. 9 & 10.

SLAB DETAILS

DATE	DESCRIPTION

MISSOURI HIGHWAYS AND TRANSPORTATION COMMISSION

105 WEST CAPITOL
JEFFERSON CITY, MO 65102
1-888-ASK-MISSOURI (1-888-275-6636)

IF A SEAL IS PRESENT ON THIS SHEET IT HAS BEEN ELECTRONICALLY SEALED AND DATED.

"THIS MEDIA SHOULD NOT BE CONSIDERED A CERTIFIED DOCUMENT."

DATE PREPARED
1/22/2014
ROUTE I-670 STATE MO
DISTRICT BR SHEET NO. 9
COUNTY JACKSON
JOB NO. J412023
CONTRACT ID.
PROJECT NO.
BRIDGE NO. A08073

DESCRIPTION	DATE

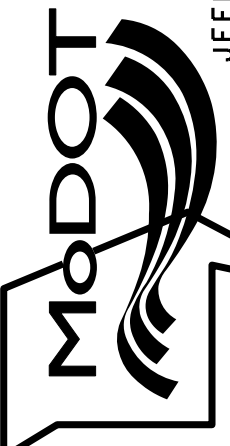
MISSOURI HIGHWAYS AND TRANSPORTATION COMMISSION

 105 WEST CAPITOL
 JEFFERSON CITY, MO 65102
 1-888-ASK-MODOT (1-888-273-6636)

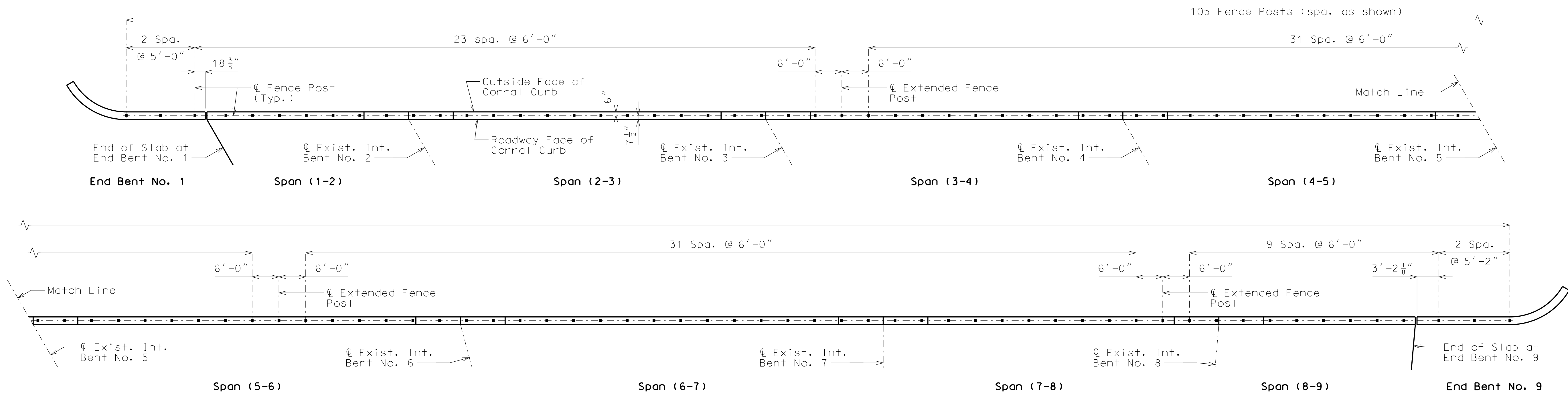
IF A SEAL IS PRESENT ON THIS SHEET IT HAS BEEN ELECTRONICALLY SEALED AND DATED.

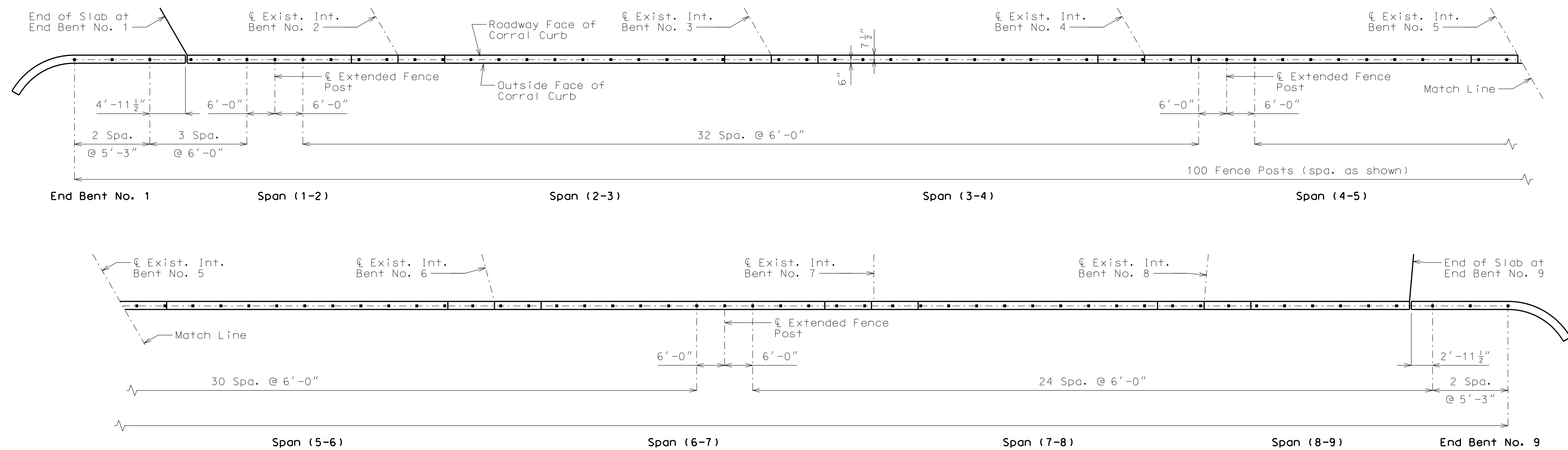

PLAN OF LEFT CORRAL CURB SHOWING FENCE POST SPACING



PLAN OF RIGHT CORRAL CURB SHOWING FENCE POST SPACING

ORNAMENTAL PEDESTRIAN FENCE DETAILS

Notes:
For Ornamental Pedestrian Fence Details, see Sheet No. 10.
For Details of Corral Curb, see Sheets No. 11, 12, 13 & 14.

Notes:
Ornamental pedestrian fencing shall be in accordance with 2010 AASHTO LRFD Bridge Design Specifications and 2010 Interim Revisions. 50 lb/ft and 200 lb loading shall not be applied simultaneously.

Fence shall have a gloss black finish (Federal Standard #17038) System "G" in accordance with Sec 1081.

Base plate shall be ASTM A709, Grade 36.

Dimensions of pedestrian fence are measured horizontally.

Measurement of pedestrian fence will be made to the nearest linear foot along centerline fence.

Payment for furnishing and erecting the fence complete in place with U-Bolts, washers and reinforcing bars will be considered completely covered by the contract unit price for Ornamental Pedestrian Fence.

All fence posts shall be vertical.

Mortar shall be placed under the post base plates in accordance with Sec 1066.

Expansion joints shall be placed in the horizontal pieces at not more than 30 feet centers and at all joint filler locations in the sidewalk with a minimum gap of 1/4" @ 60 degree F.

Contractor shall submit complete detailed shop drawings in accordance with Sec 1080.

The contractor shall have the ornamental pedestrian fencing manufacturer submit structural design computations signed and sealed by a registered professional engineer in the State of Missouri.

All materials used in fabrication and construction of the ornamental pedestrian fencing shall be in accordance with the manufacturer's specifications, except as modified in the contract documents.

Ornamental pedestrian fencing system shall be supplied by only one of the manufacturers. Fencing system shall include all components except the anchor bolts and #4 bars welded to the anchor bolts. The assembly of the pickets to the rails and the rails to the posts shall be the same as the style mentioned for the manufacturer.

Ameristar Fence Products, Inc.
1555 N. Mingo
Tulsa, OK. 74116
(800) 321-8724
www.ameristarfence.com

Iron Eagle Industries, Inc.
1256 Cardiff Blvd.
Mississauga, Ontario Canada L5S1R1
(905) 670-2558
www.ironeagleind.com

Style: AEGIS II Majestic

Style: Silver Eagle II

Betafence USA
3309 S.W. Interstate 45
Ennis, TX. 75119
(888) 650-4766
www.betafenceusa.com

Merchants Metals
6575 Romiss Court
St. Louis, MO 63134
(800) 293-3363
www.merchantsmetals.com

Style: UpGrade-I Landmark

Style: Guardsman Monroe

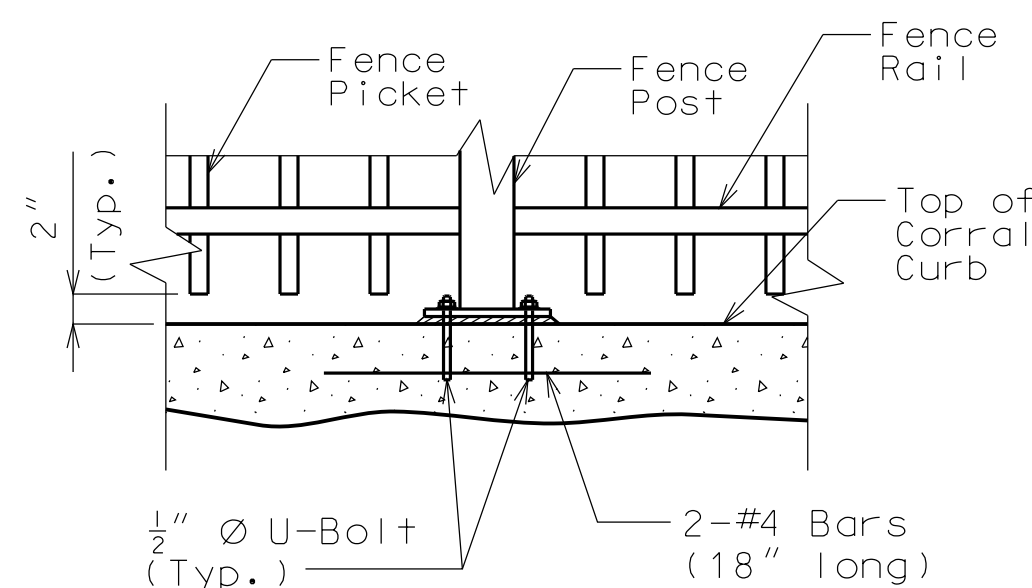

SECTION B-B AT SUPPORT

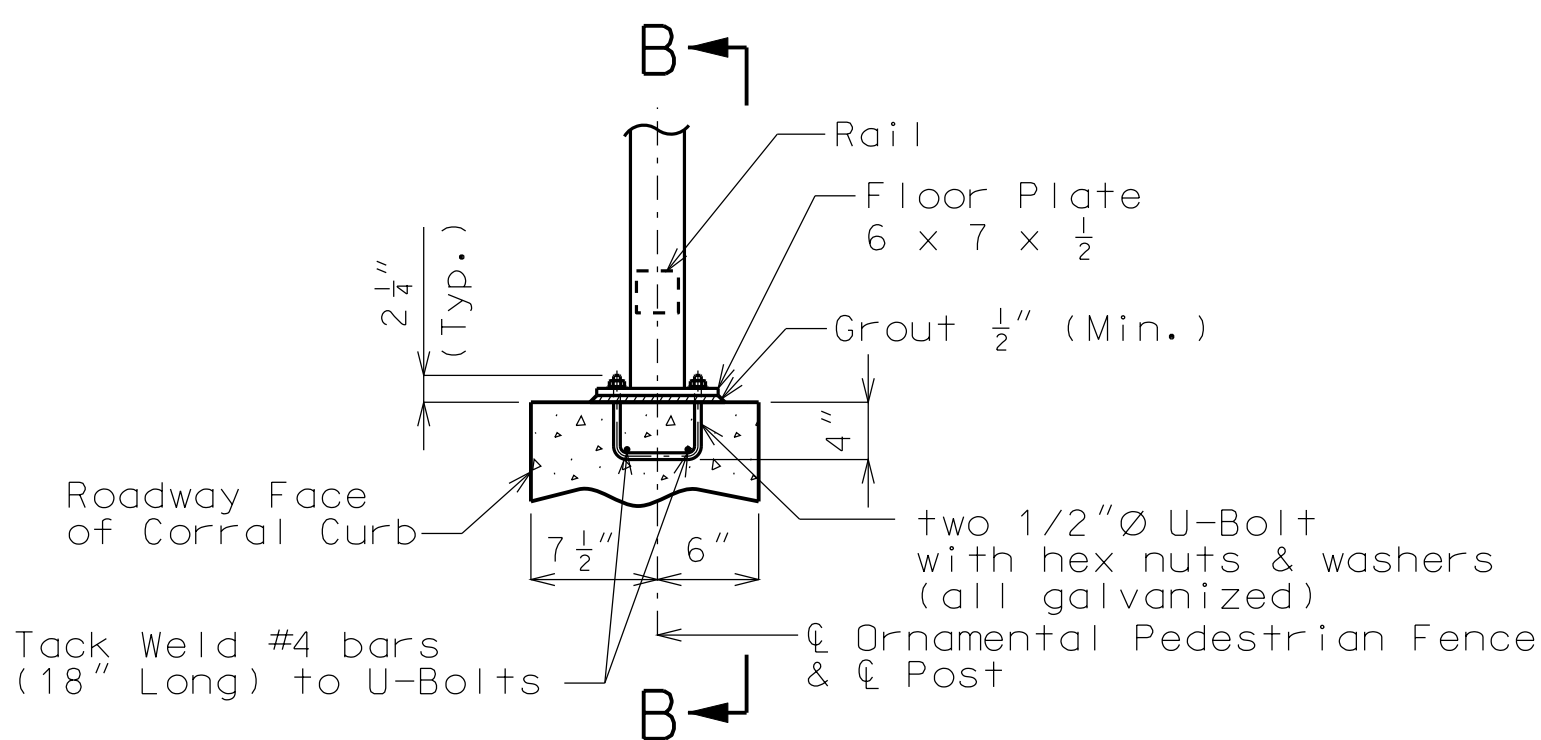

SECTION A-A AT FENCE SUPPORT

Note: Reinforcement not shown for clarity.

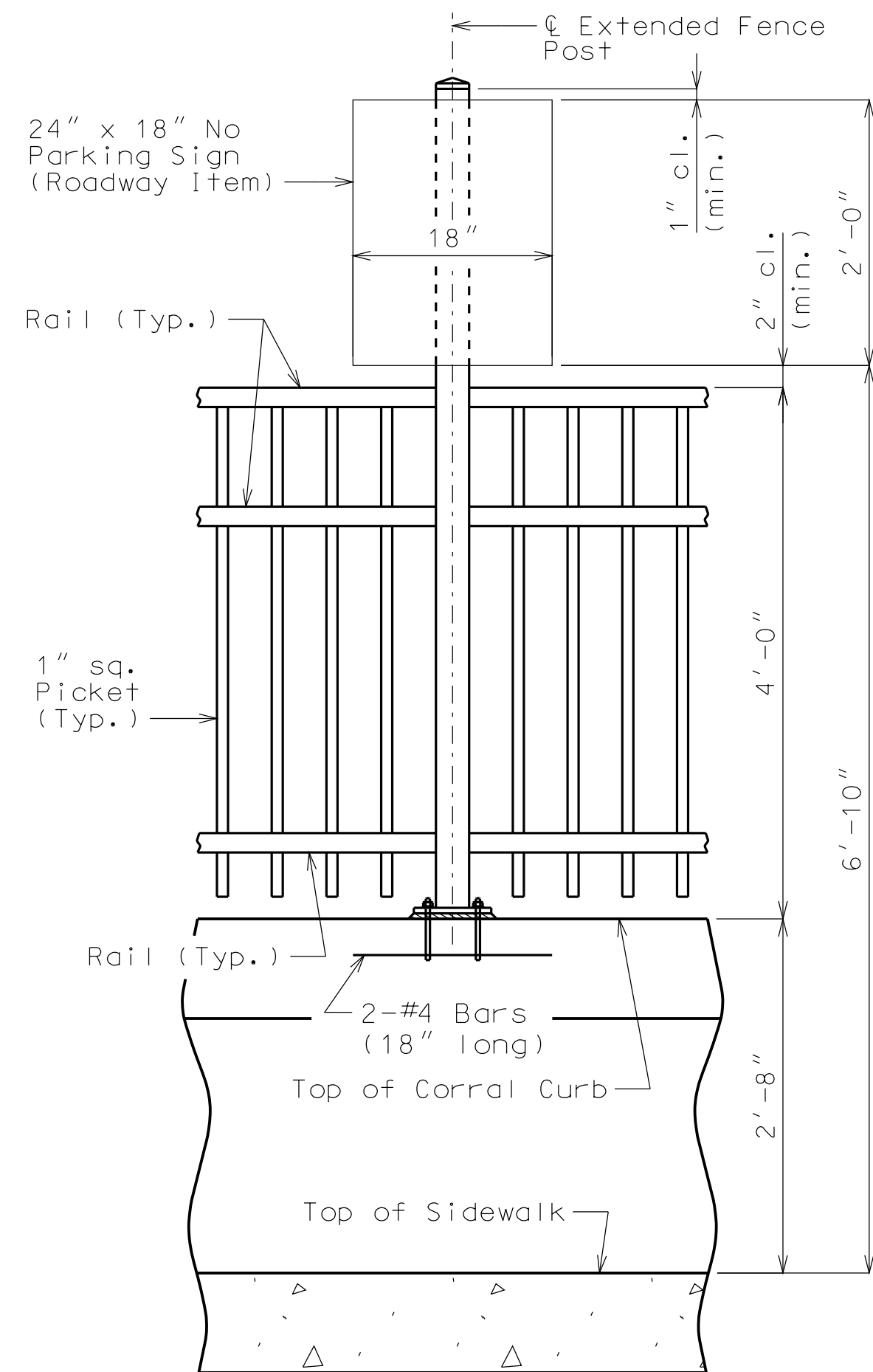

PART ELEVATION SHOWING EXTENDED FENCE POST

Form Liner Detail not shown for clarity.

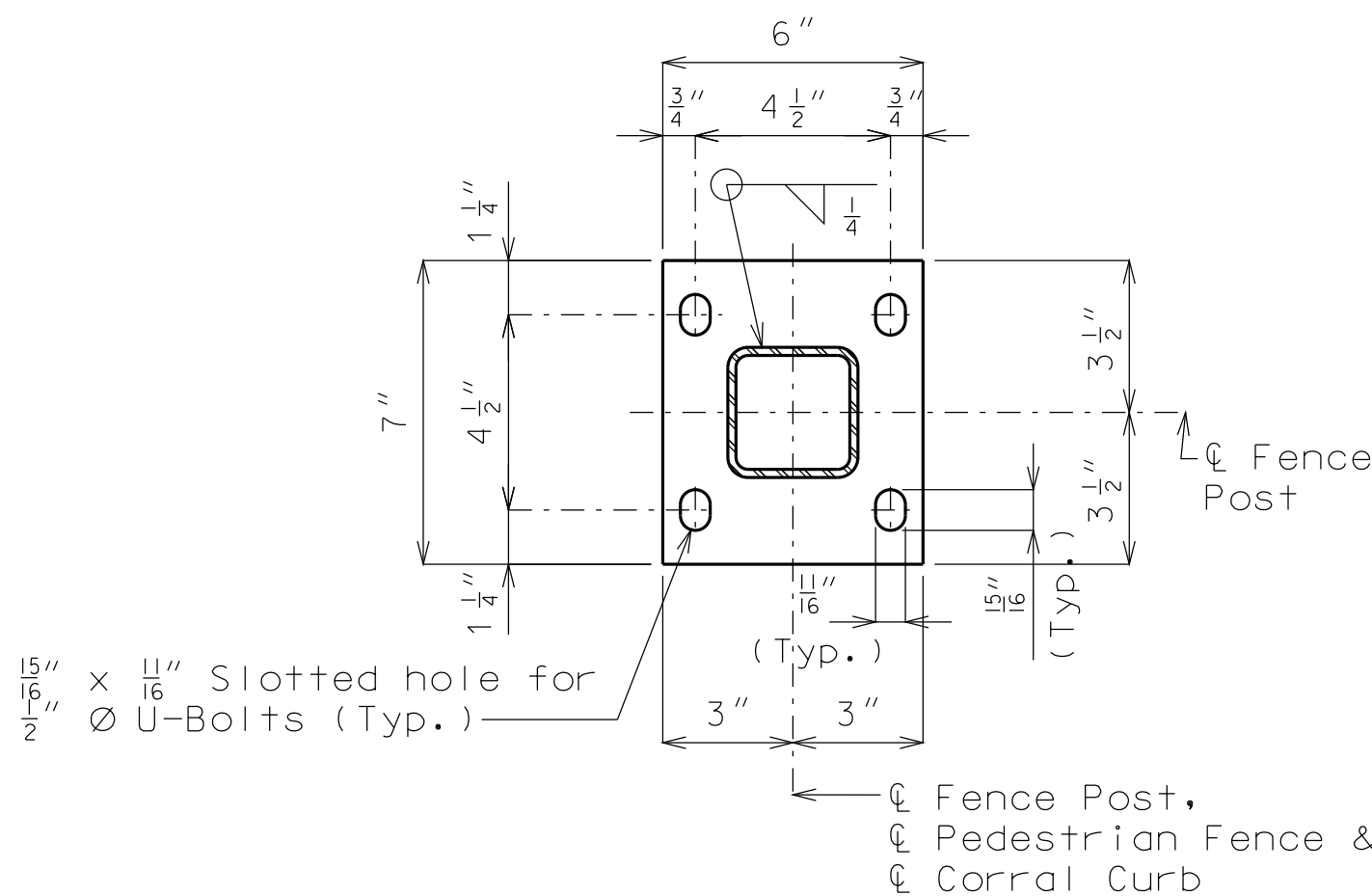

PLAN OF FLOOR PLATE

ORNAMENTAL PEDESTRIAN FENCE DETAILS

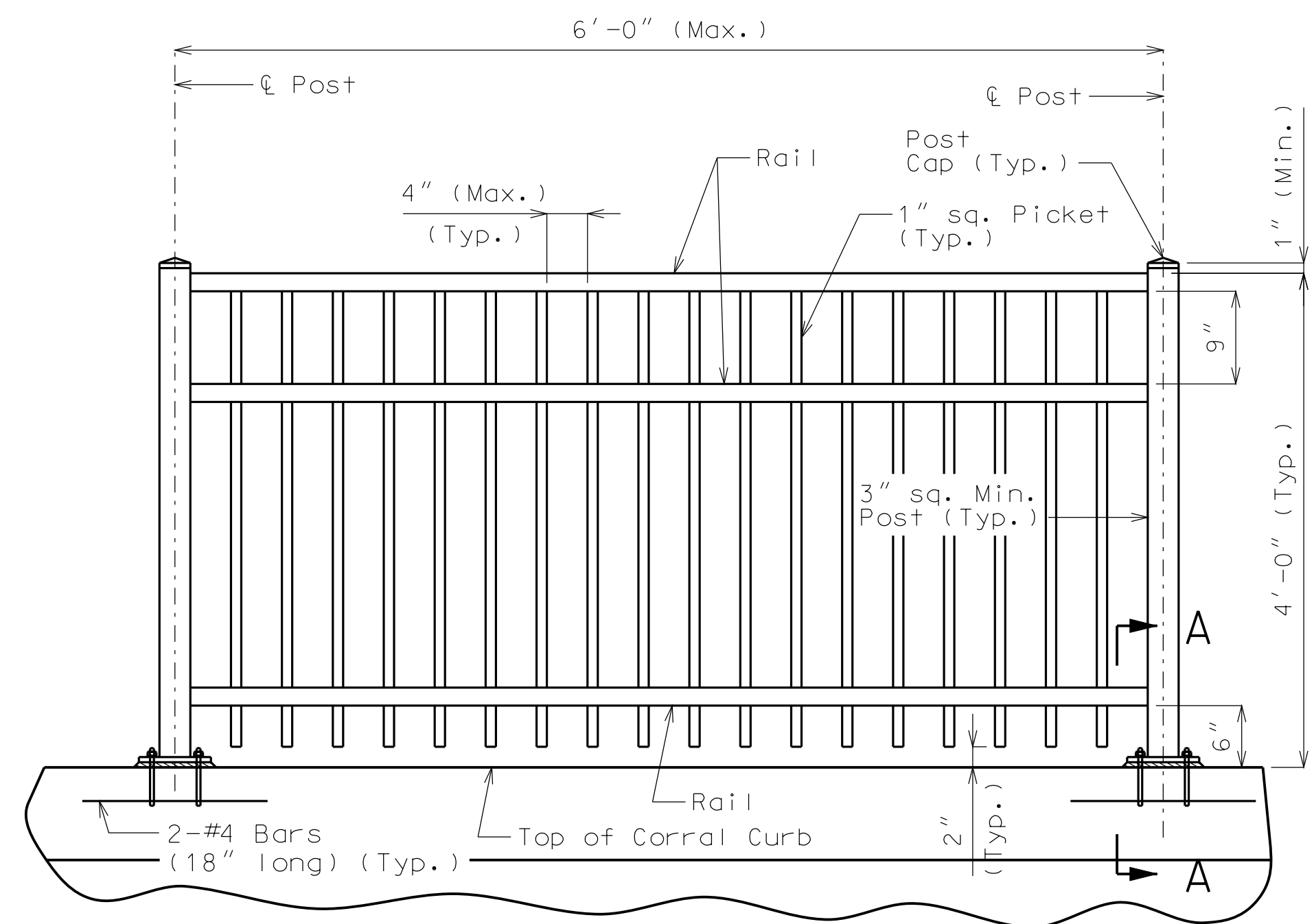

TYPICAL PART ELEVATION

Adjacent panels and Form Liner Detail not shown for clarity.

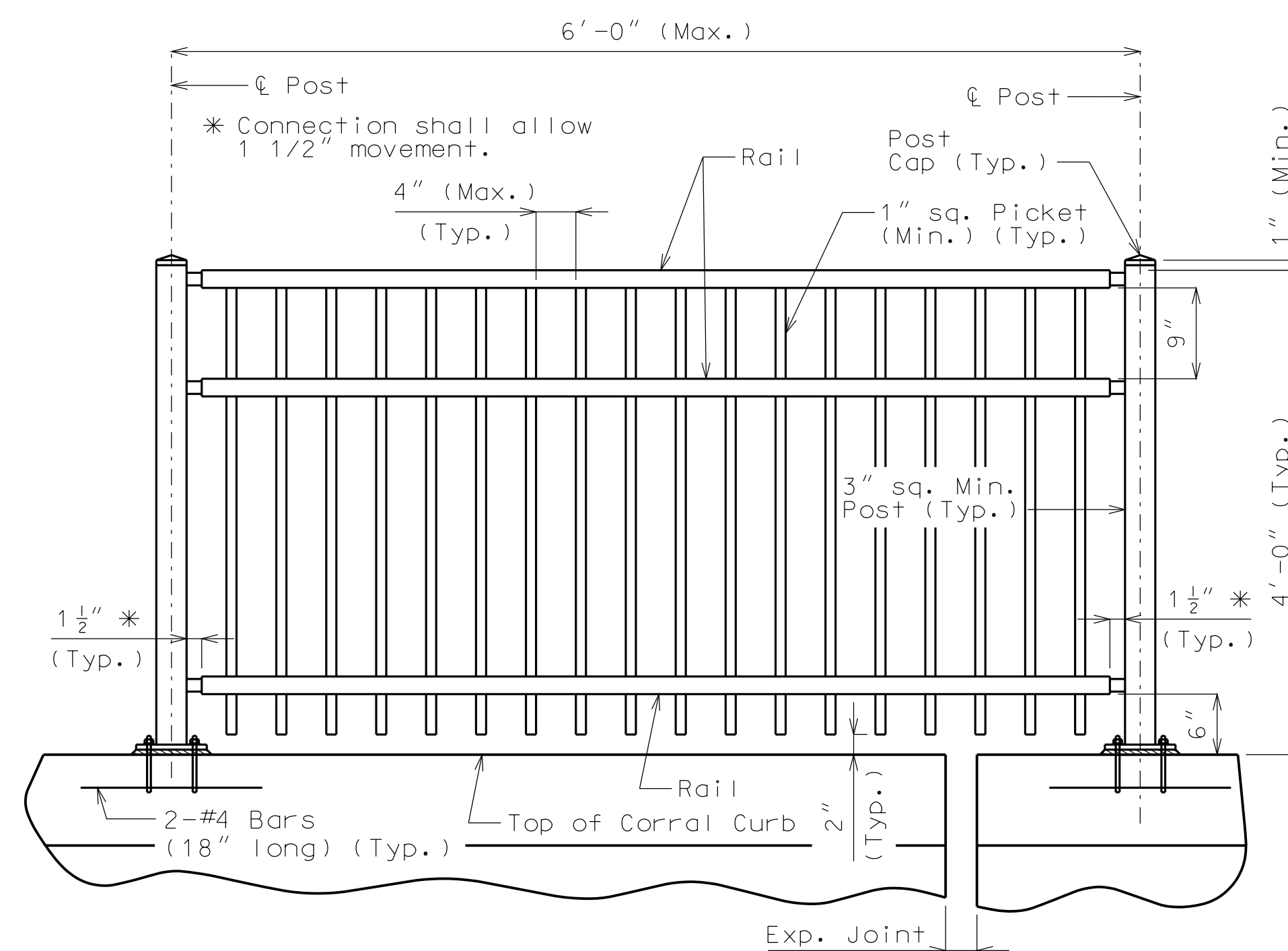

TYPICAL PART ELEVATION AT EXPANSION JOINT SHOWING EXPANSION PANEL

Adjacent panels and Form Liner Detail not shown for clarity.

Notes:
For Part Plans of Corral Curb Showing Fence Post Spacing, see Sheet No. 9.
For Details of Corral Curb, see Sheets No. 11, 12, 13 & 14.

"THIS MEDIA SHOULD NOT BE CONSIDERED A CERTIFIED DOCUMENT."

DATE PREPARED
1/22/2014

ROUTE I-670 STATE MO

DISTRICT BR SHEET NO. 10

COUNTY JACKSON

JOB NO. J412023

CONTRACT ID.

PROJECT NO.

BRIDGE NO. A08073

DESCRIPTION

DATE

MISSOURI HIGHWAYS AND TRANSPORTATION COMMISSION

105 WEST CAPITOL JEFFERSON CITY, MO 65102

1-888-ASK-MODOT (1-888-273-6636)

MoDOT

IF A SEAL IS PRESENT ON THIS SHEET IT HAS BEEN ELECTRONICALLY SEALED AND DATED.

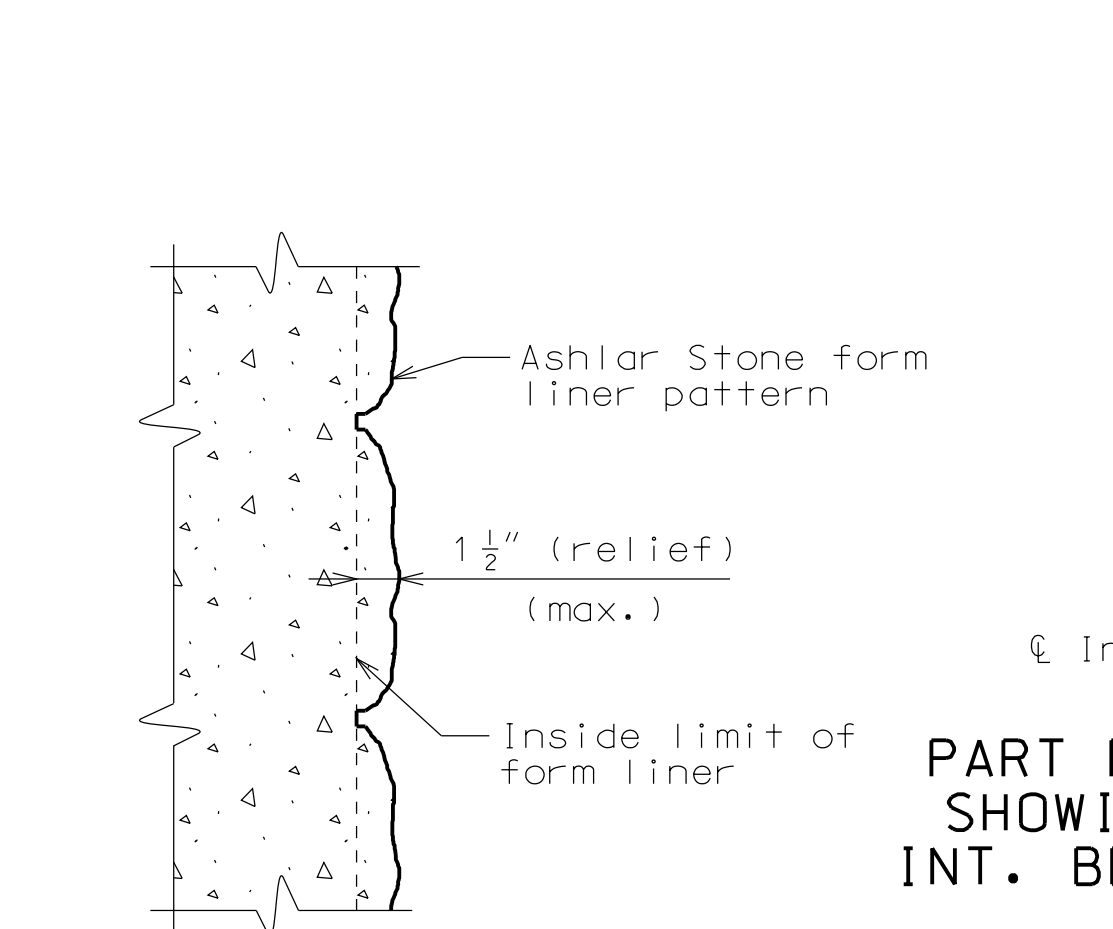
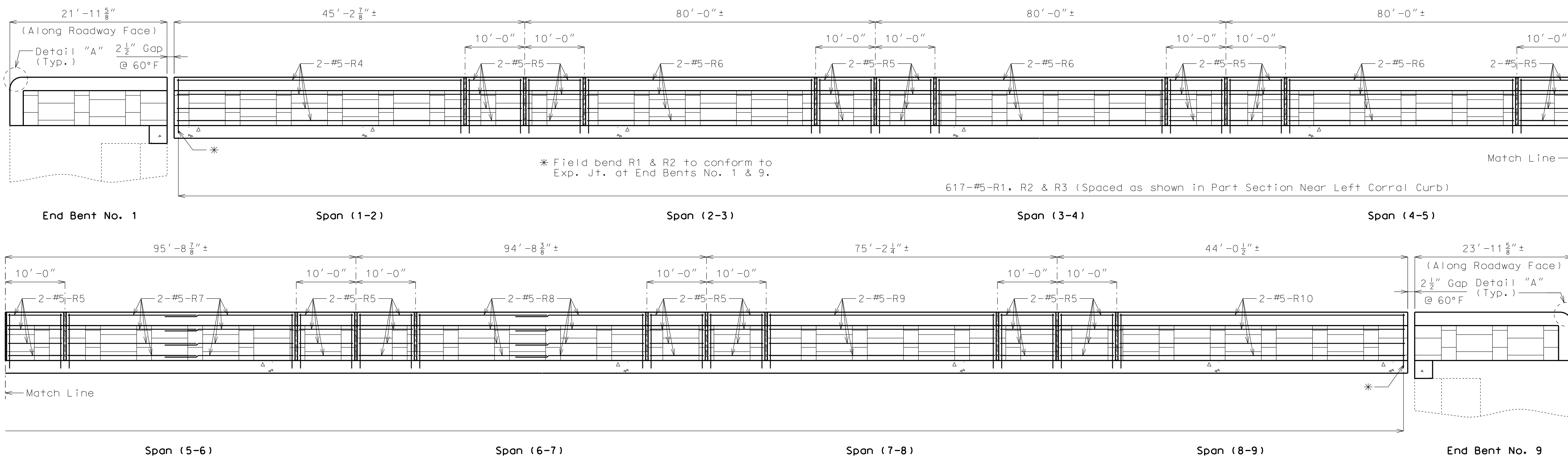

TYPICAL PART SECTION AT FORMLINER

Notes:
The following is a list of form liner manufacturers and types which may be used. All form liner patterns depth of relief shall vary up to 1 1/2". The height of any single 'stone' shall be 15" maximum.

- Scott System, Inc.: Form liner pattern #167 "Ashlar Stone"
- Fitzgerald formliners: Form liner pattern #16986 "Ashlar Stone"
- Greenstreak: Form liner pattern #330 "Ashlar Stone"
- Dayton Superior/Symons: Form liner pattern #1515 "Ashlar Stone"

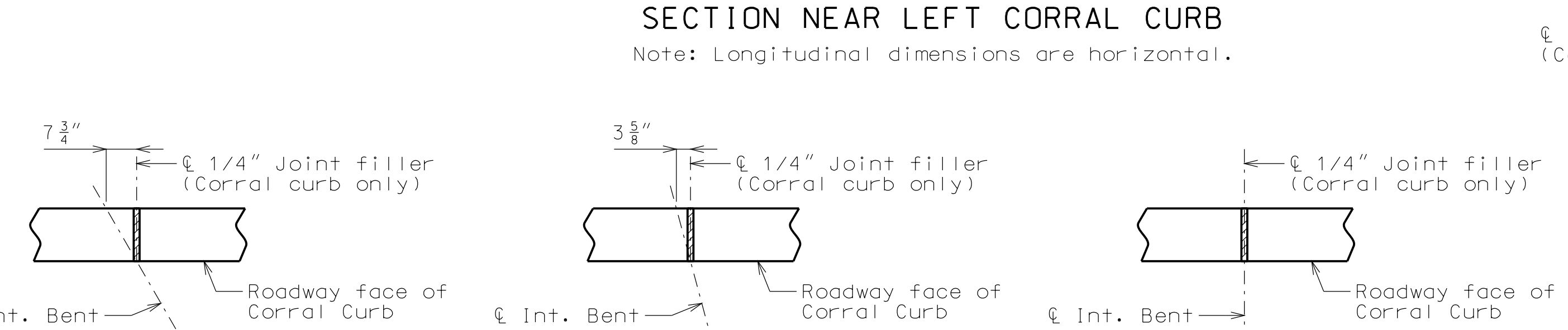

SECTION NEAR LEFT CORRAL CURB
Note: Longitudinal dimensions are horizontal.

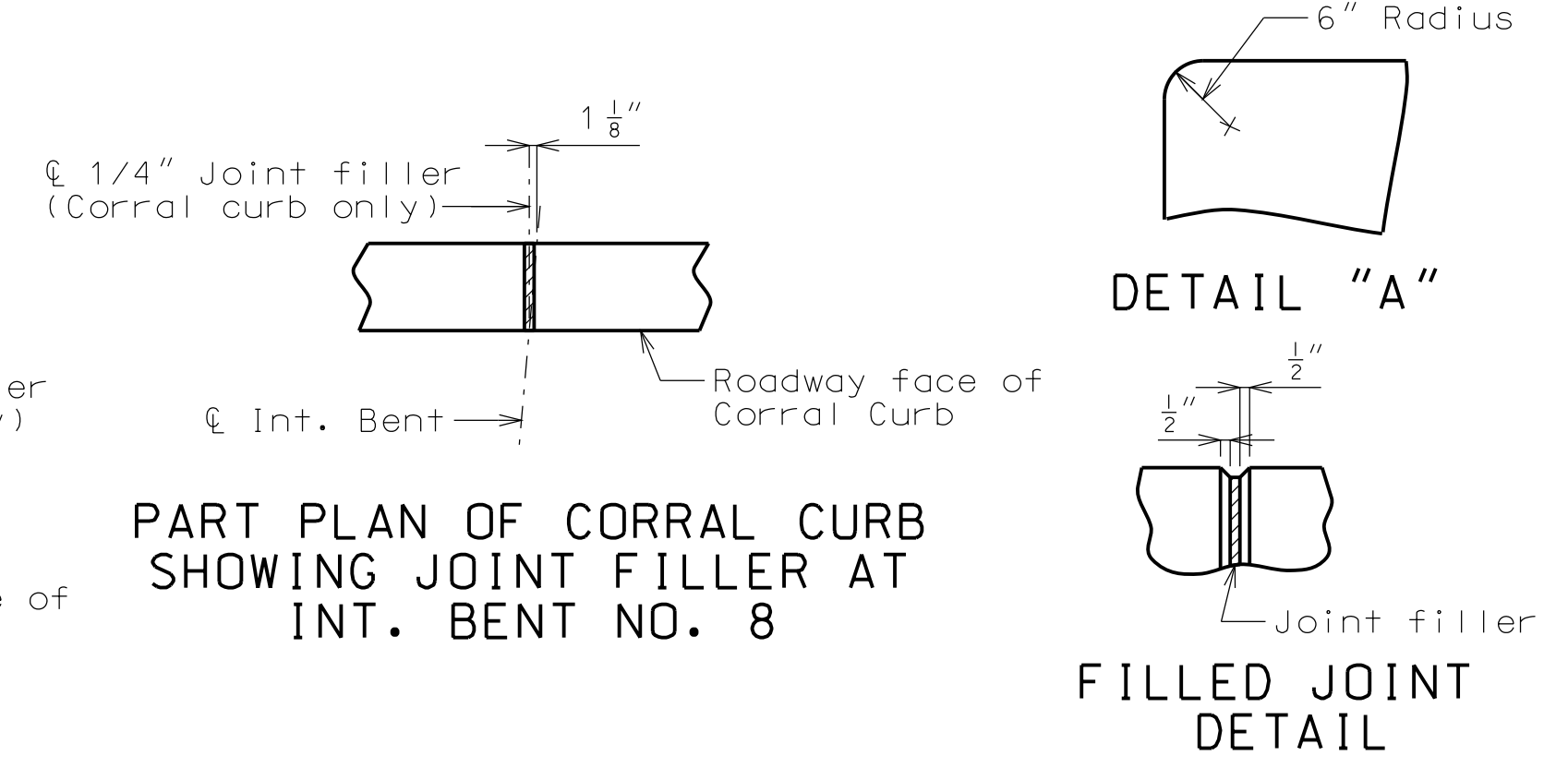

PART PLAN OF CORRAL CURB SHOWING JOINT FILLER AT INT. BENT NO. 8

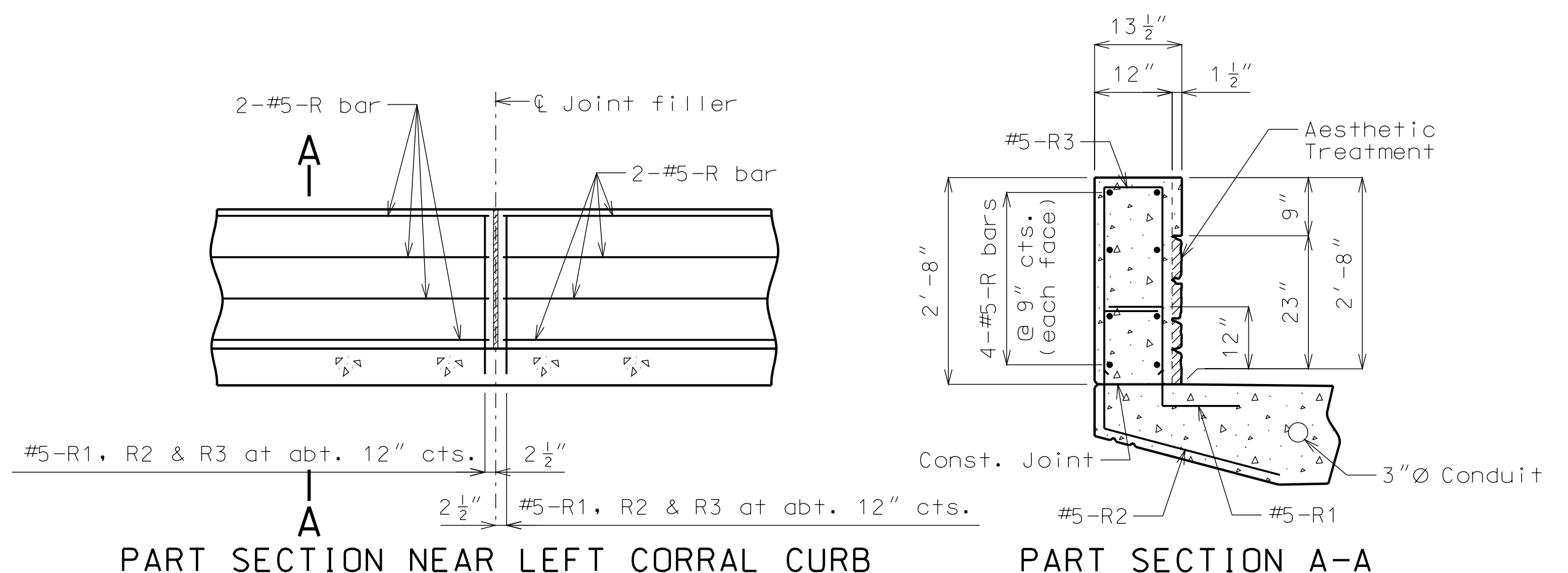

PART SECTION NEAR LEFT CORRAL CURB
PART SECTION A-A

DETAILS OF LEFT CORRAL CURB

Notes:
Top of corral curb shall be built parallel to grade with corral curb joints (except at end bents) normal to grade.
All exposed edges of corral curb shall have either a 1/2" radius or a 3/8" bevel, unless otherwise noted.
Payment for all concrete and reinforcement, complete in place, will be considered completely covered by the contract unit price for corral curb per linear foot.
Concrete in the corral curb shall be Class B-1.
Measurement of corral curb is to the nearest linear foot for each structure, measured along the outside top of slab from end of wing to end of wing.
For details of corral curb at End Bents not shown, see Sheet No. 13.
For Ornamental Fence Post spacing, see Sheet No. 9.
For Details of Ornamental Fencing, see Sheet No. 10.
Use a minimum lap of 2'-11" for #5 horizontal corral curb bars.
The cross-sectional area above the slab = 2.77 sq. ft.
See Special Provisions for form liner specifications.

"THIS MEDIA SHOULD NOT BE CONSIDERED A CERTIFIED DOCUMENT."

DATE PREPARED 1/22/2014	
ROUTE I-670	STATE MO
DISTRICT BR	SHEET NO. 11
COUNTY JACKSON	
JOB NO. J412023	
CONTRACT ID.	
PROJECT NO.	
BRIDGE NO. A08073	

DESCRIPTION	DATE

MISSOURI HIGHWAYS AND TRANSPORTATION COMMISSION

105 WEST CAPITOL
JEFFERSON CITY, MO 65102
1-888-ASK-MODOT (1-888-275-6636)

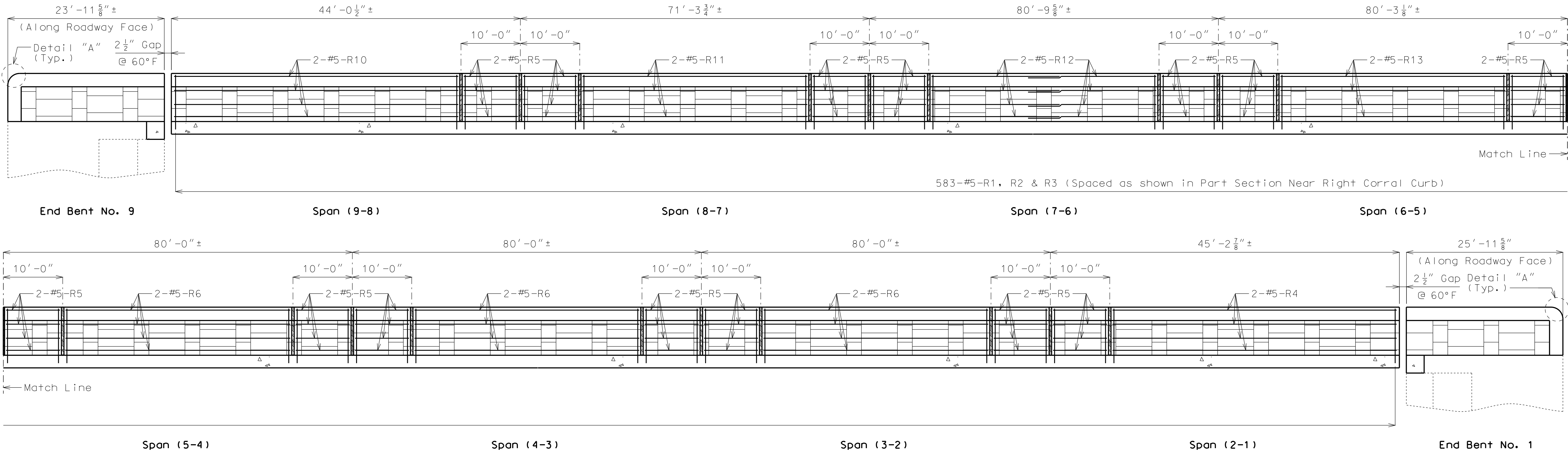

SECTION NEAR RIGHT CORRAL CURB

Note: Longitudinal dimensions are horizontal.

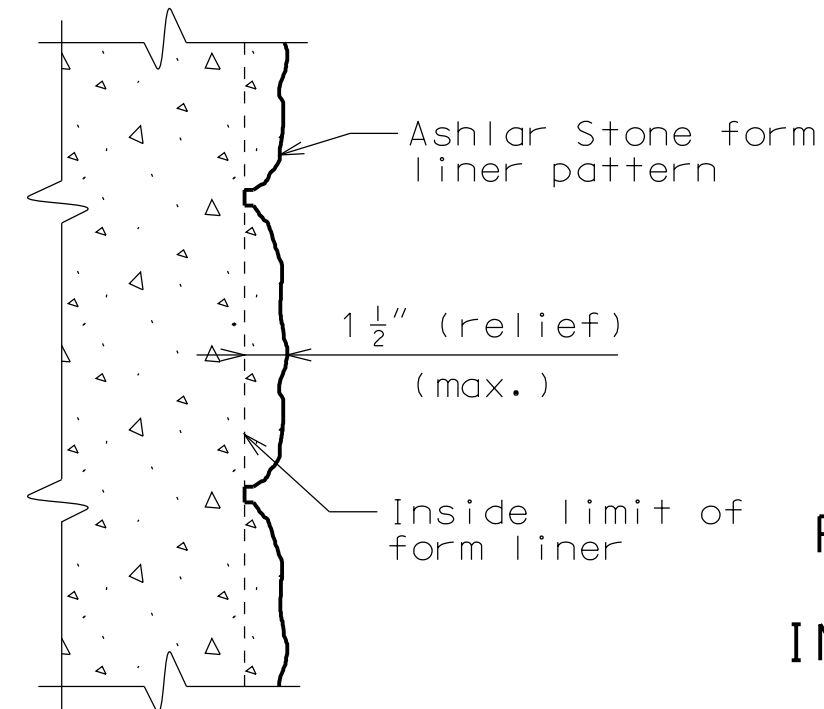

TYPICAL PART SECTION AT FORMLINER

- Notes:
The following is a list of form liner manufacturers and types which may be used. All form liner patterns' depth of relief shall vary up to 1 1/2". The height of any single 'stone' shall be 15" maximum.
- Scott System, Inc.: Form liner pattern #167 "Ashlar Stone"
 - Fitzgerald formliners: Form liner pattern #16986 "Ashlar Stone"
 - Greenstreak: Form liner pattern #330 "Ashlar Stone"
 - Dayton Superior/Symons: Form liner pattern #1515 "Ashlar Stone"

PART PLAN OF CORRAL CURB SHOWING JOINT FILLER AT INT. BENTS NO. 2, 3, 4 & 5

PART PLAN OF CORRAL CURB SHOWING JOINT FILLER AT INT. BENT NO. 6

PART PLAN OF CORRAL CURB SHOWING JOINT FILLER AT INT. BENT NO. 7

PART PLAN OF CORRAL CURB SHOWING JOINT FILLER AT INT. BENT NO. 8

DETAIL "A" FILLED JOINT DETAIL

- Notes:
Top of corral curb shall be built parallel to grade with corral curb joints (except at end bents) normal to grade.
All exposed edges of corral curb shall have either a 1/2" radius or a 3/8" bevel, unless otherwise noted.
Payment for all concrete and reinforcement, complete in place, will be considered completely covered by the contract unit price for corral curb per linear foot.
Concrete in the corral curb shall be Class B-1.
Measurement of corral curb is to the nearest linear foot for each structure, measured along the outside top of slab from end of wing to end of wing.
For details of corral curb at End Bents not shown, see Sheet No. 14.
For Ornamental Fence Post spacing, see Sheet No. 9.
For Details of Ornamental Fencing, see Sheet No. 10.
Use a minimum lap of 2'-11" for #5 horizontal corral curb bars.
The cross-sectional area above the slab = 2.77 sq. ft.
See Special Provisions for form liner specifications.

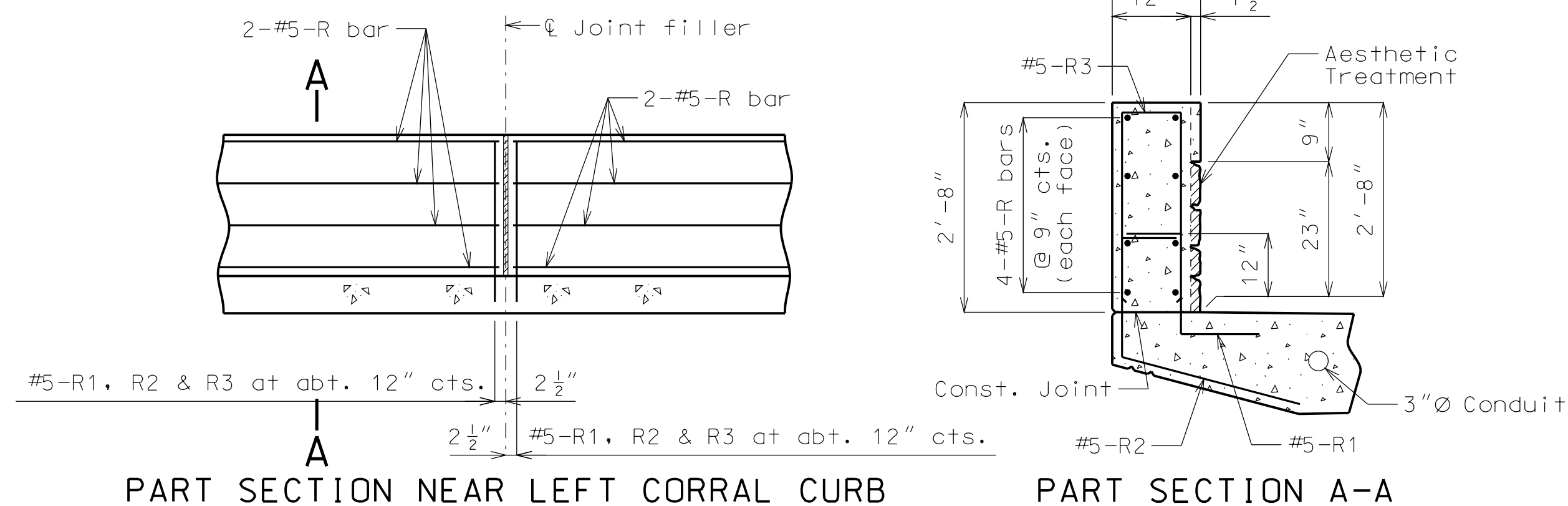

PART SECTION NEAR LEFT CORRAL CURB

PART SECTION A-A

DETAILS OF RIGHT CORRAL CURB

"THIS MEDIA SHOULD NOT BE CONSIDERED A CERTIFIED DOCUMENT."

DATE PREPARED 1/22/2014	
ROUTE I-670	STATE MO
DISTRICT BR	SHEET NO. 12
COUNTY JACKSON	
JOB NO. J412023	
CONTRACT ID.	

PROJECT NO.
BRIDGE NO. A08073

DESCRIPTION	DATE

MISSOURI HIGHWAYS AND TRANSPORTATION COMMISSION

105 WEST CAPITOL
JEFFERSON CITY, MO 65102
1-888-ASK-MODOT (1-888-275-6636)

IF A SEAL IS PRESENT ON THIS SHEET IT HAS BEEN ELECTRONICALLY SEALED AND DATED.

"THIS MEDIA SHOULD NOT BE CONSIDERED A CERTIFIED DOCUMENT."

DATE PREPARED
1/22/2014

ROUTE I-670 STATE MO

DISTRICT BR SHEET NO. 13

COUNTY JACKSON

JOB NO. J412023

CONTRACT ID.

PROJECT NO.

BRIDGE NO. A08073

DESCRIPTION

DATE	DESCRIPTION

DATE	DESCRIPTION

MISSOURI HIGHWAYS AND TRANSPORTATION COMMISSION

105 WEST CAPITOL
JEFFERSON CITY, MO 65102
1-888-ASK-MODOT (1-888-275-6636)

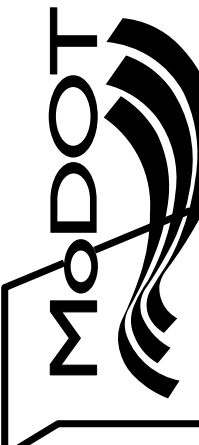

IF A SEAL IS PRESENT ON THIS SHEET IT HAS BEEN ELECTRONICALLY SEALED AND DATED.

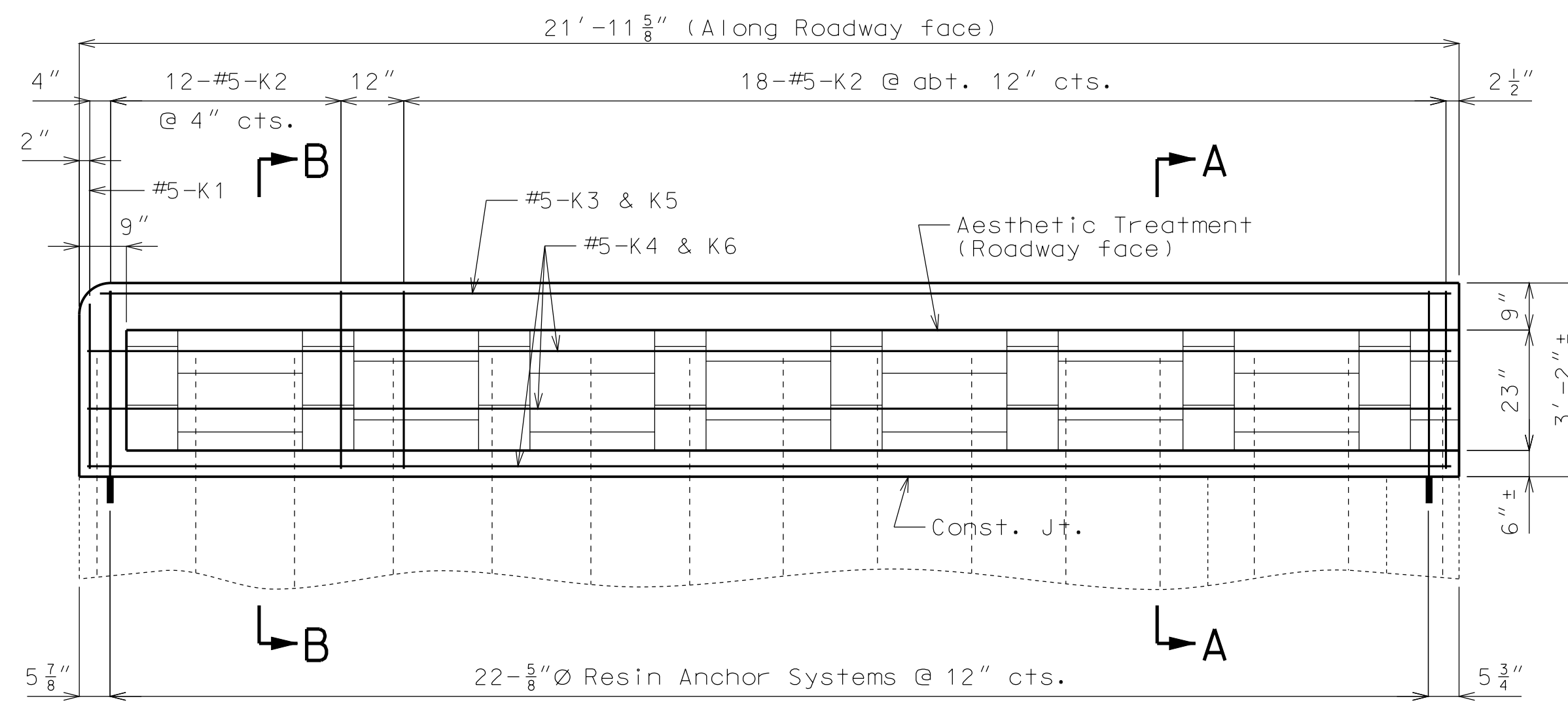

DEVELOPED ELEVATION

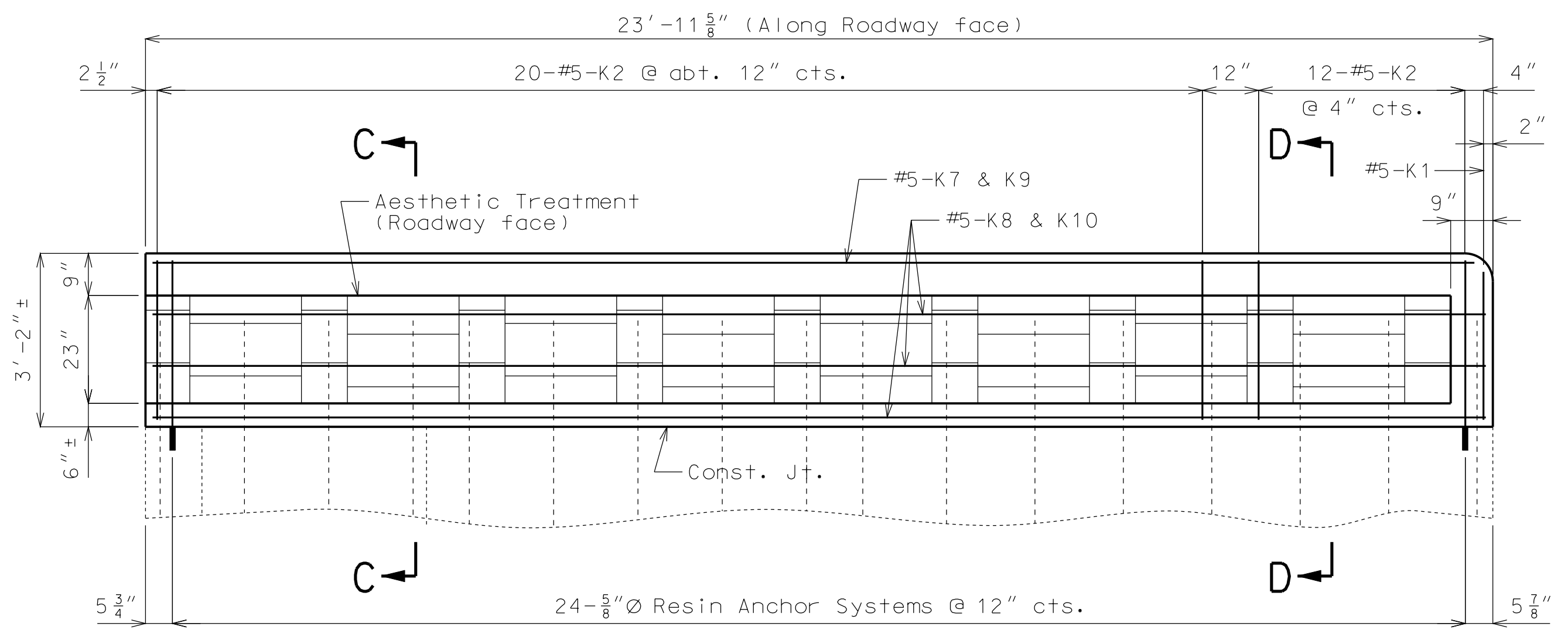

DEVELOPED ELEVATION

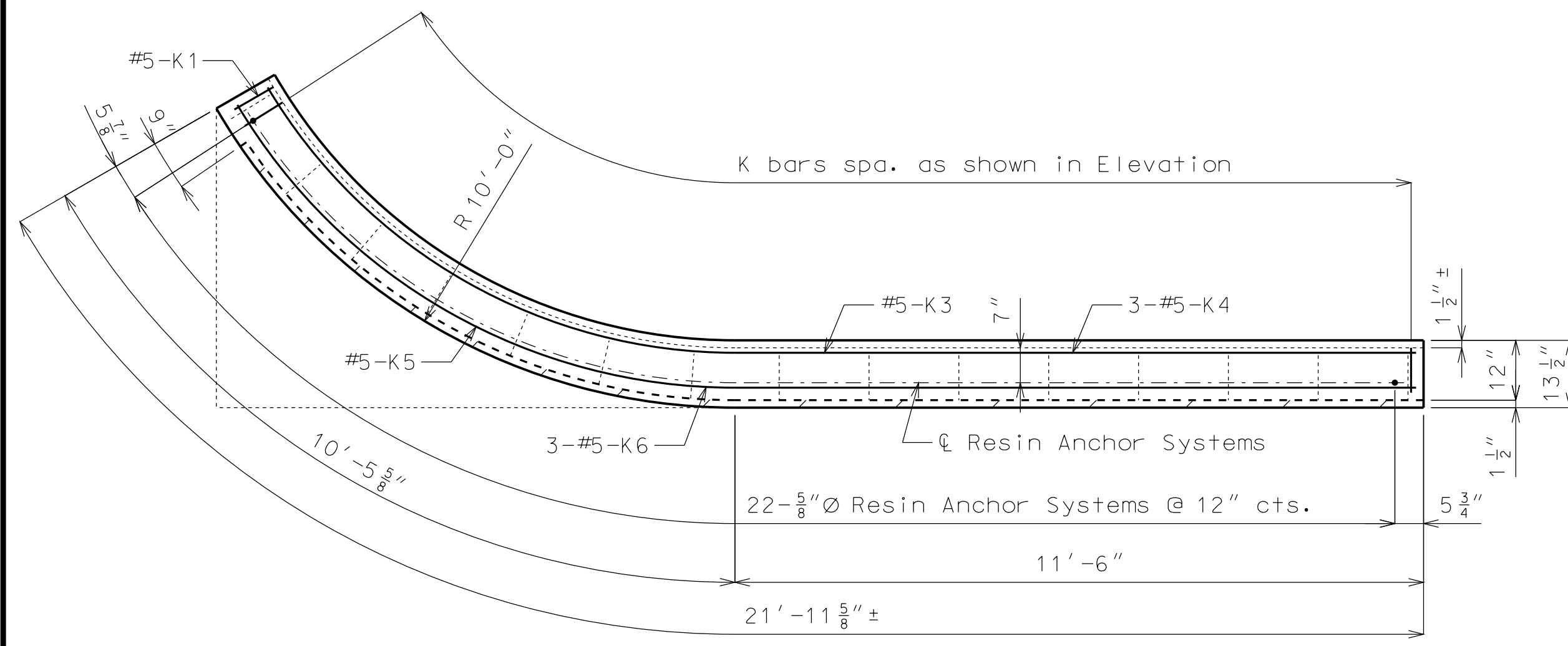

PLAN
END BENT NO. 1

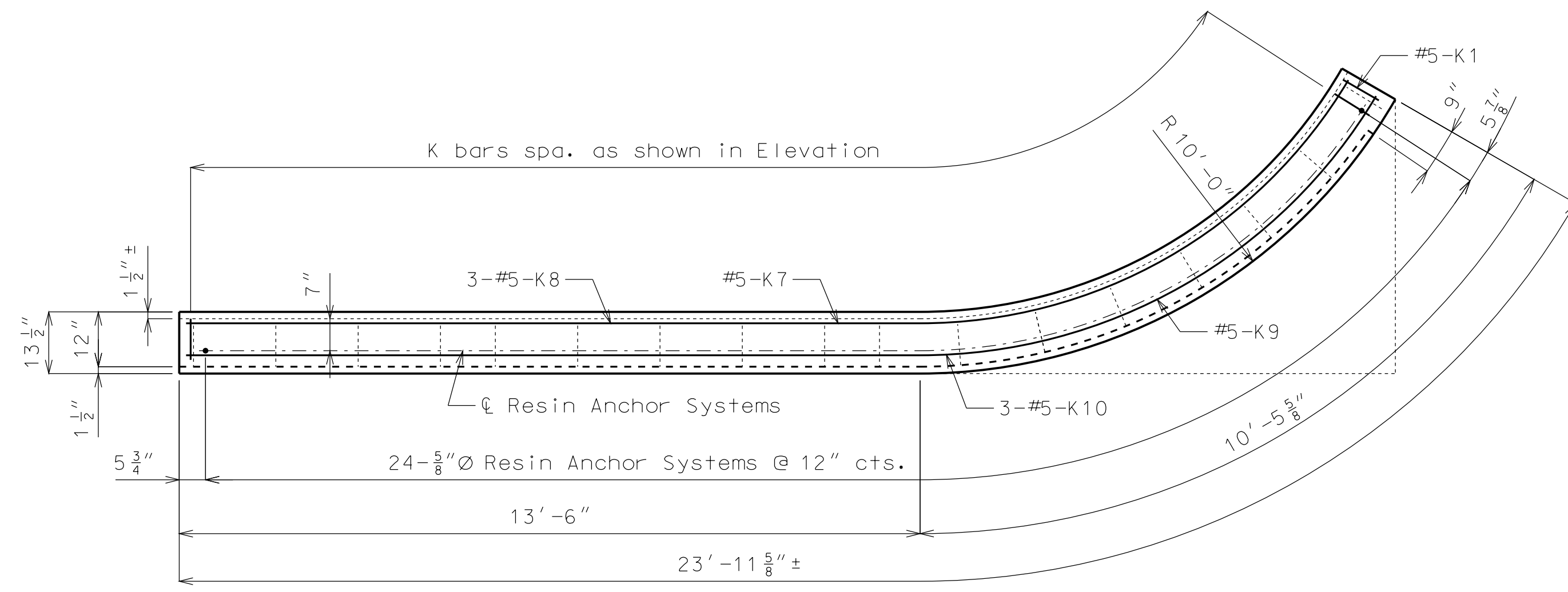

PLAN
END BENT NO. 9

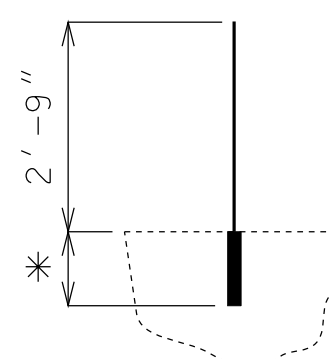

* Manufacturer's recommendation
 Total Req'd = 46 for Left Corral Curb and End Bents
 Total Length = 2'-9" + embedment

DETAIL OF RESIN ANCHOR SYSTEM

Resin Anchor Notes:
 The contractor shall use one of the qualified resin anchor systems in accordance with Sec 1039.

Cost of furnishing and installing the resin anchor system, complete in place, will be considered completely covered by the contract unit price for Reinforced Concrete Slab Overlay.

The minimum embedment depth in concrete with f'c = 4,000 psi for the resin anchor system shall be that required to meet the minimum ultimate pullout strength in accordance with Sec 1039 but shall not be less than 5".

An epoxy coated #5 Grade 60 reinforcing bar shall be substituted for the 5/8"Ø threaded rod.

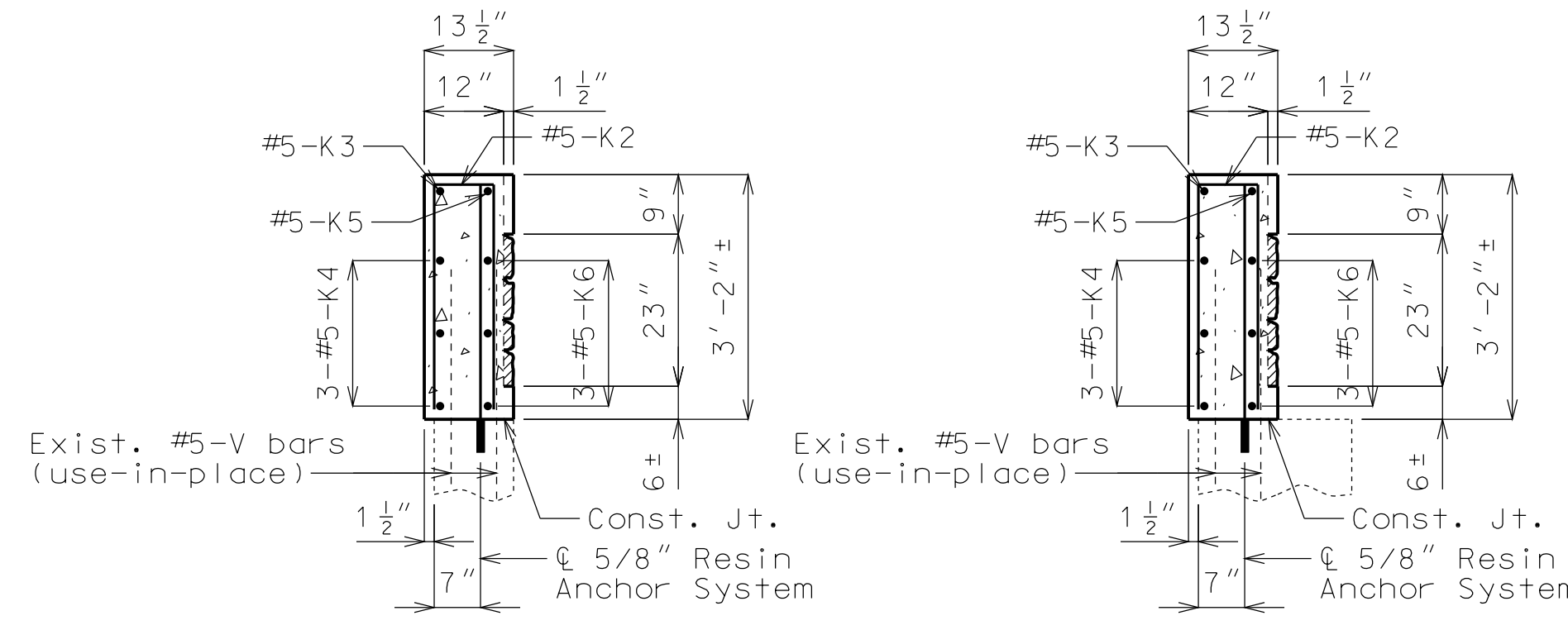

SECTION A-A

SECTION B-B

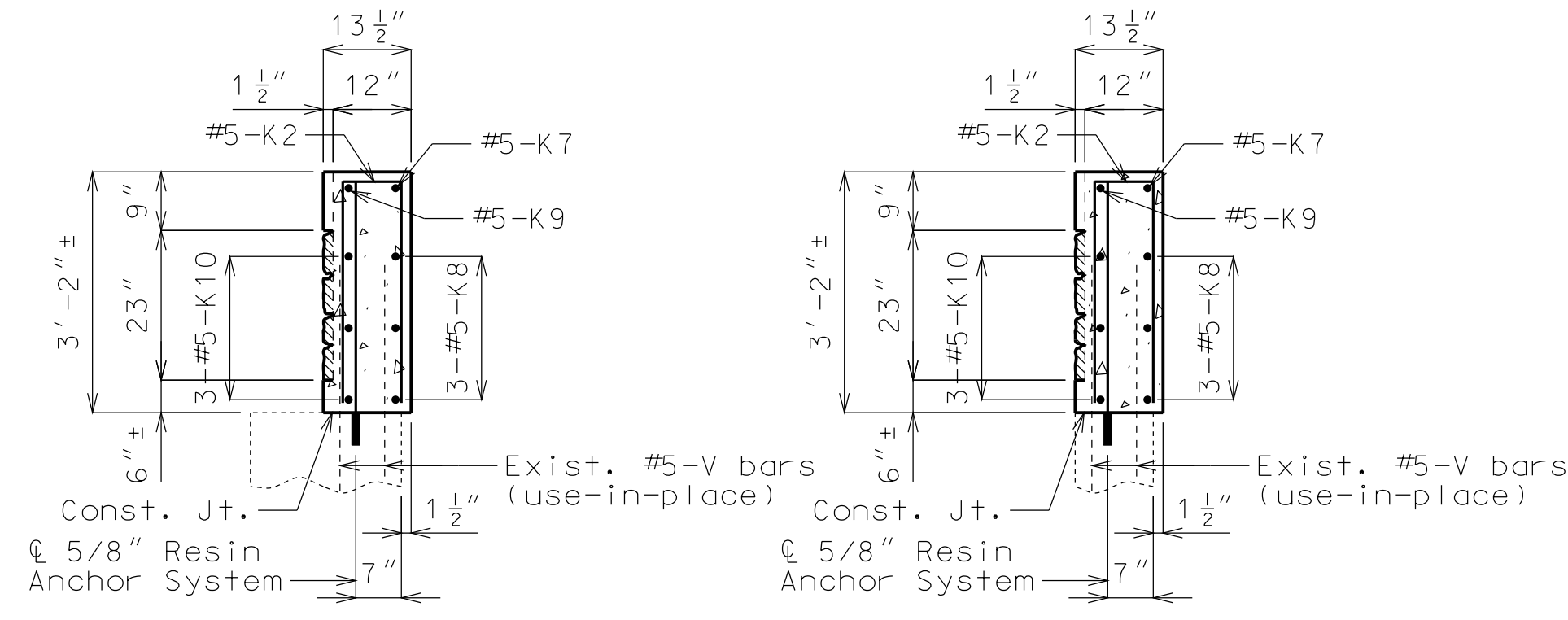

SECTION D-D

SECTION C-C

Notes:
 For details of Corral curb not shown, see Sheet No. 11.
 For details of Aesthetic Treatment, see Sheet No. 11.
 For Ornamental Fence Post spacing, see Sheet No. 9.
 For details of Ornamental Pedestrian Fence, see Sheet No. 10.

DETAILS OF LEFT CORRAL CURB AT END BENTS

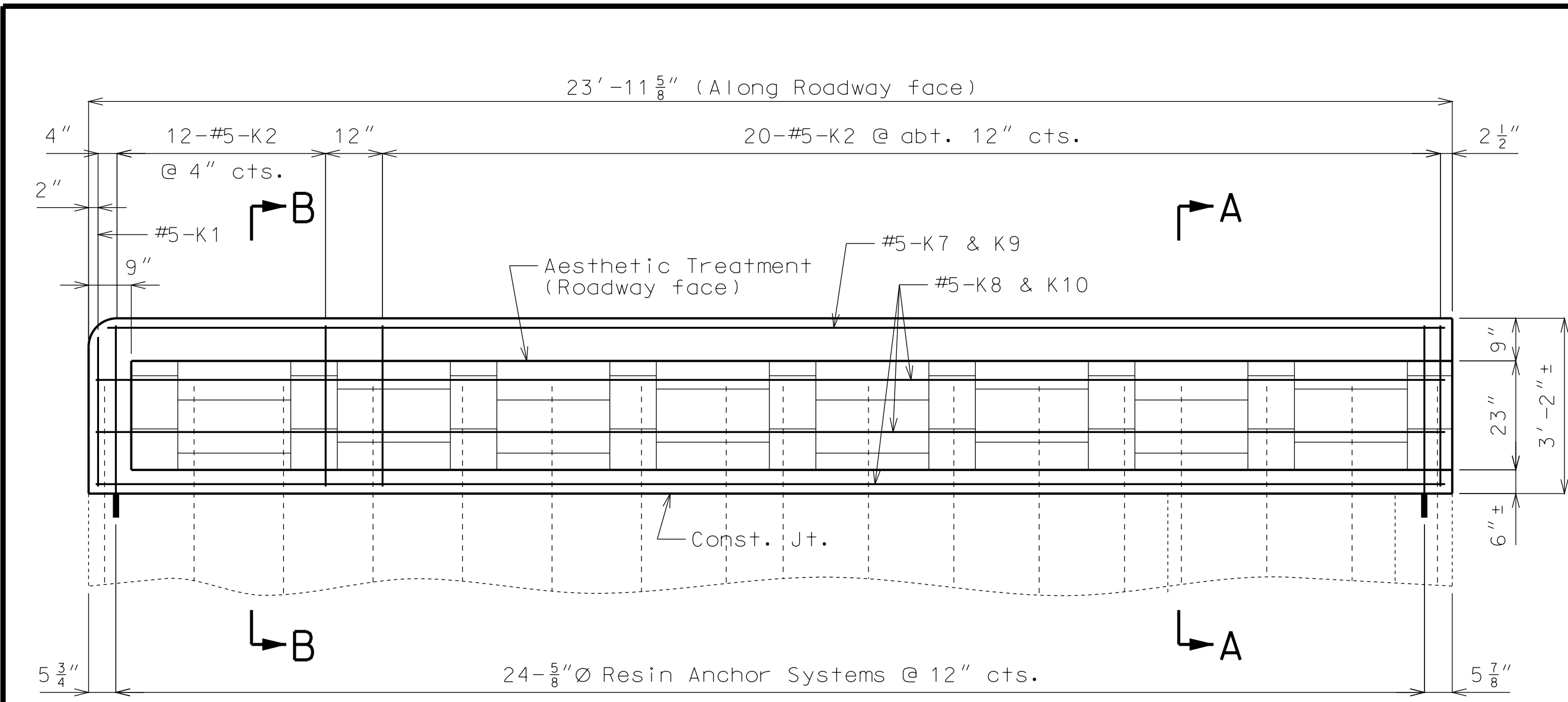

DEVELOPED ELEVATION

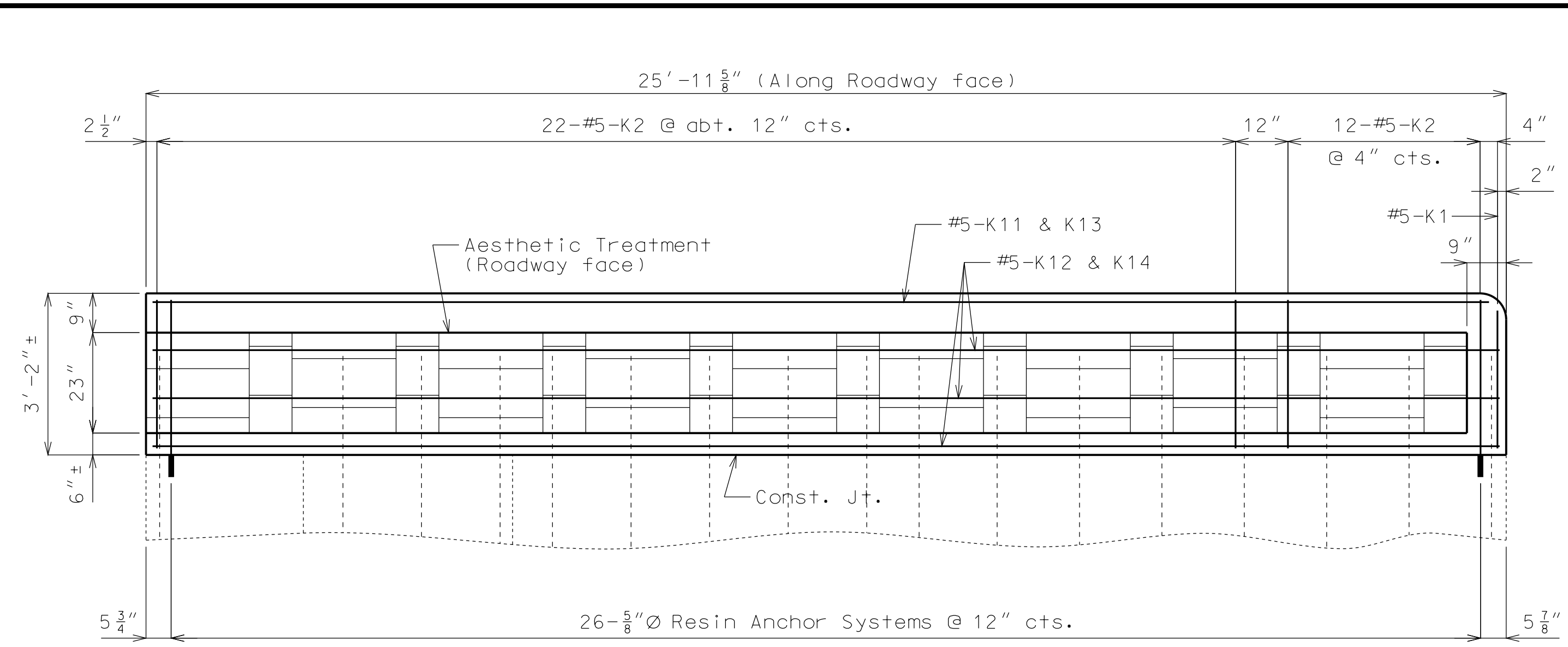

DEVELOPED ELEVATION

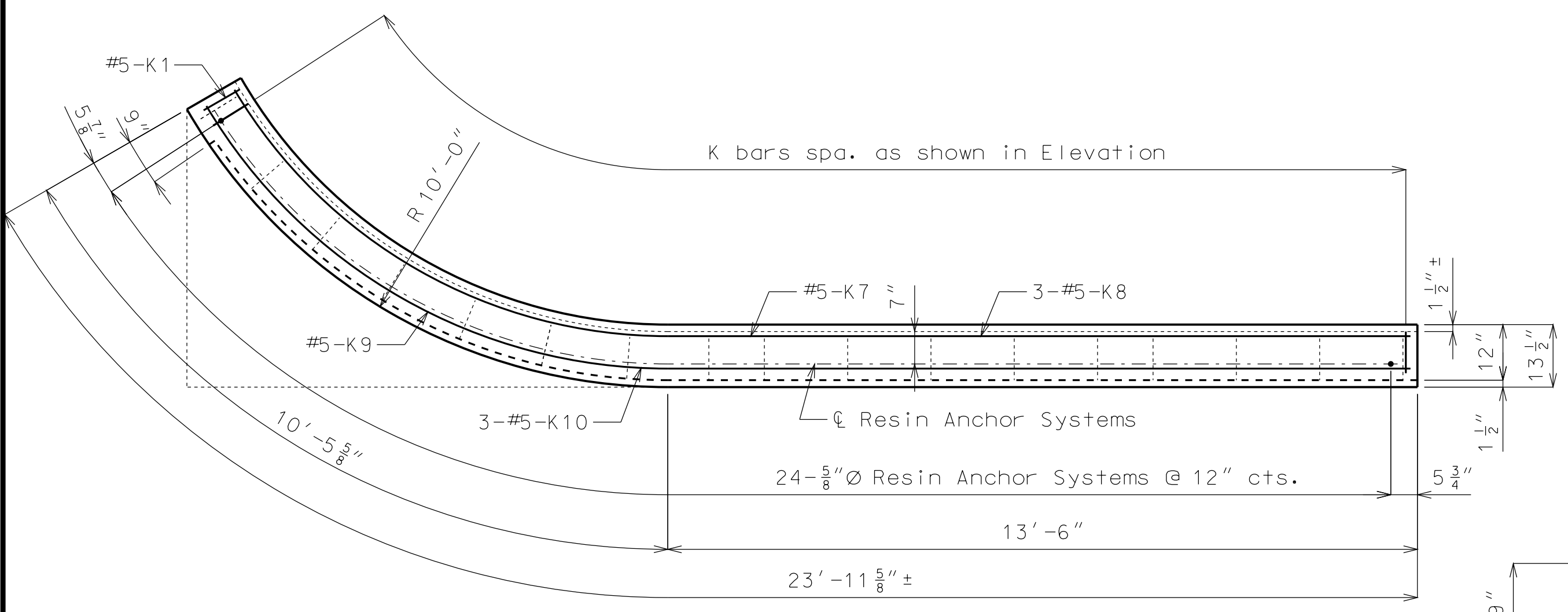

PLAN
END BENT NO. 9

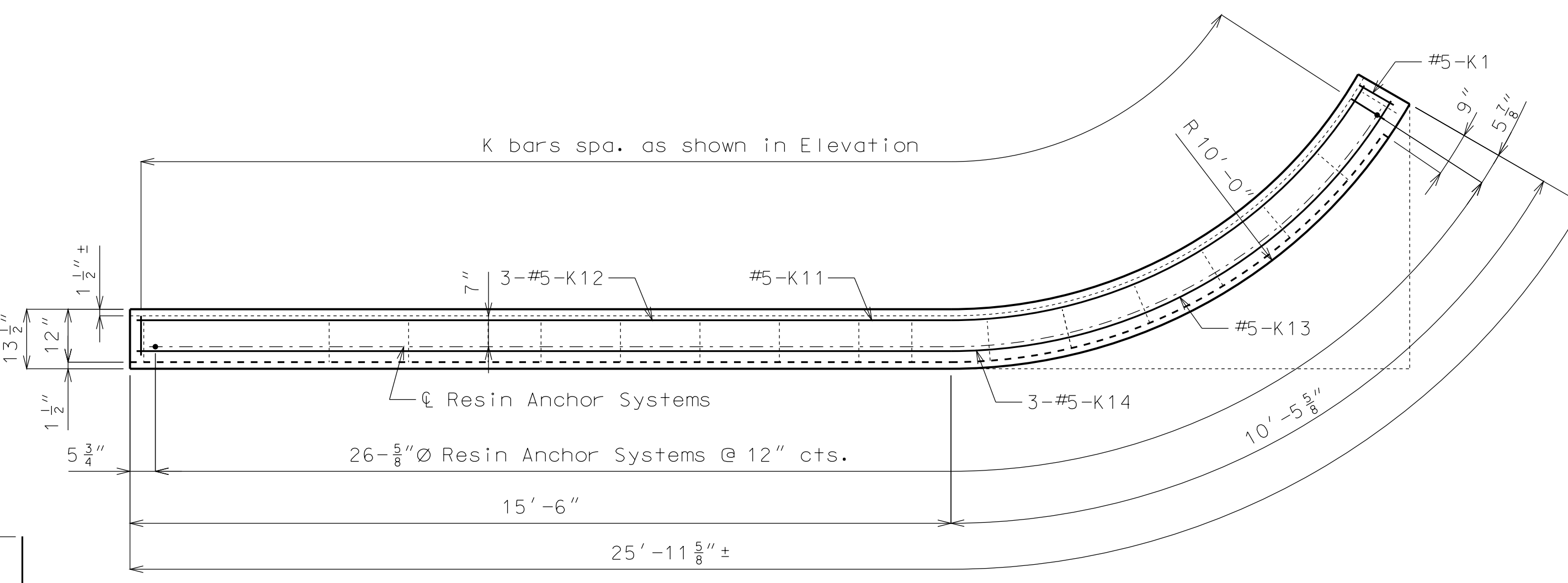

PLAN
END BENT NO. 1

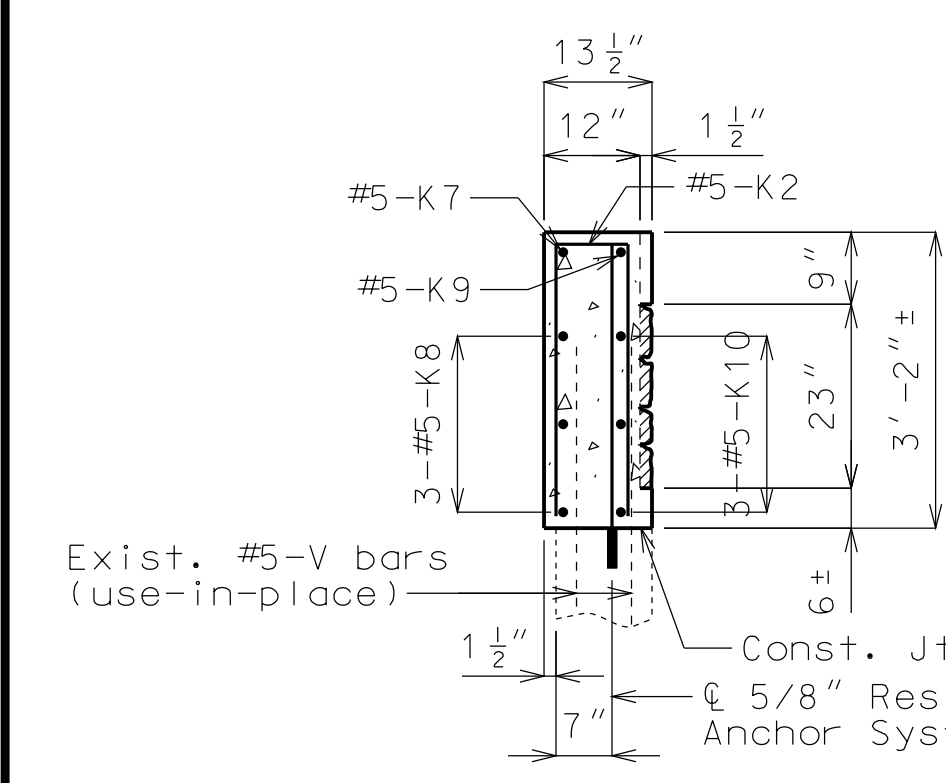

SECTION A-A

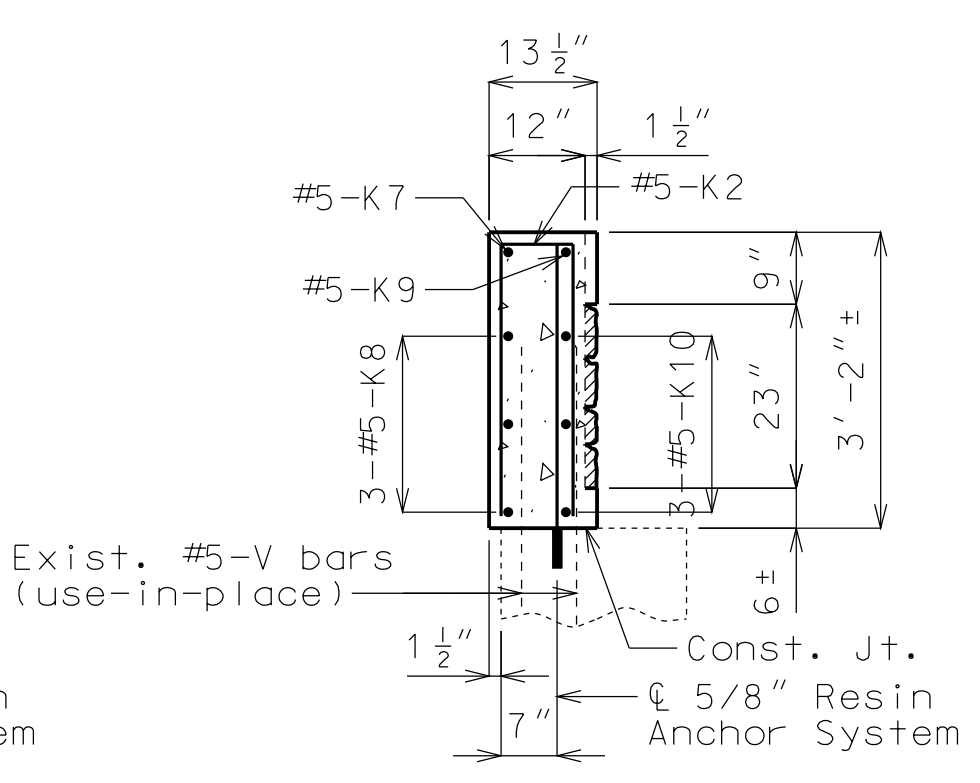

SECTION B-B

* Manufacturer's recommendation
 Total Req'd = 50 for Left Corral Curb and End Bents
 Total Length = 2'-9" + embedment

DETAIL OF RESIN ANCHOR SYSTEM

Resin Anchor Notes:
 The contractor shall use one of the qualified resin anchor systems in accordance with Sec 1039.
 Cost of furnishing and installing the resin anchor system, complete in place, will be considered completely covered by the contract unit price for Reinforced Concrete Slab Overlay.
 The minimum embedment depth in concrete with f'c = 4,000 psi for the resin anchor system shall be that required to meet the minimum ultimate pullout strength in accordance with Sec 1039 but shall not be less than 5".
 An epoxy coated #5 Grade 60 reinforcing bar shall be substituted for the 5/8"Ø threaded rod.

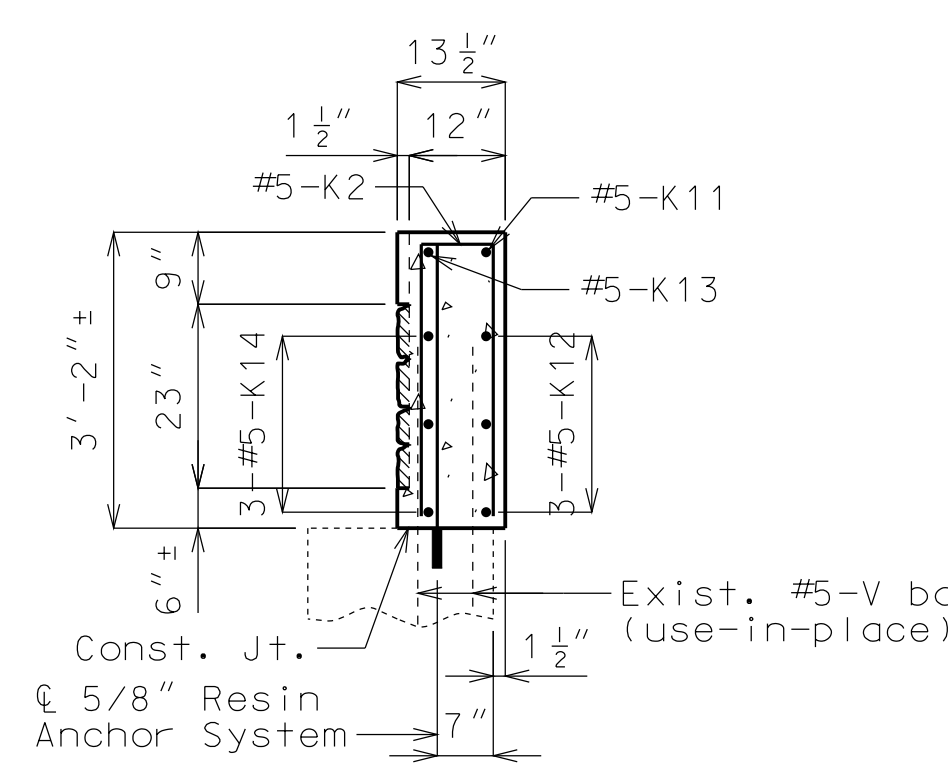

SECTION B-B

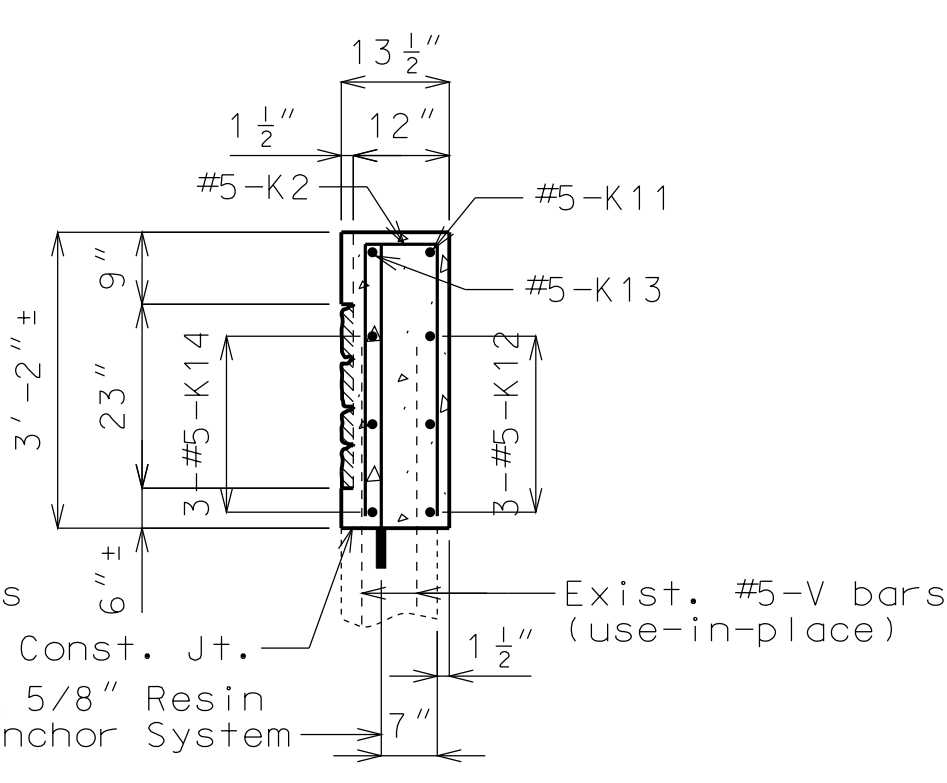

SECTION A-A

Notes:
 For details of Corral curb not shown, see Sheet No. 12.
 For details of Aesthetic Treatment, see Sheet No. 12.
 For Ornamental Fence Post spacing, see Sheet No. 9.
 For details of Ornamental Pedestrian Fence, see Sheet No. 10.

DETAILS OF RIGHT CORRAL CURB AT END BENTS

Detailed Dec. 2013
 Checked Jan. 2014

Note: This drawing is not to scale. Follow dimensions.

Sheet No. 14 of 19

IF A SEAL IS PRESENT ON THIS SHEET IT HAS BEEN ELECTRONICALLY SEALED AND DATED.

"THIS MEDIA SHOULD NOT BE CONSIDERED A CERTIFIED DOCUMENT."

DATE PREPARED 1/22/2014	
ROUTE I-670	STATE MO
DISTRICT BR	SHEET NO. 14
COUNTY JACKSON	
JOB NO. J412023	
CONTRACT ID.	
PROJECT NO.	
BRIDGE NO. A08073	

DESCRIPTION	DATE

MISSOURI HIGHWAYS AND TRANSPORTATION COMMISSION

105 WEST CAPITOL
JEFFERSON CITY, MO 65102
1-888-ASK-MODOT (1-888-275-6636)

"THIS MEDIA SHOULD NOT BE CONSIDERED A CERTIFIED DOCUMENT."

DATE PREPARED
1/22/2014

ROUTE STATE
I-670 MO

DISTRICT SHEET NO.
BR 15

COUNTY

JACKSON

JOB NO.

J412023

CONTRACT ID.

PROJECT NO.

BRIDGE NO.

A08073

DESCRIPTION

DATE

MISSOURI HIGHWAYS AND TRANSPORTATION COMMISSION

105 WEST CAPITOL
JEFFERSON CITY, MO 65102
1-888-ASK-MODOT (1-888-275-6636)

IF A SEAL IS PRESENT ON THIS SHEET IT HAS BEEN ELECTRONICALLY SEALED AND DATED.

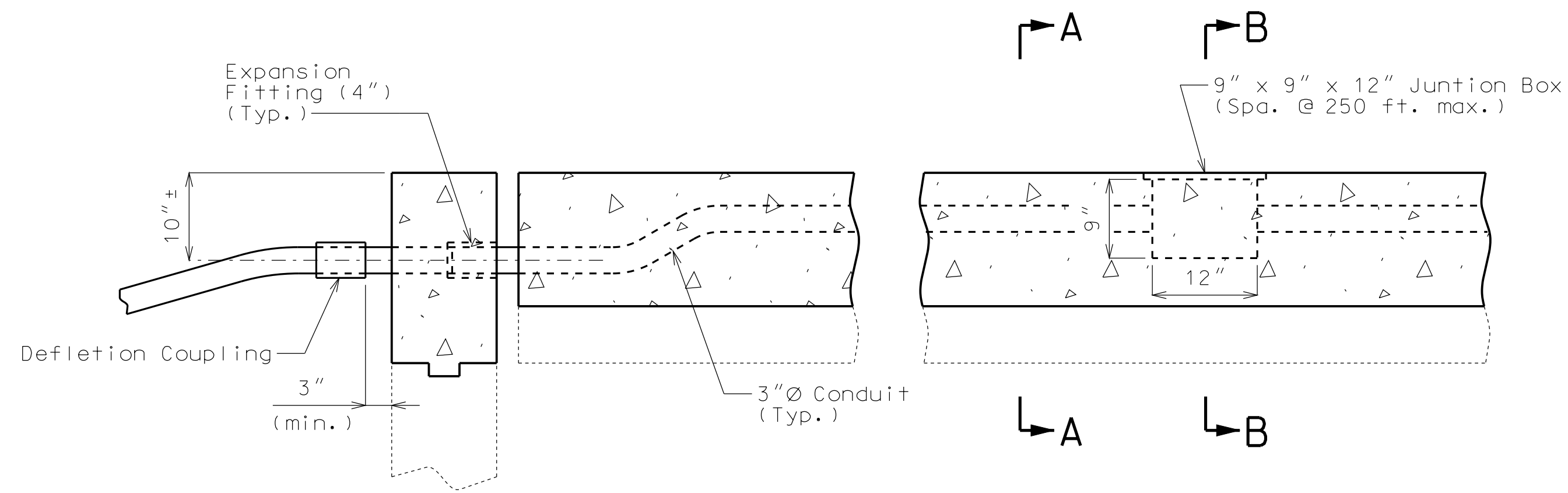

PART SECTION THRU SIDEWALK NEAR CONDUIT

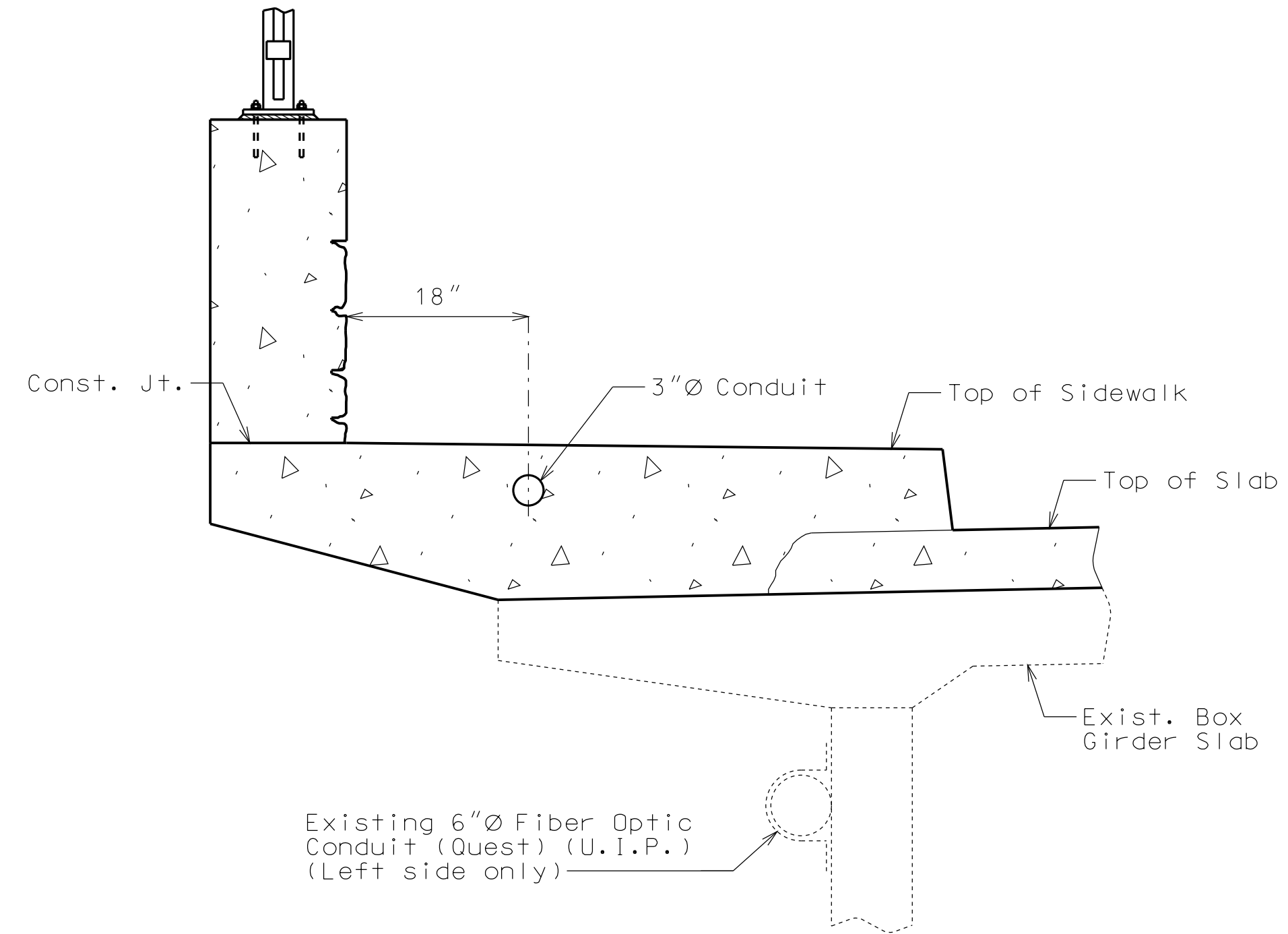

SECTION A-A

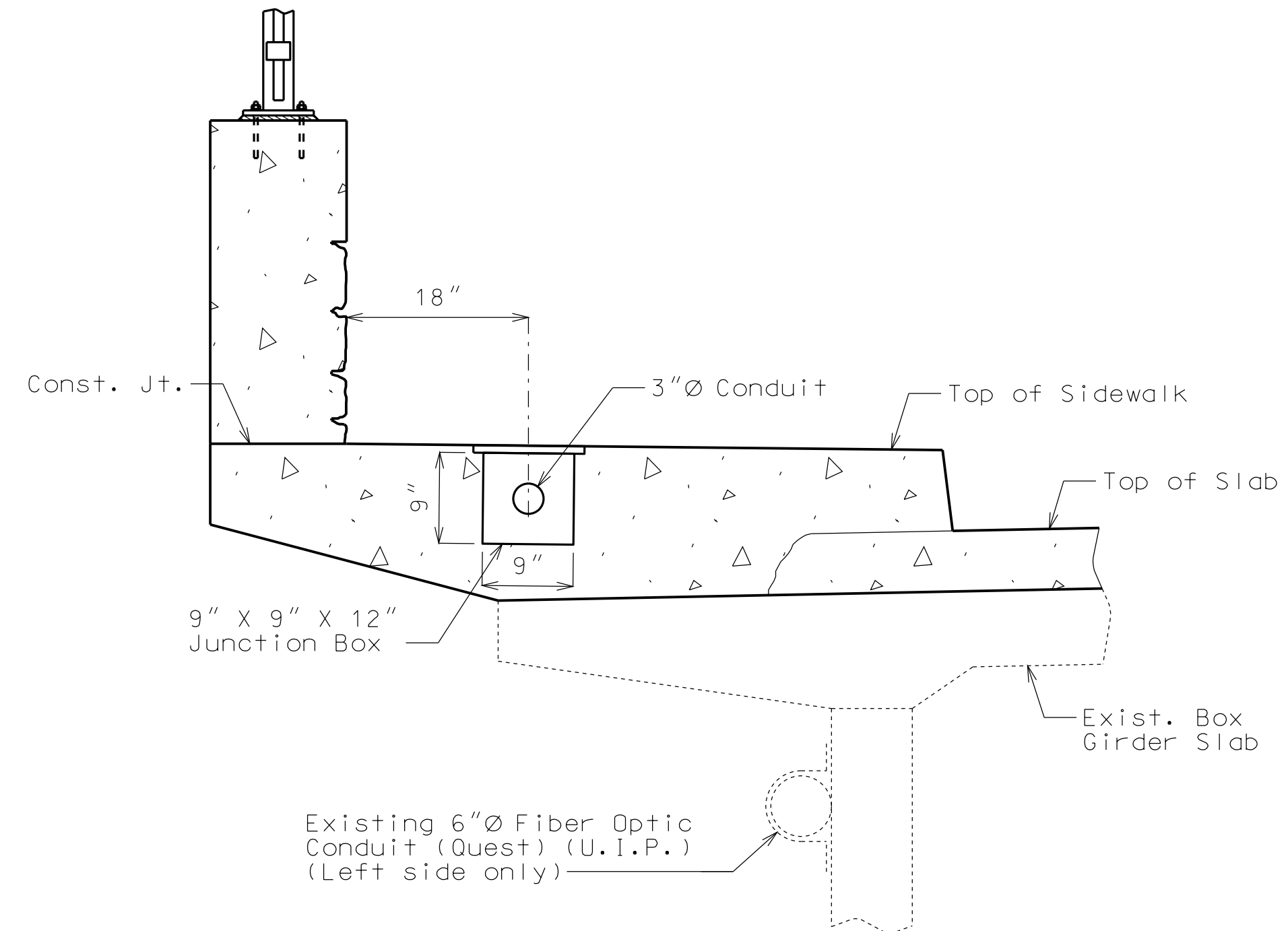

SECTION B-B

Notes:

All conduits shall be rigid nonmetallic schedule 40 heavy wall polyvinyl chloride (PVC) with 3" minimum cover in concrete. Each section of conduit shall bear the Underwriters Laboratories (UL) label.

Shift reinforcing steel in field where necessary to clear conduit and junction boxes.

Expansion fittings shall be placed as shown and set in accordance with the manufacturer's requirements and based on the air temperature at the time of setting given an estimated total expansion movement of 4" at open joints and 1" at filled joints using a maximum temperature range of 120 F° and a maximum temperature of 110 F°.

All sidewalk junction boxes shall be PVC molded in accordance with Sec 1062 and designed for flush mounting. The conduit terminations shall be permanent or separable. The terminations and covers shall be of watertight construction and shall meet requirements for NEMA 4 enclosure.

Drainage shall be provided at low points or other critical locations of all conduits and all junction boxes in accordance with Sec 707. All conduits shall be sloped to drain where possible.

Payment for furnishing and installing Conduit System, complete in place, will be considered completely covered by the contract lump sum price for Conduit System on Structure.

DETAILS OF CONDUIT SYSTEM ON STRUCTURE

(Left side shown, right side similar)

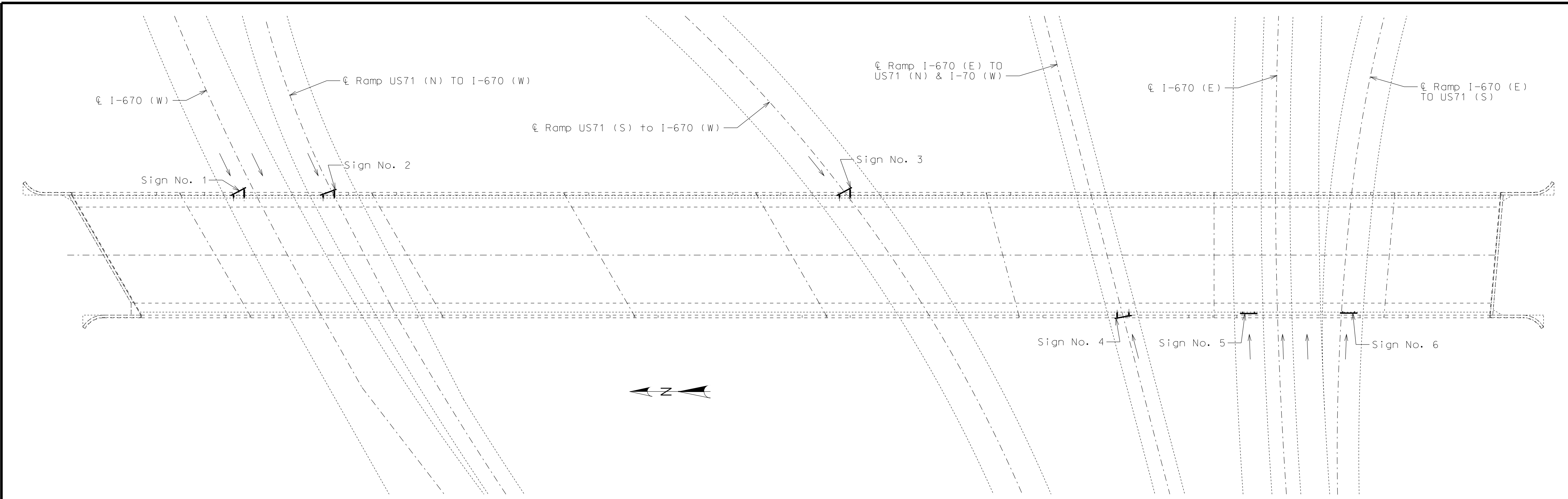

PLAN SHOWING SIGN LOCATIONS

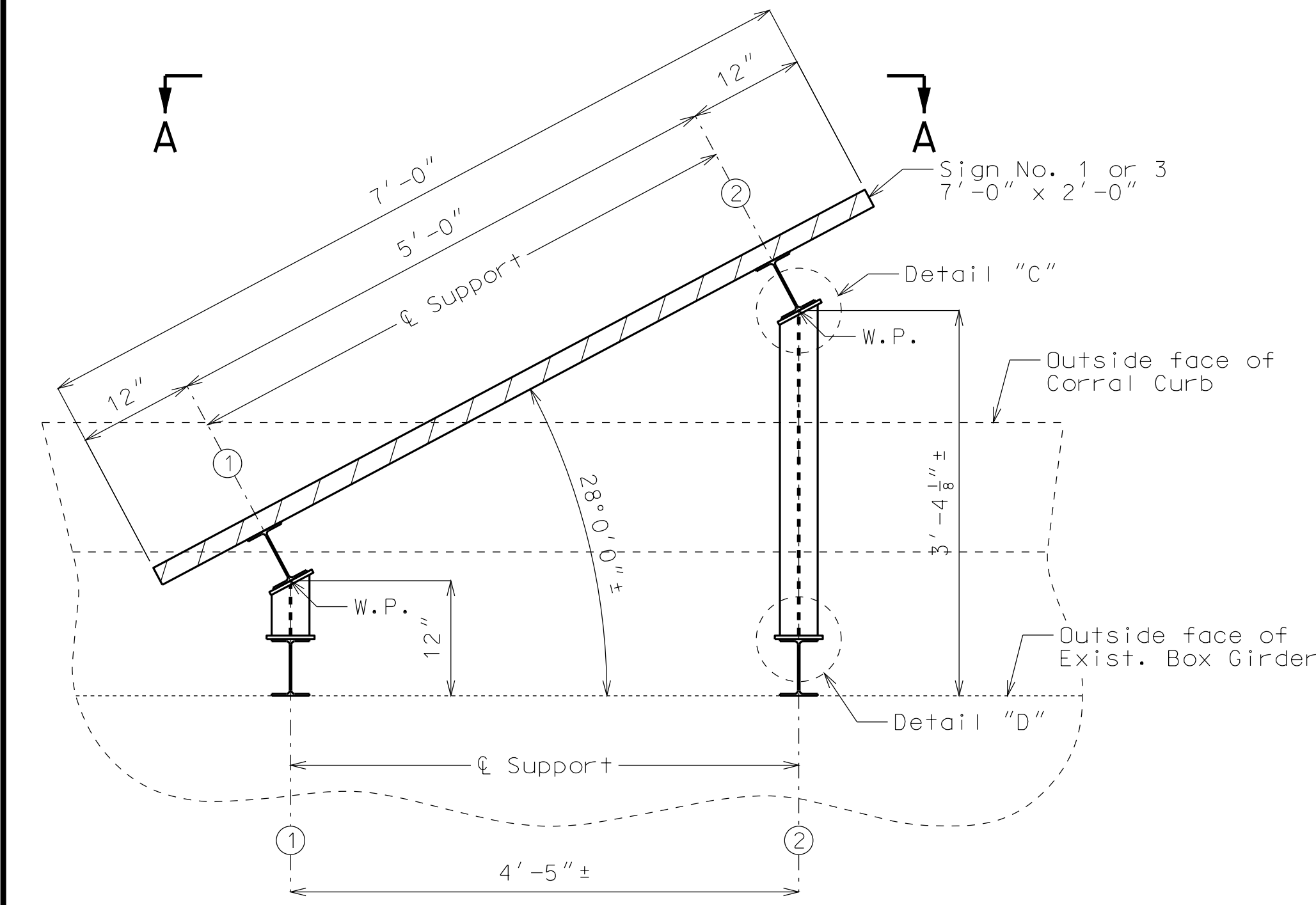

PART PLAN SHOWING DIMENSIONS OF SIGNS NO. 1 & 3

(Sign No. 1 to be centered over North lane of I-670 (W))
 (Sign No. 3 to be centered over Ramp US71 (S) to I-670 (W))

Notes:
 Work this sheet with Sheets No. 17 & 18.
 For Elevations A-A & B-B, see Sheet No. 17.
 For Details "C" & "D", see Sheet No. 17.

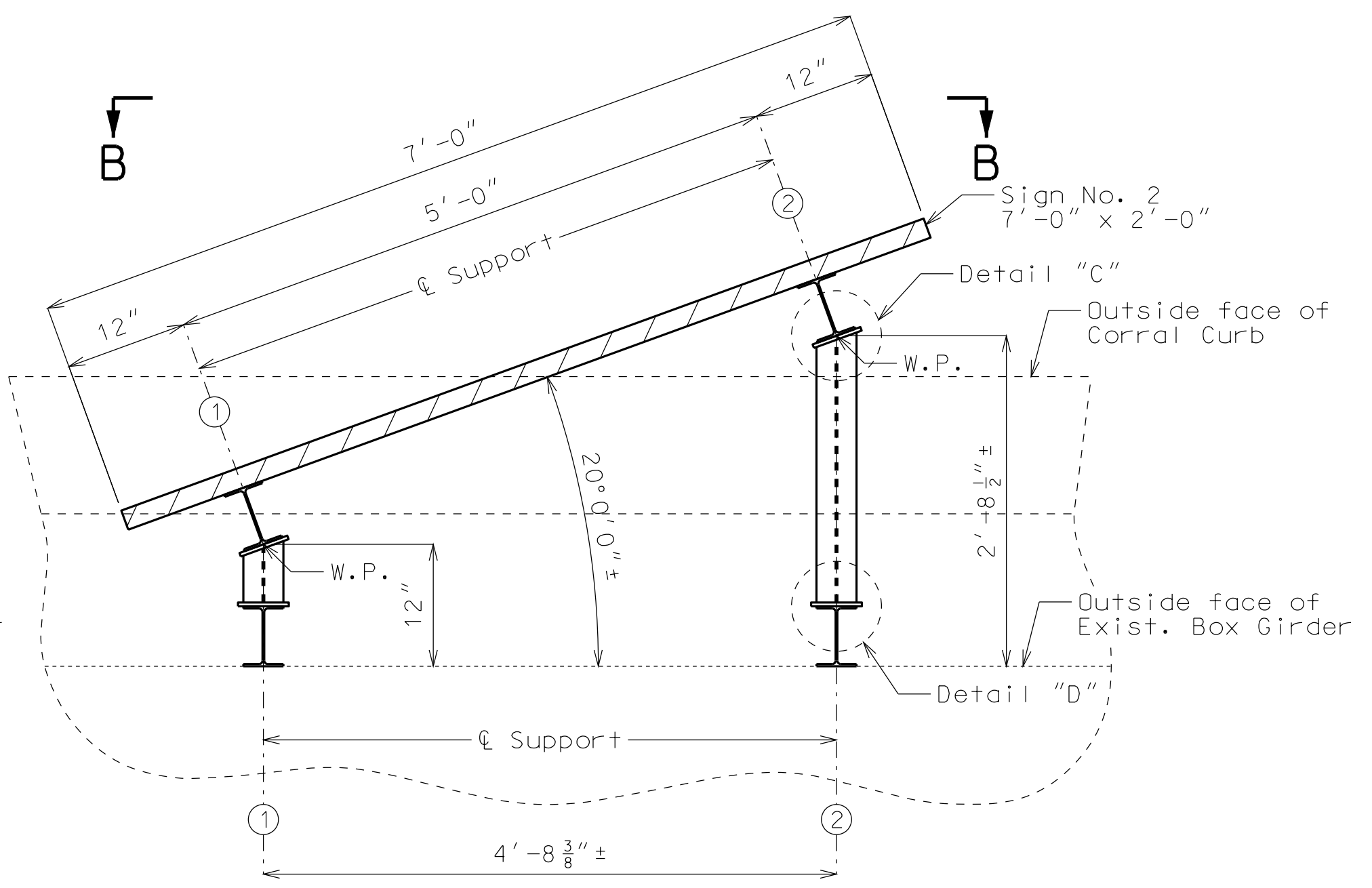

PART PLAN SHOWING DIMENSIONS OF SIGN NO. 2

(Sign No. 2 to be centered over Ramp US71 (N) to I-670 (W))

Notes:
 Center and level signs on supports.
 All bolts, nuts and washers shall be galvanized.
 All structural steel shall be ASTM A709, Grade 36, galvanized.
 The cost of furnishing and erecting the sign supports, including the concrete anchors complete in place, will be considered completely covered by the contract lump sum price for "Fabricated Sign Support Brackets."
 Concrete anchors shall be the non-drilling expansion type and shall have a certified concrete pullout strength (Ultimate Load) of 12,100 pounds (min.) in 4,000 psi concrete. The hole shall be pre-drilled with a conventional carbide masonry bit.
 Bolt threads shall be burred after sign has been erected.
 See Roadway Plans for removal of existing sign.
 If any concrete is damaged when removing sign it shall be restored with qualified special mortar in accordance with Sec 704 and will be considered completely covered by the contract unit price for other items included in the contract.
 The existing sign anchor bolts shall be cut off 1/2" below the exposed face of the concrete. The cutting and removal of existing sign anchor bolts will be considered completely covered by the contract unit price for other items included in the contract.
 All holes in concrete existing after sign has been removed shall be filled with qualified special mortar in accordance with Sec 704 and will be considered completely covered by the contract unit price for other items included in the contract.
 Shift sign support brackets to minimum extent necessary to allow for installation of anchors into existing structure and to clear existing concrete joints and any utilities.
 Contractor shall verify all skew angles of signs before fabricating W6 x 9 brackets.
 The signs shall be placed to avoid any part of the sign extending below bottom surface of existing concrete box girder.

SIGN SUPPORT BRACKETS

"THIS MEDIA SHOULD NOT BE CONSIDERED A CERTIFIED DOCUMENT."

DATE PREPARED 1/22/2014	
ROUTE I-670	STATE MO
DISTRICT BR	SHEET NO. 16
COUNTY JACKSON	
JOB NO. J412023	
CONTRACT ID.	
PROJECT NO.	
BRIDGE NO. A08073	

DATE	DESCRIPTION

MISSOURI HIGHWAYS AND TRANSPORTATION COMMISSION

105 WEST CAPITOL
 JEFFERSON CITY, MO 65102
 1-888-ASK-MODOT (1-888-275-6636)

IF A SEAL IS PRESENT ON THIS SHEET IT HAS BEEN ELECTRONICALLY SEALED AND DATED.

"THIS MEDIA SHOULD NOT BE CONSIDERED A CERTIFIED DOCUMENT."

DATE PREPARED
1/22/2014
ROUTE I-670 STATE MO
DISTRICT BR SHEET NO. 17

COUNTY JACKSON
JOB NO. J412023
CONTRACT ID.

PROJECT NO.
BRIDGE NO. A08073

DESCRIPTION	DATE

MISSOURI HIGHWAYS AND TRANSPORTATION COMMISSION

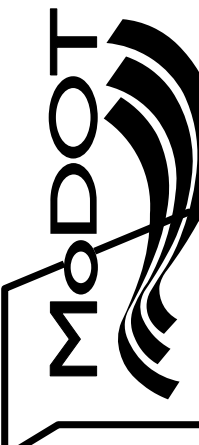

105 WEST CAPITOL
JEFFERSON CITY, MO 65102
1-888-ASK-MODOT (1-888-275-6636)

IF A SEAL IS PRESENT ON THIS SHEET IT HAS BEEN ELECTRONICALLY SEALED AND DATED.

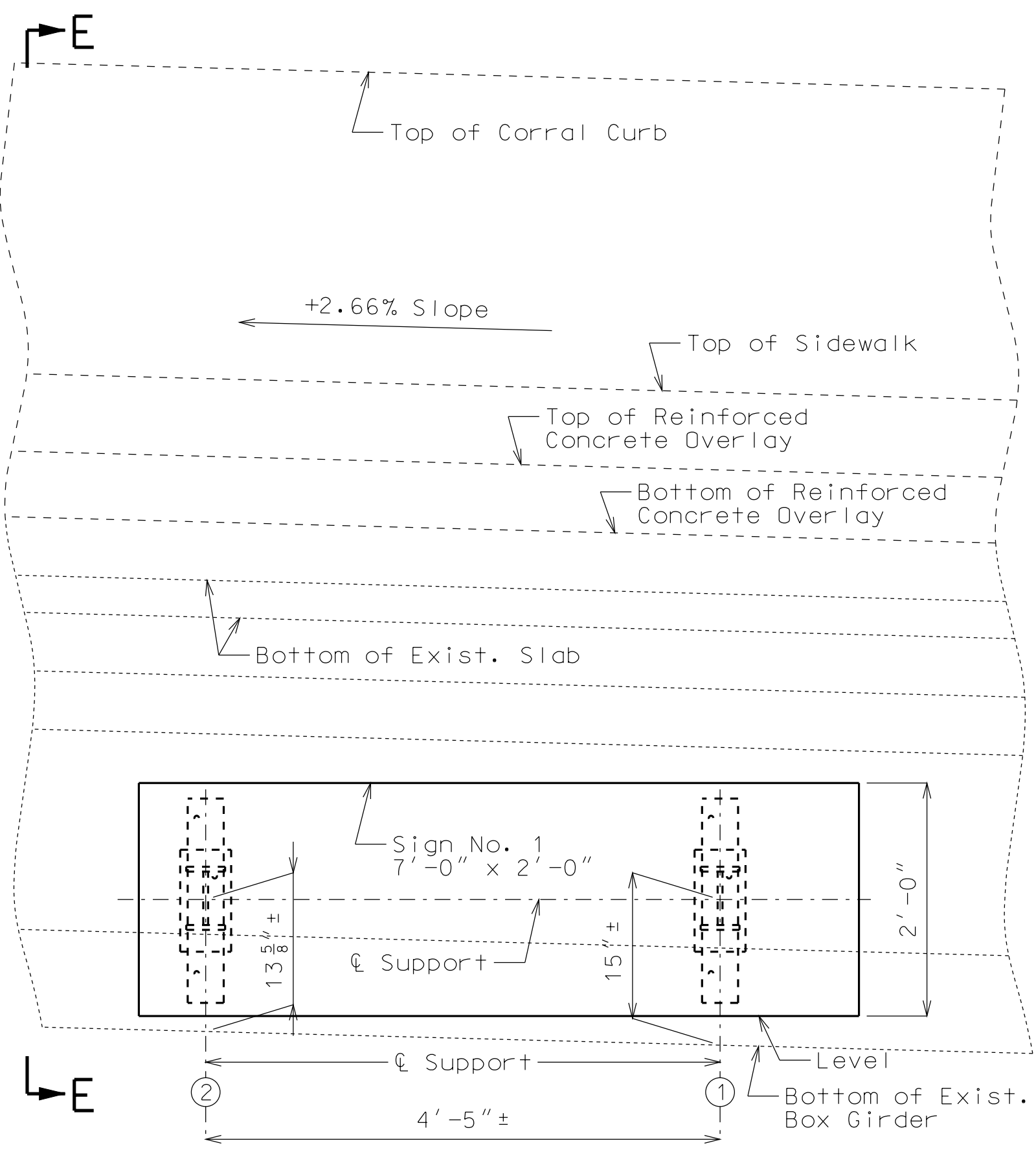

ELEVATION A-A
(Sign No. 1)

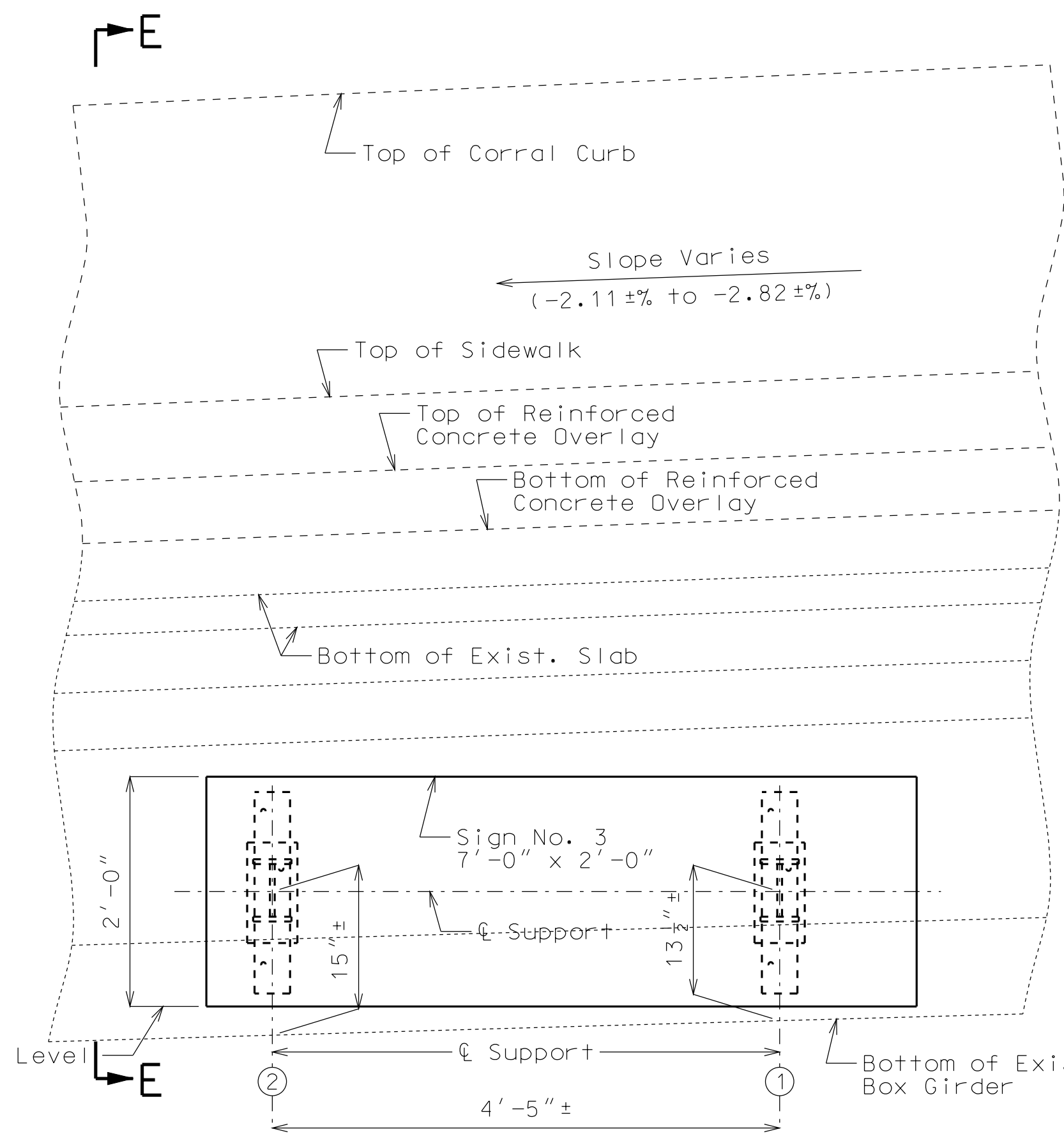

ELEVATION A-A
(Sign No. 3)

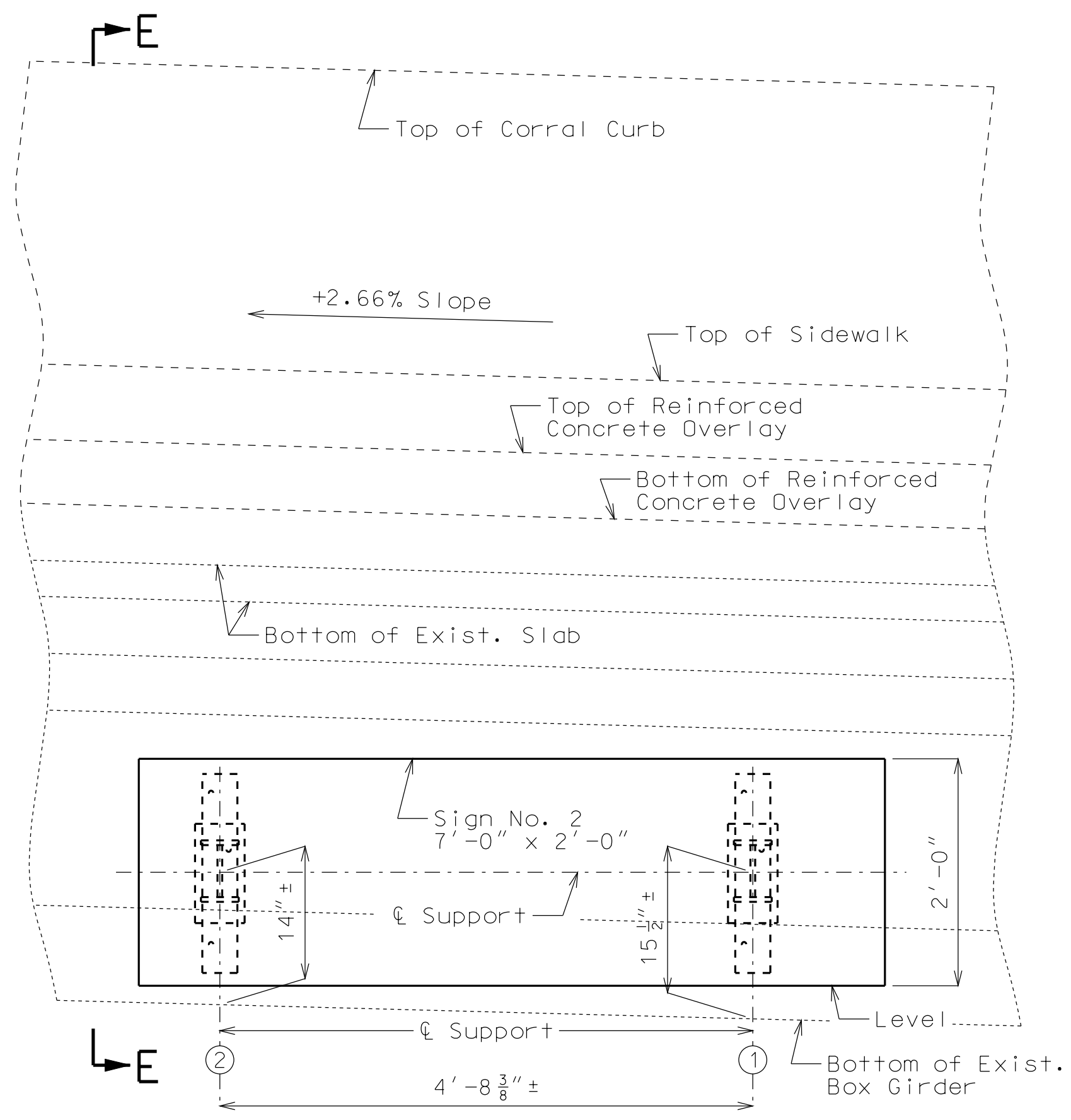

ELEVATION B-B
(Sign No. 2)

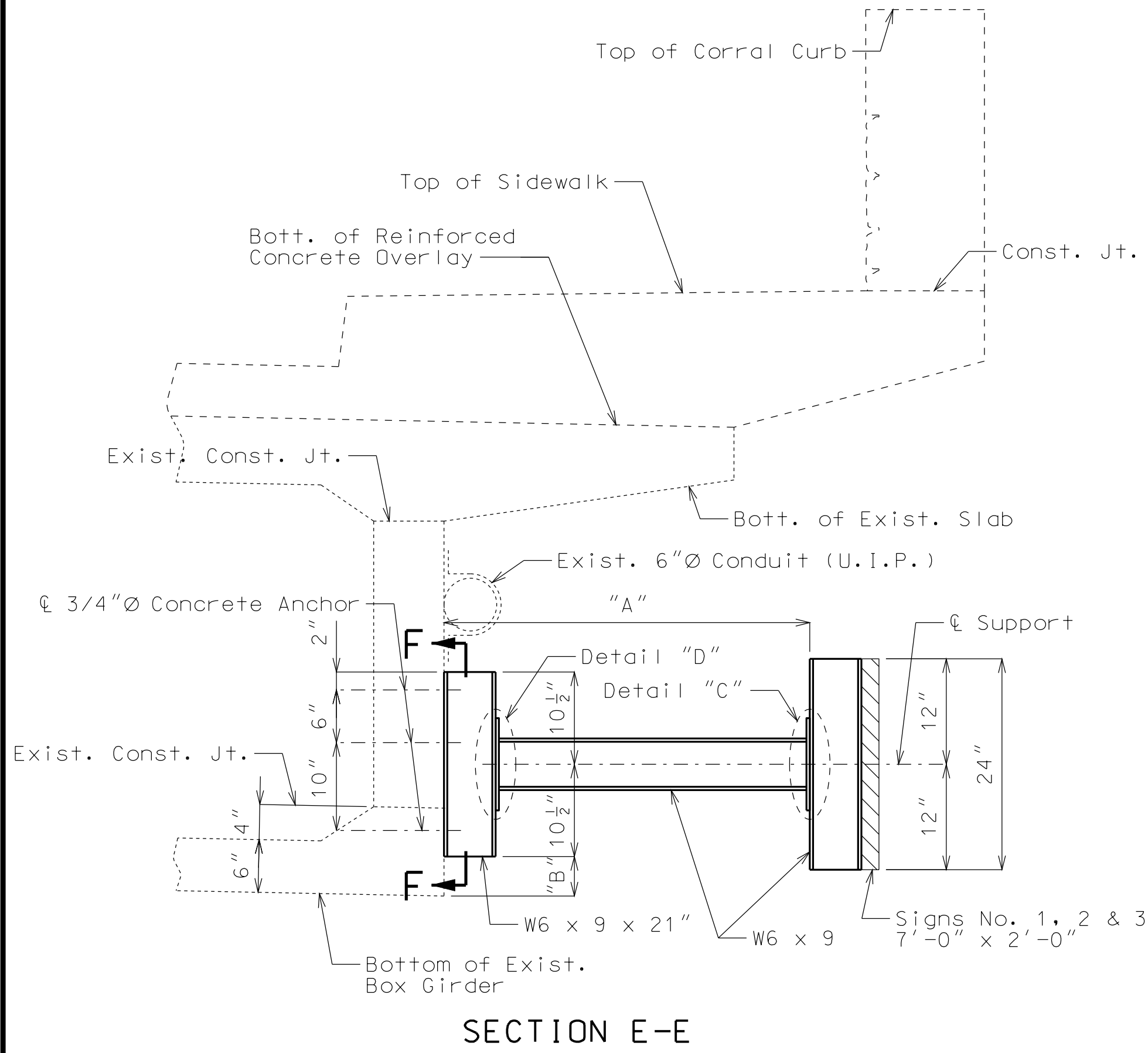

SECTION E-E

Support Bracket No. 1			
Support	"A"	"B"	"C"
1	12"	4 1/2"±	28°0'0"±
2	3'-4 1/8"±	3 1/8"±	28°0'0"±
Support Bracket No. 2			
Support	"A"	"B"	"C"
1	12"	5"±	20°0'0"±
2	2'-8 1/2"±	3 1/2"±	20°0'0"±
Support Bracket No. 3			
Support	"A"	"B"	"C"
1	12"	3"±	28°0'0"±
2	3'-4 1/8"±	4 1/2"±	28°0'0"±

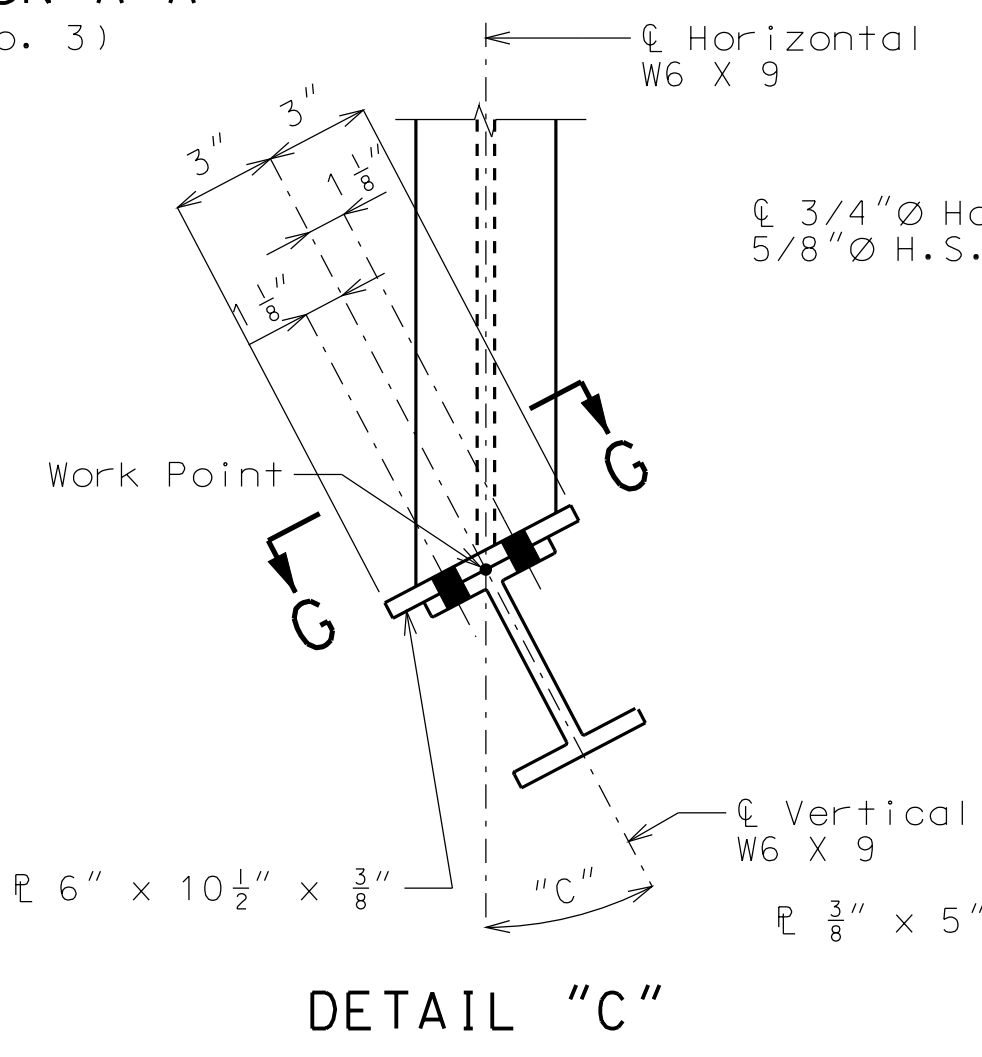

DETAIL "C"

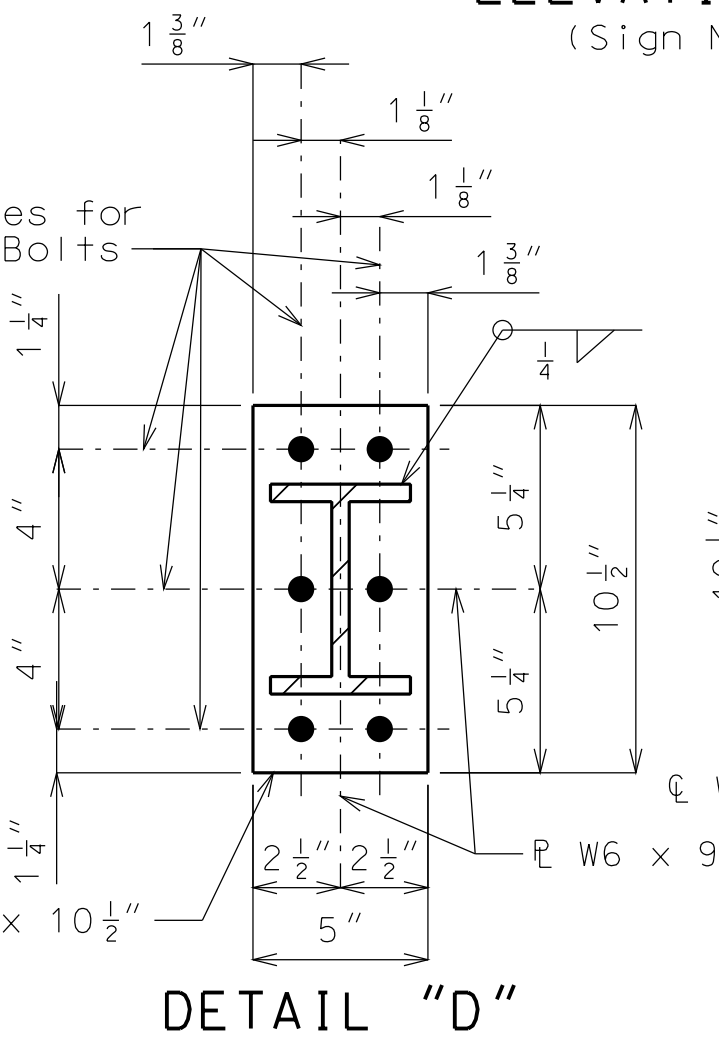

DETAIL "D"

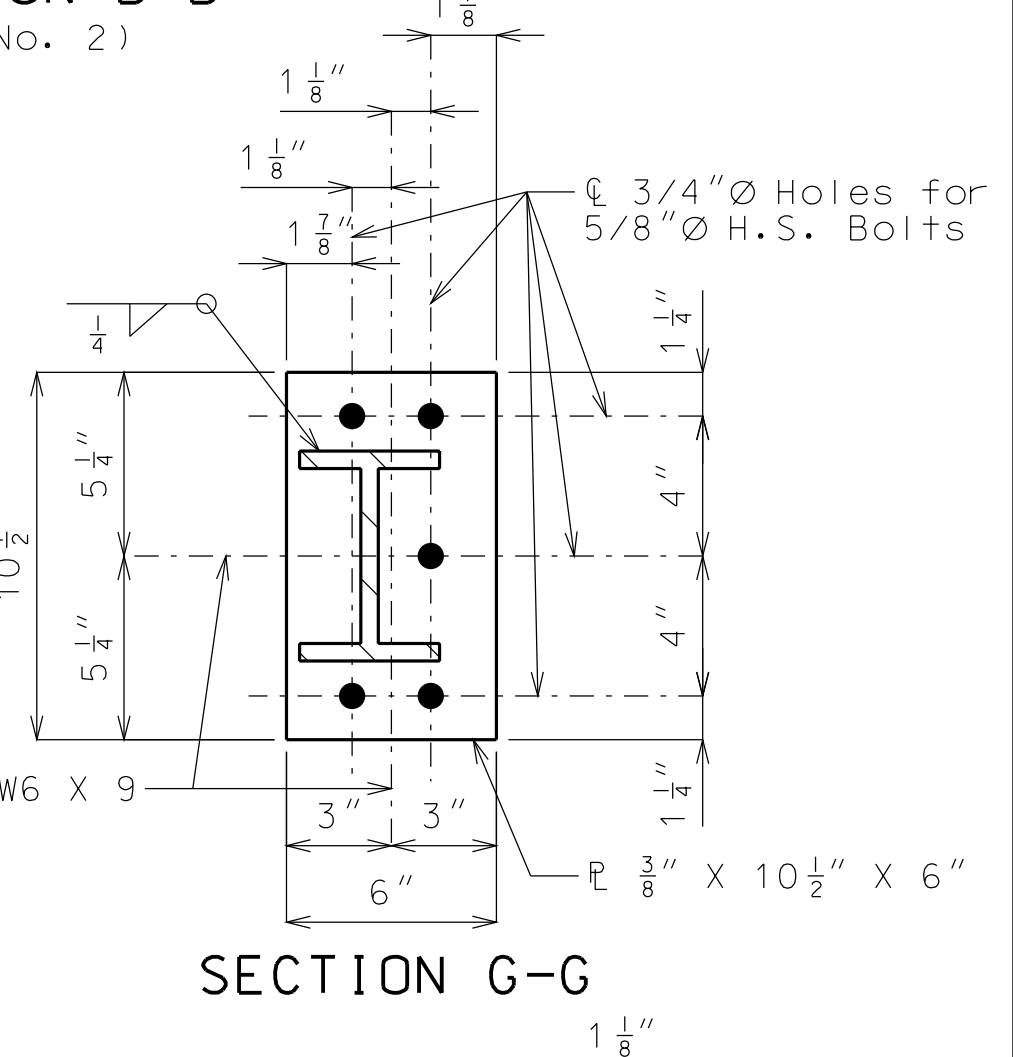

SECTION G-G

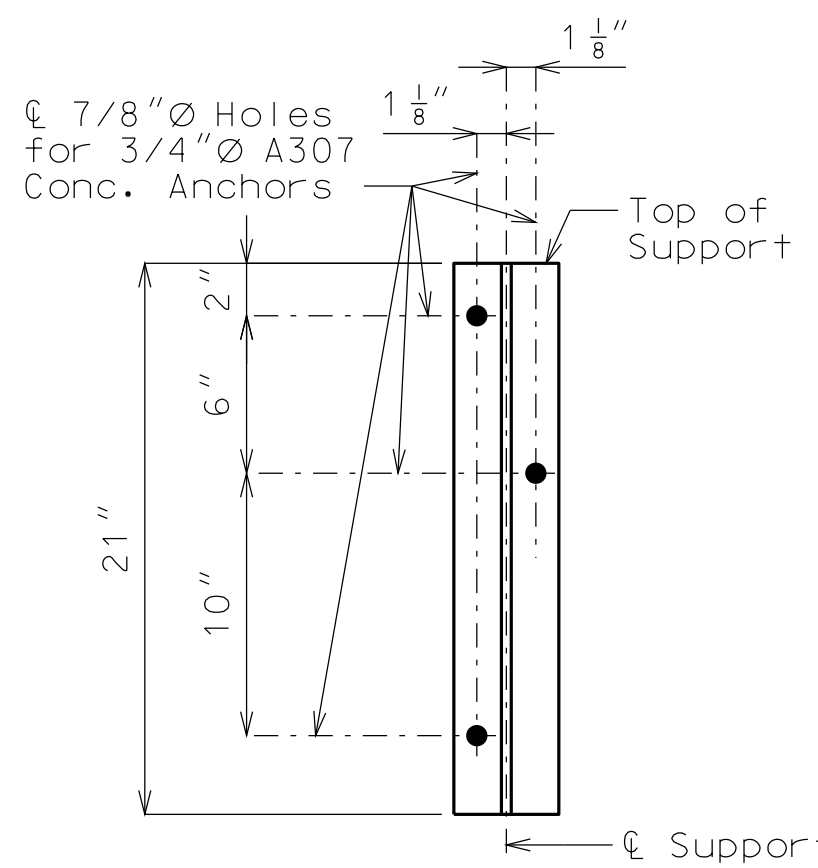

SECTION F-F

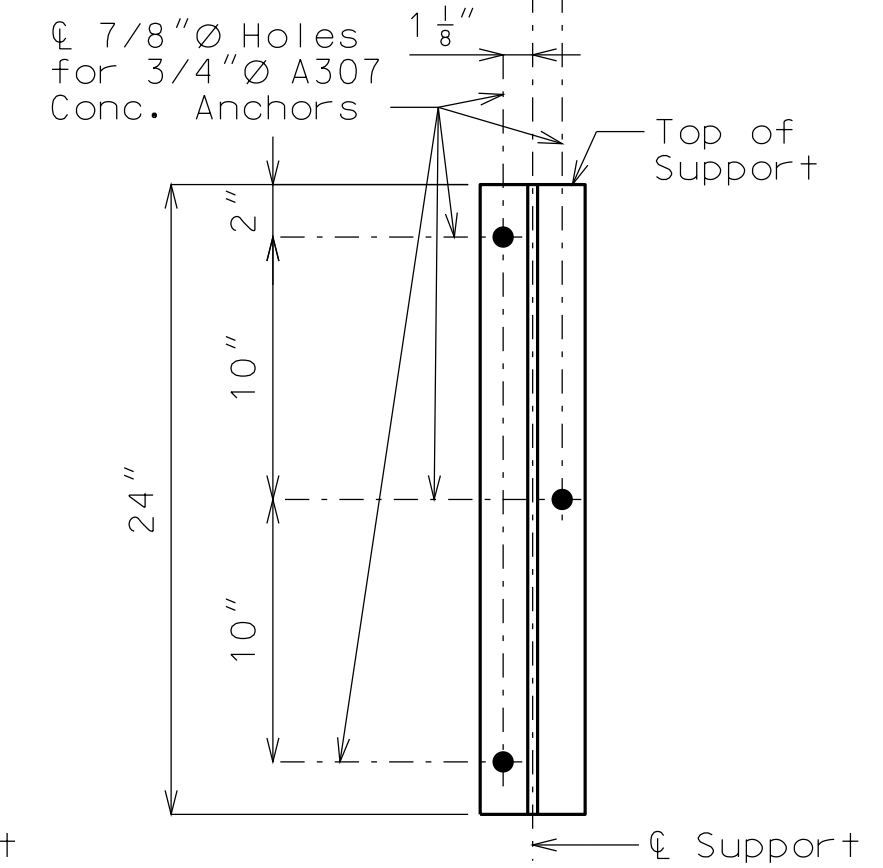

SECTION L-L

Notes:
For General Notes for Sign Support Brackets, see Sheet No. 16.
Work this sheet with Sheets No. 16 & 18.
For locations of Elevations A-A & B-B, see Sheet No. 16.
For locations of Details "C" & "D", see Sheets No. 16 & 18.
For location of Section L-L, see Sheet No. 18.

SIGN SUPPORT BRACKETS

Detailed Jan. 2014
Checked Jan. 2014

Note: This drawing is not to scale. Follow dimensions.

Sheet No. 17 of 19

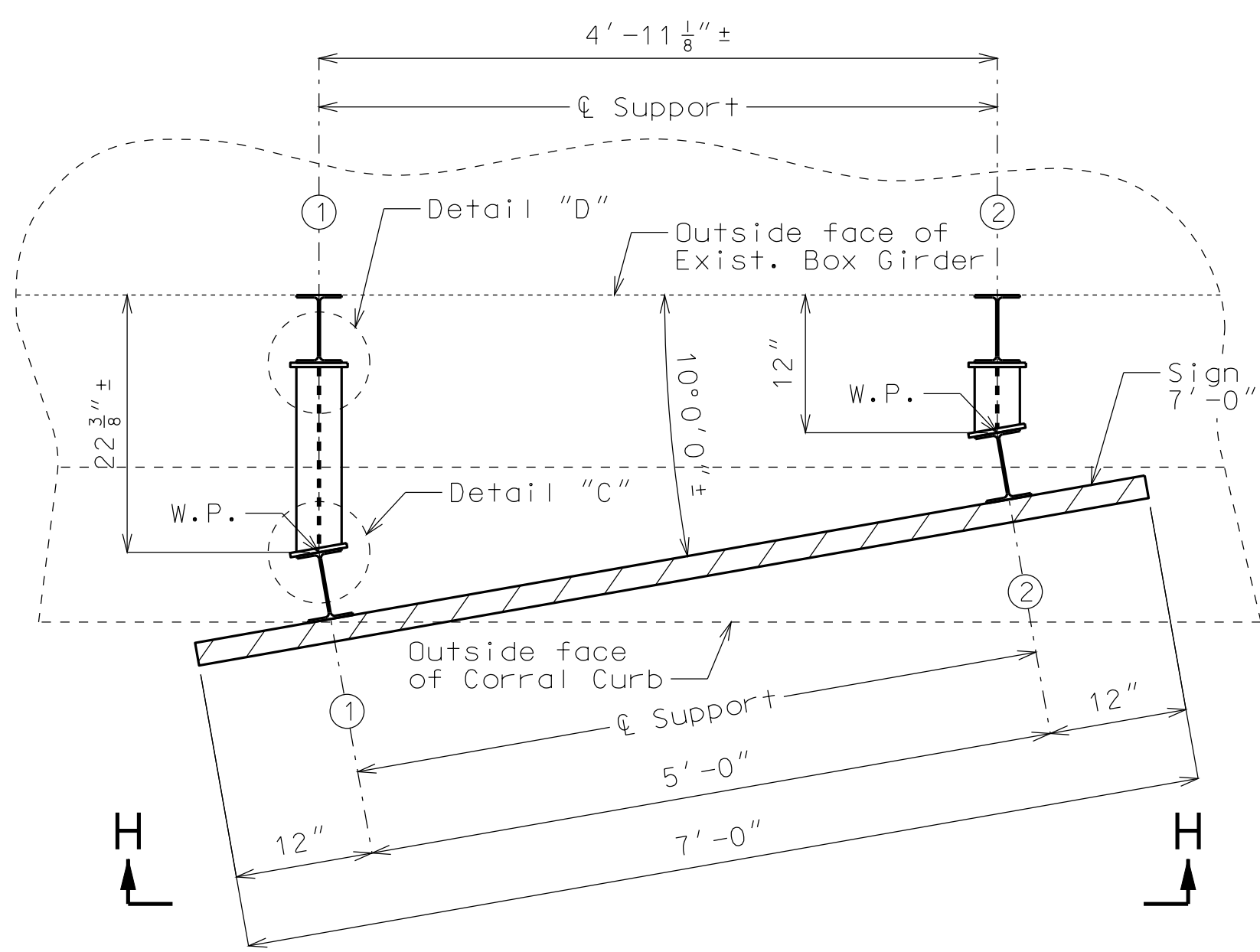

PART PLAN SHOWING DIMENSIONS OF SIGN NO. 4

(Sign No. 4 to be centered over I-670 (E) to US71 (N) & I-70 (W))

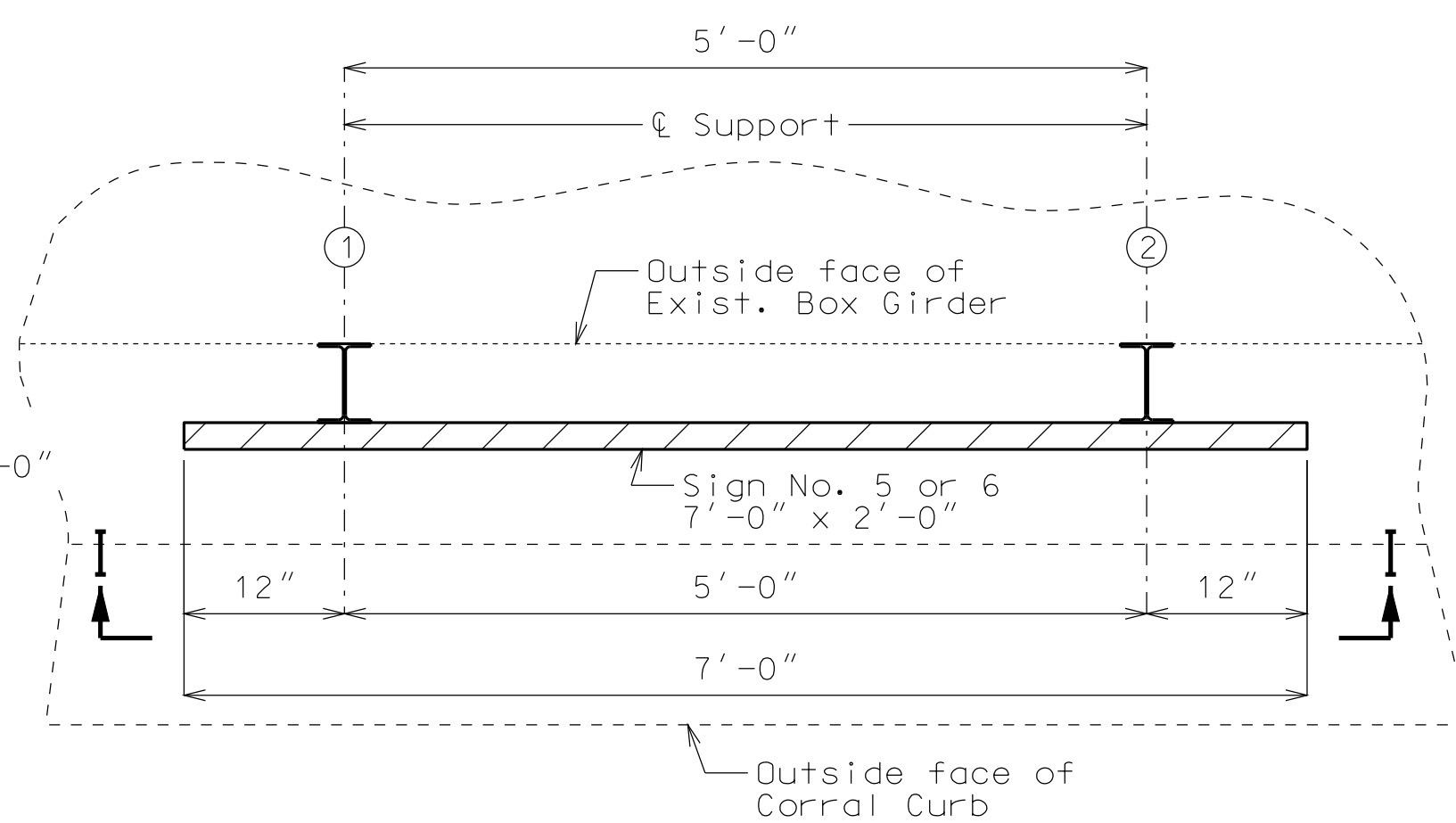

PART PLAN SHOWING DIMENSIONS OF SIGN NO. 5 & 6

(Sign No. 5 to be centered over North lane of I-670 (E))

(Sign No. 6 to be centered over Ramp I-670 (E) to US71 (S))

Notes:
For General Notes for Sign Support Brackets, see Sheet No. 16.
Work this sheet with Sheets No. 16 & 17.
For Details "C" & "D", see Sheets No. 17.
For Section L-L, see Sheet No. 17.

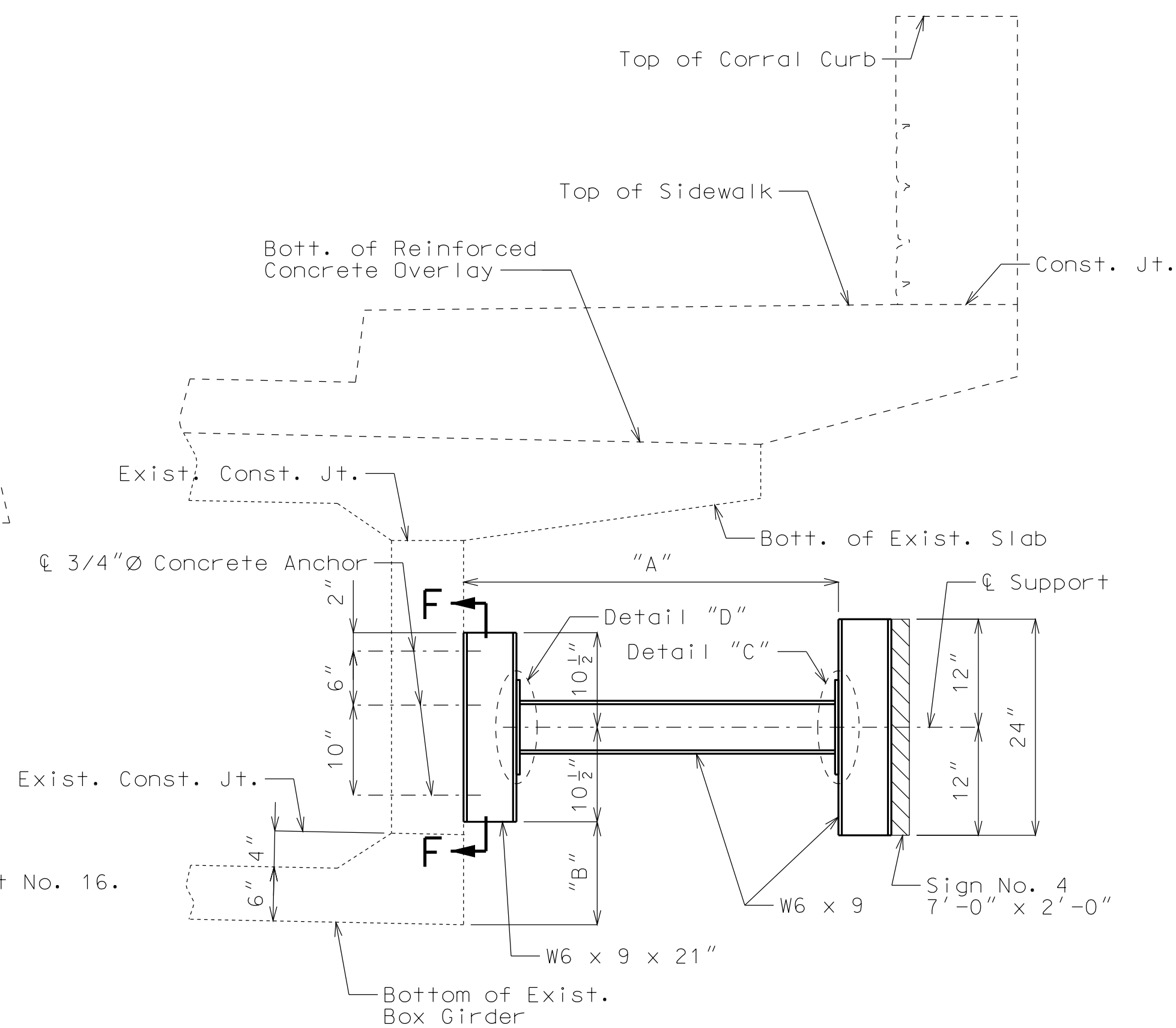

SECTION J-J

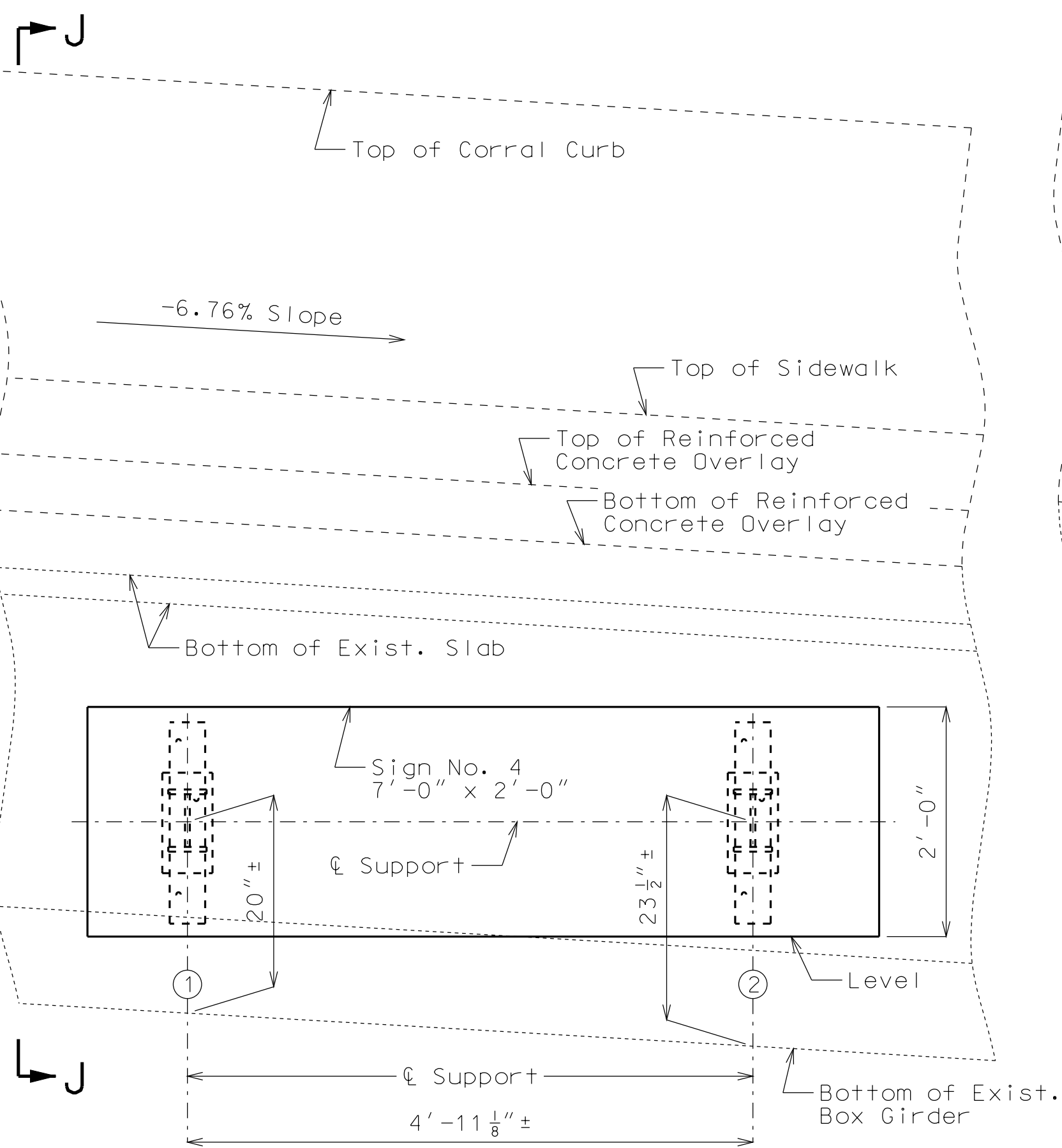

ELEVATION H-H (Sign No. 4)

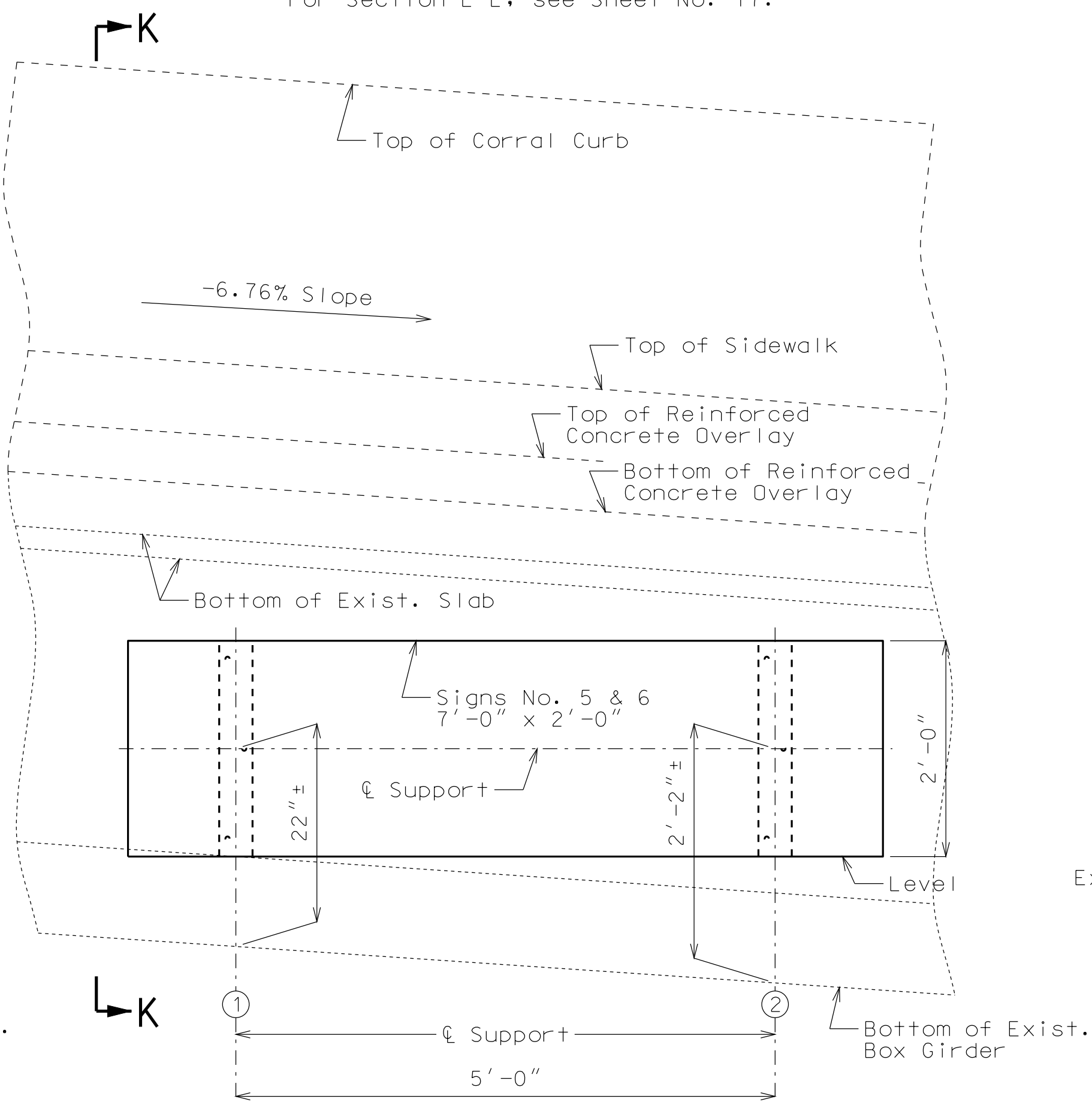

ELEVATION I-I (Signs No. 5 & 6)

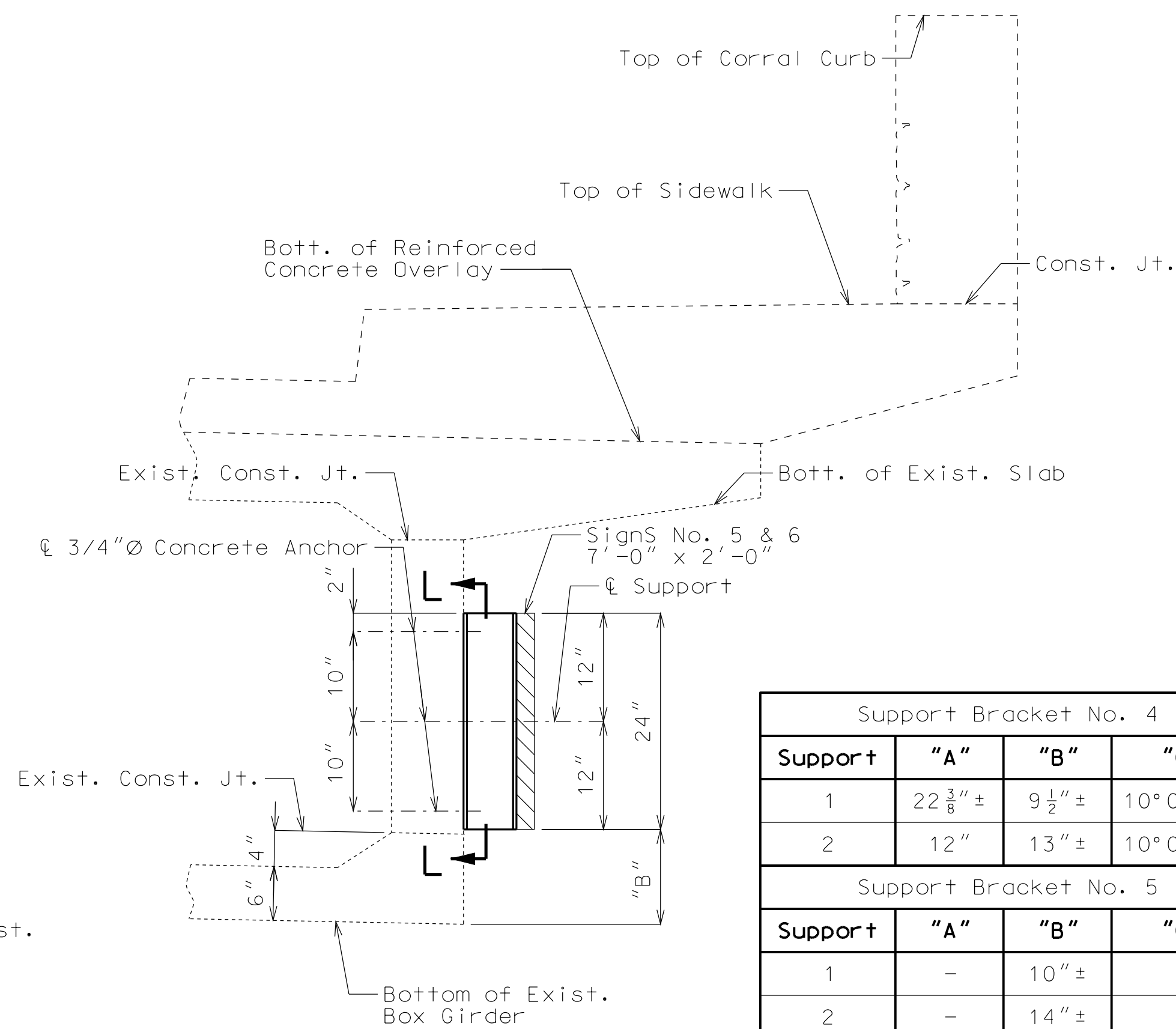

SECTION K-K

Support Bracket No. 4			
Support	"A"	"B"	"C"
1	22 3/8" ±	9 1/2" ±	10° 0' 0" ±
2	12"	13" ±	10° 0' 0" ±
Support Bracket No. 5			
Support	"A"	"B"	"C"
1	-	10" ±	-
2	-	14" ±	-
Support Bracket No. 6			
Support	"A"	"B"	"C"
1	-	10" ±	-
2	-	14" ±	-

"THIS MEDIA SHOULD NOT BE CONSIDERED A CERTIFIED DOCUMENT."

DATE PREPARED
1/22/2014
ROUTE I-670 STATE MO
DISTRICT BR SHEET NO. 18
COUNTY JACKSON
JOB NO. J412023
CONTRACT ID.
PROJECT NO.
BRIDGE NO. A08073

DESCRIPTION	DATE

MISSOURI HIGHWAYS AND TRANSPORTATION COMMISSION
MoDOT
105 WEST CAPITOL
JEFFERSON CITY, MO 65102
1-888-ASK-MODOT (1-888-275-6636)

MISSOURI STATE HIGHWAY DEPARTMENT

FED. ROAD DIST. NO.	STATE	FEDERAL PROJ. NO.	B SEC.	FISCAL YEAR	SHEET NO.	TOTAL SHEETS
5	MO.				37	
DIST. NO.	COUNTY	ROUTE	SEC.			
4						

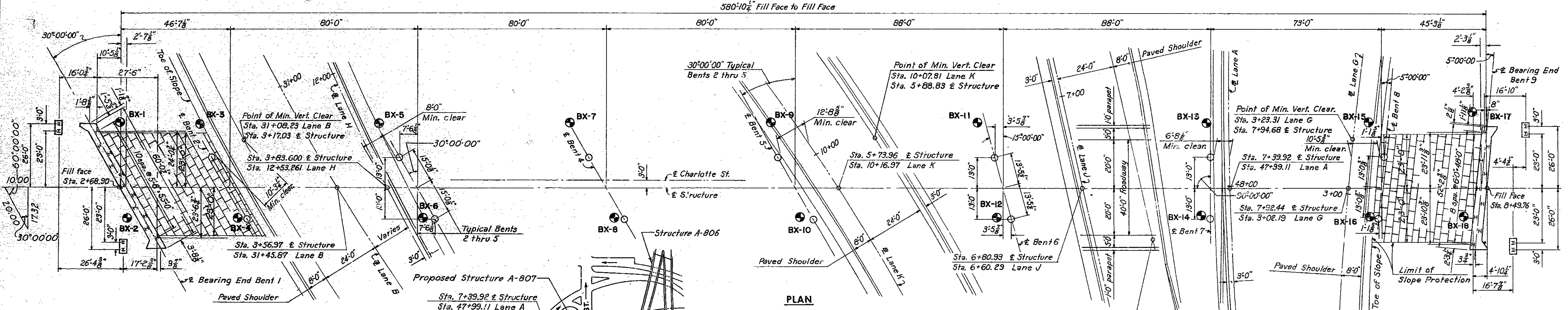
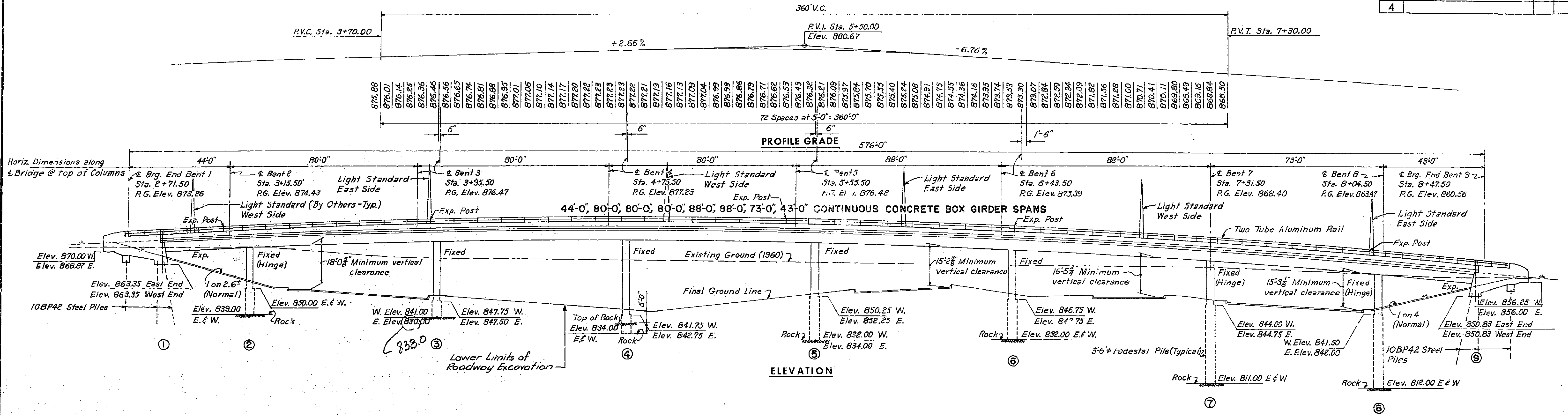

BENCH MARK:
 Bench Mark No. 5-X cut on S. Bolt Top of Hydrant N.W. Corner Truman Rd. & Charlotte Elev. 856.19

HOWARD, NEEDLES, TAMMEN & BERGENDOFF
 CONSULTING ENGINEERS
 KANSAS CITY NEW YORK

MADE RGP DATE 10-27-60 TRACED DATE
 CHECKED JLV DATE 11-25-60 SCALE

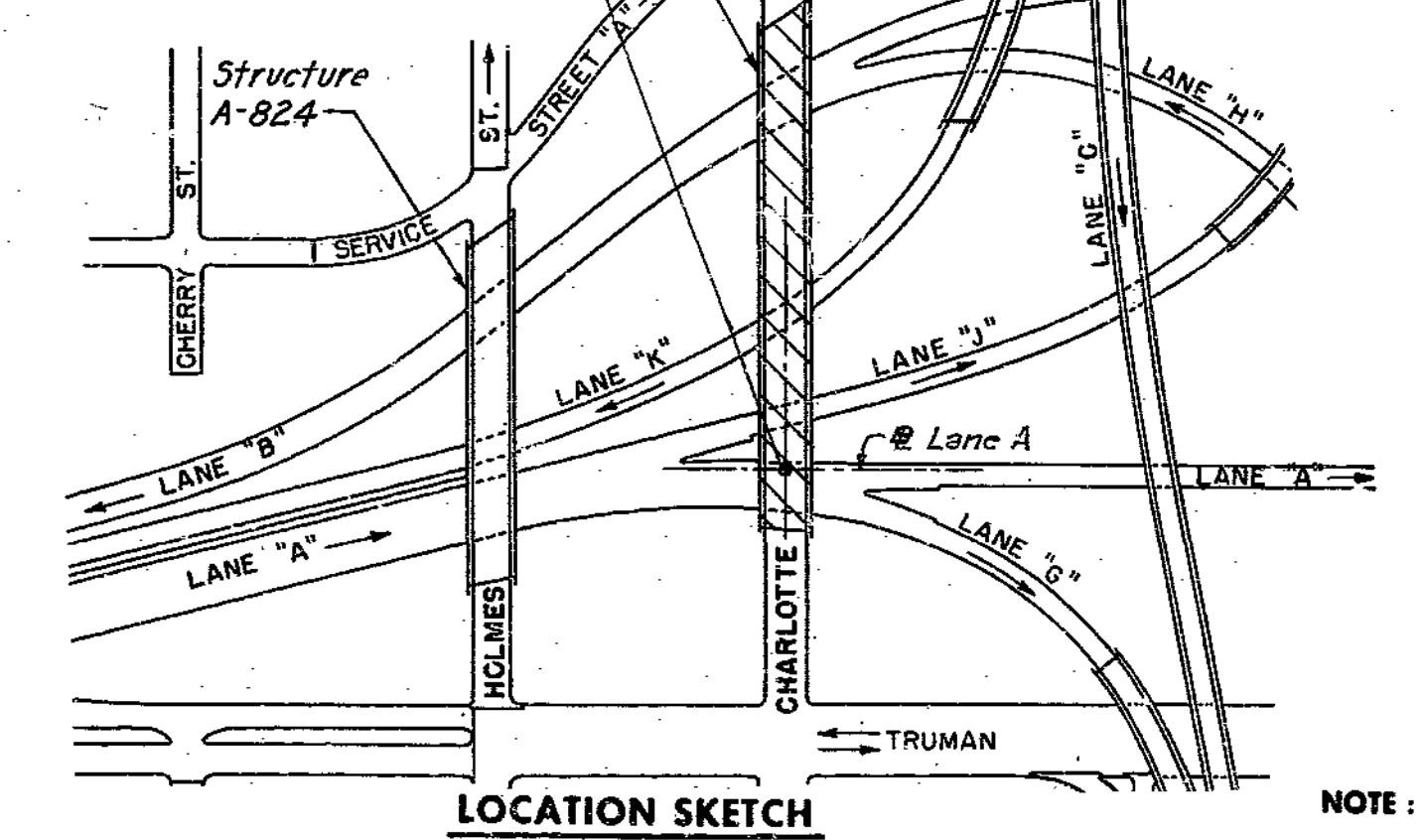

Notes:
 Concrete slope protection to be included under roadway contract. For details see sheet 16.
 Location of borings are marked thus BX-12.
 For boring logs see sheet 2.

SUBMITTED BY: *[Signature]*
 REGISTERED PROFESSIONAL ENGINEER
 MISSOURI NO. E-253

BRIDGE: CHARLOTTE STREET UNDERPASS
 CROSSTOWN FREEWAY
 KANSAS CITY, MO.
 PROJECT NO. I-70-1 (41) (RT. I-70) STA. 47+99.11
JACKSON COUNTY
 LANE A

SUBMITTED BY: *[Signature]* DATE 7/6/61
 BRIDGE ENGINEER

APPROVED BY: *[Signature]* DATE 7/6/61
 CHIEF ENGINEER

STD 54.00
 A-307

NOTE: This drawing is not to scale. Follow dimensions.

GENERAL PLAN AND ELEVATION

SHEET 1 OF 18

SEE PLAN LANS BROWN LINES

BROWN LINES

MISSOURI STATE HIGHWAY DEPARTMENT

FED. ROAD DIST. NO.	STATE	FEDERAL PROJECT NO. & SEC.	FISCAL YEAR	SHEET NO.	TOTAL SHEETS
4	MO.			38	
		COUNTY			

GENERAL NOTES

Design Specifications: A.A.S.H.O. 1957 with tentative revisions for 1958 and 1959.

Design Loading: H 20-S16-44 and alternate loading designated in P.P.M. 20-4 Sec. 4c. 15 #/sq. ft. future wearing surface.

Concrete: Concrete stress: Class B1 $f_c = 1,600$ psi
Class B $f_c = 1,200$ psi
Concrete for superstructure shall be Class B1 air-entrained. Concrete for pedestal piles and end bents shall be Class B air-entrained.

Reinforcing Steel: Allowable stress 20,000 p.s.i. All splices in reinforcing steel shall be 32 bar diameters. Bar sizes are designated on the plans by numbers. The first digit after the letter in three digit marks and the first two digits after the letter in four digit marks indicate the size of the bar.
Dimensions shown on the plans from the reinforcing steel to outside edge of concrete are all clear dimensions.
All bending dimensions are from "out to out" of bars.

Joint Filler: Where joint filler is specified on the plans it shall conform with the requirements for gray sponge rubber compound joints as given in Section 157.2.4 of the Standard Specifications.

Piling: All piles shall conform with details and notes on Sheet No. 16. All piles required for this structure will be furnished by the State. (See special provisions). All piles shall be driven to or into solid rock, boulders, shale or cemented gravel, or to not less than full length authorized, and to sustain a load of at least 37 tons per pile for 10 SP42.
All piles shall be driven with a power hammer. See section 52.47 of Standard Specifications, for required painting of steel piles.

Steel Conduits: Expansion sleeves shall be required in steel conduit at all expansion joints. Expansion fittings shall be O.Z. Electrical Manufacturing Company type AX 125 with AJ bonding jumper or equal.

Welding: Qualification of welding operators will be required.

Sealing of Decks: Superstructure deck to be surface sealed. See Special Provisions.

Utilities: All utilities, unless shown otherwise, shall be removed or relocated by others. The Contractor will notify the owner of the utilities of his work schedule sufficiently in advance to allow time for the disposition of utilities.

Shipping: Permits must be obtained for all truck loads over legal length.

Excavation to Rock: All loose, shelly or disintegrated rock shall be removed and pedestal piles placed on hard, solid, undisturbed rock. If soft rock or shale is encountered the pedestal piles shall be carried at least 18" into and cast against vertical faces of same. In no case shall the pedestal piles be placed higher than elevations shown. The Maximum Ultimate Presumptive Bearing Values of 10 Tons per sq. ft. for firm or hard shale and 50 Tons per sq. ft. for firm or unweathered limestone was used in design of pedestal piles.

ESTIMATED QUANTITIES				
ITEM	UNIT	SUB-STRUCTURE	SUPER-STRUCTURE	TOTAL
Class 1 Excavation, for Structures	Cu. Yd.	195		195
42" ϕ Pedestal Pile	Lin. Ft.	248.0		248.0
Steel Piles in Place (State Furnished 10BP42)	Lin. Ft.	625		625
Class B Concrete (Substructure)	Cu. Yd.	140.1		140.1
Class B1 Concrete	Cu. Yd.		2,015.8	2,015.8
Reinforcing Steel	Lbs.	36,650	626,050	662,700
Fabricated Structural Carbon Steel	Lbs.		11,620	11,620
Bridge Rail (Two Tube Type)	Lin. Ft.		1,208	1,208
Conduit System (On Structure)	L.S.			1
Conduit System for Kansas City Power and Light Company	L.S.			1

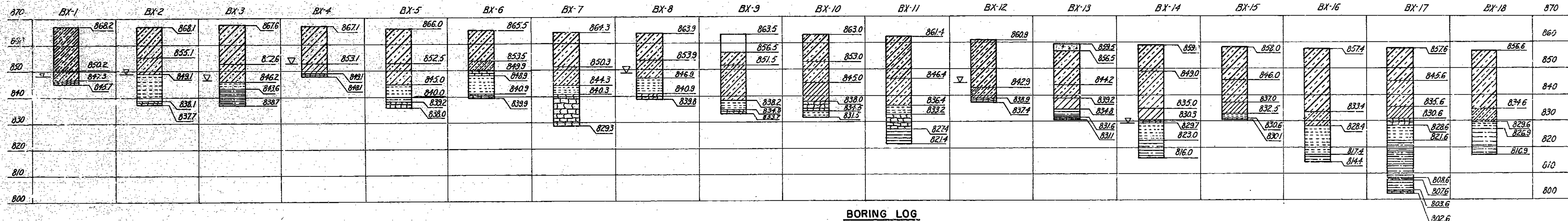

BORING LOG

Quantity Notes

Estimated quantity of Class B concrete substructure includes all concrete in end bents. All other concrete, except in pedestal piles, is included in estimated quantity of Class B1 concrete superstructure.
All excavation for bridge will be paid for as Class 1 Excavation for Structures. Sketches show limits of excavation for tax purposes.
All concrete and reinforcement above top of pedestal piles at intermediate bents is included in superstructure quantities.
Reinforcement in pedestal piles is included in substructure quantities.
Weight of bearings is included in weight of fabricated structural carbon steel.
No payment will be made for excavation below tops of pedestal piles of intermediate bents.

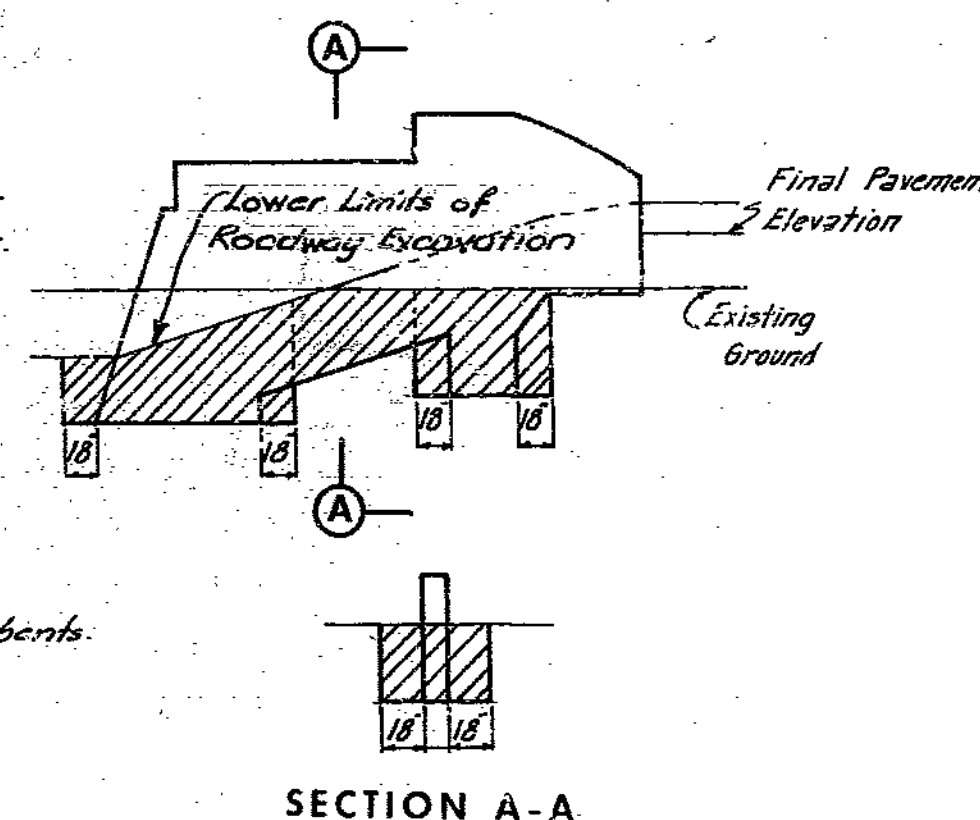

SECTION A-A

	Fill		Shale
	Concrete		Weathered Shale
	Silty Loam		
	Silty Clay		
	Weathered Limestone		
	Westerville Limestone		
	Clay		

BORING LEGEND

NOTES:

Top elevation of boring is existing ground surface.
All borings are augered, except BX-6, BX-7, BX-11 and BX-18 which are cored.
Bottom elevations of BX-11, BX-14, BX-16 and BX-18 are in shale. Bottom elevations of BX-6 and BX-7 are in limestone. All other bottom elevations are top of limestone refusal.
For location of borings see sheet 1.
▽ designates water level.

BRIDGE: CHARLOTTE STREET UNDERPASS
CROSSTOWN FREEWAY
KANSAS CITY, MO.

PROJECT NO. 1-70-1 (41) (RT. I-70)

STA. 47+99.11
LANE A

JACKSON COUNTY

SHEET 2 OF 18

A-807

HOWARD, NEEDLES, TAMMEN & BERGENDOFF
CONSULTING ENGINEERS
KANSAS CITY, MISSOURI
NEW YORK, NEW YORK

MADE BY RVS DATE 11-16-60 TRACED DATE
CHECKED JAB E J W DATE 11-25-60 SCALE

NOTE: This drawing is not to scale. Follow dimensions.

GENERAL NOTES

REAL PLANS (10-200) LINES

Table with project details: DIST. NO. 5 MO., COUNTY, ROUTE 39, SHEET 39 OF 39.

BILL OF REINFORCEMENT table for substructure end bent 1, listing items H401 through H424 with dimensions.

BILL OF REINFORCEMENT table for substructure end bent 9, listing items V501 through V560 with dimensions.

BILL OF REINFORCEMENT table for substructure bent 2, listing items H601 through H695 with dimensions.

BILL OF REINFORCEMENT table for substructure bent 3, listing items F421 through F1132 with dimensions.

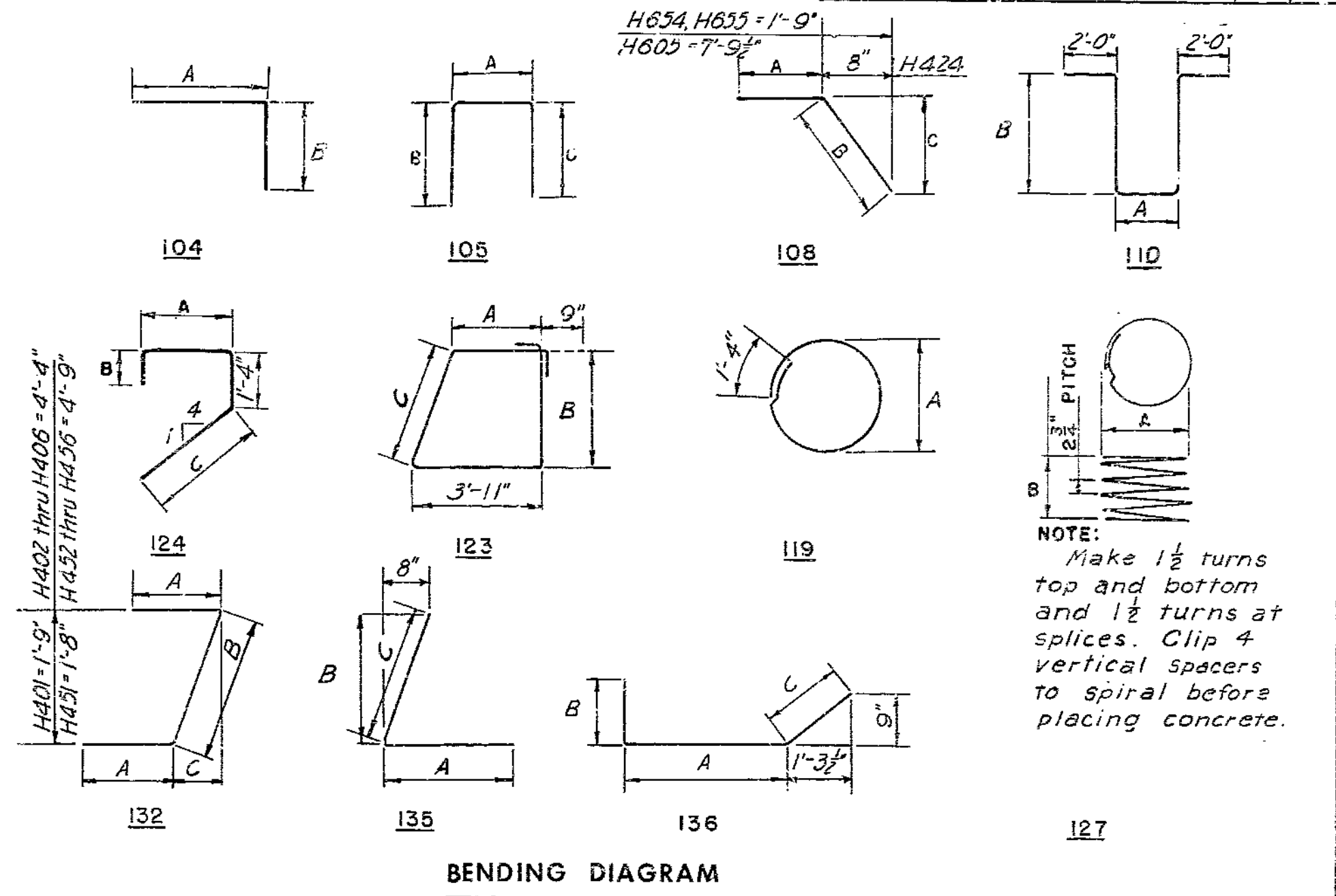

BILL OF REINFORCEMENT table for superstructure bents 2, 3, 4, 5, 6, 7, 8, listing items C421 through C482 with dimensions.

Note: Hooks and bends shall be in accordance with ACI Manual of Standard Practice for Detailing Reinforced Concrete Structures (ACI-315-57)

BRIDGE : CHARLOTTE STREET UNDERPASS
CROSSTOWN FREEWAY
KANSAS CITY, MO.
PROJECT NO. I-70-1 (41) (RT. I-70) STA. 47+99.11
JACKSON COUNTY LANE A
SHEET 3 OF 18 A-507

HOWARD, NEEDLES, TAMMEN & BERGENDOFF CONSULTING ENGINEERS KANSAS CITY NEW YORK
MADE BY RVS DATE 11-18-60 TRACED DATE
CHECKED JPS DATE 11-22-60 SCALE

* May be Field bent

MISSOURI STATE HIGHWAY DEPARTMENT

5	MO.	40
4	COUNTY	ROUTE SEC.

BILL OF REINFORCEMENT						
NO.	MARK	LENGTH	SHAPE	DIMENSIONS		
				A	B	C
SUPERSTRUCTURE						
328	B601	11'-9 1/2"	110	2'-7 1/2"	4'-0"	7"
16	B602	48'-1"	5tr.			
4	B603	43'-1"	5tr.			
8	B604	41'-8"	5tr.			
72	B605	11'-5"	110	2'-3"	4'-0"	7"
144	B606	11'-6 1/2"	110	2'-4"	4'-0"	7"
Substructure						
24	B1101	5'-5"	5tr.			
28	B1102	20'-0"	↑			
36	B1103	11'-6"	↑			
6	B1104	48'-10"	↑			
8	B1105	18'-8"	↑			
12	B1106	47'-2"	↑			
4	B1107	18'-3"	↑			
24	B1108	48'-1"	↑			
16	B1109	24'-0"	↑			
16	B1110	21'-0"	↑			
14	B1111	15'-0"	↑			
6	B1112	43'-1"	↑			
4	B1113	21'-8"	↑			
4	B1114	19'-0"	↑			
4	B1115	13'-6"	↑			
12	B1116	41'-8"	↑			
8	B1117	20'-10"	↑			
8	B1118	18'-4"	↑			
2	B1119	13'-0"	5tr.			
288	D501	10'-5"	109	5"	4'-0 1/2"	9"
24	D502	11'-5"	109	11"	4'-0 1/2"	9"
26	D601	48'-1"	5tr.			
10	D602	3'-1"	5tr.			
42	D603	18'-10"	109	1'-4 1/2"	4'-2"	0-10 1/2"
4	D604	16'-9"	109	1'-4 1/2"	6'-1 1/2"	0-10 1/2"
6	D605	41'-8"	5tr.			
10	D606	21'-0"	5tr.			
38	D607	12'-4"	123	1'-2"	4'-2"	4'-1"
8	D608	15'-8"	123	1'-2"	5'-10"	5'-9"
12	D609	43'-1"	5tr.			
16	D610	41'-8"	5tr.			
4	D611	15'-11"	109	1'-4 1/2"	5'-8 1/2"	10 1/2"
24	D612	8'-7"	100	7'-3"	8"	
12	D801	10'-3"	108	2'-3"	8'-0"	11"
Substructure						
12	G401	27'-2"	5tr.			
24	G402	28'-2"	↑			
60	G403	22'-0"	↑			
316	G404	28'-0"	↑			
16	G405	30'-0"	↑			
12	G406	29'-6"	↑			
16	G407	28'-11"	↑			
48	G408	21'-2"	↑			
12	G409	20'-11"	↑			
32	G410	24'-4"	↑			
24	G411	22'-4"	↑			
12	G412	18'-0"	↑			
36	G413	28'-3"	↑			
36	G414	23'-7"	↑			
4	G415	22'-5"	↓			
12	G416	17'-8"	5tr.			
6917	G501	6'-2"	129	4'-2 1/2"	1'-0"	1 1/2"
1123	G502	6'-2"	105	4'-2 1/2"	1'-0"	1 1/2"
Substructure						
14	G801	20'-4"	5tr.			
36	G802	52'-8"	↑			
42	G803	32'-8"	↑			
8	G804	47'-8"	↑			
26	G805	22'-6"	↑			
2	G806	17'-0"	↑			
4	G807	43'-2"	↑			
4	G808	41'-0"	↑			
4	G809	39'-0"	↑			
4	G810	37'-0"	↑			
4	G811	35'-0"	5tr.			
Substructure						
14	G1101	34'-0"	5tr.			
28	G1102	25'-0"	↑			
42	G1103	18'-0"	↑			
91	G1104	12'-0"	↑			
43	G1105	37'-0"	↓			
16	G1106	29'-0"	5tr.			

BILL OF REINFORCEMENT						
NO.	MARK	LENGTH	SHAPE	DIMENSIONS		
				A	B	C
14	G1107	23'-0"	5tr.			
28	G1108	16'-0"	↑			
28	G1109	33'-0"	↑			
30	G1110	28'-0"	↑			
46	G1111	20'-0"	↑			
19	G1112	40'-0"	↑			
45	G1113	33'-0"	↑			
56	G1114	26'-0"	↑			
14	G1115	14'-0"	↑			
16	G1116	44'-0"	↑			
14	G1117	30'-0"	↑			
14	G1118	24'-0"	↑			
30	G1119	41'-0"	↑			
30	G1120	19'-0"	↑			
245	G1121	60'-0"	↑			
42	G1122	27'-4"	↑			
4	G1123	22'-2"	↑			
4	G1124	31'-8"	↑			
2	G1125	41'-9"	↑			
2	G1126	20'-4"	↑			
4	G1127	37'-6"	↑			
4	G1128	35'-4"	↑			
4	G1129	33'-6"	↑			
2	G1130	21'-0"	↑			
2	G1131	39'-0"	↑			
20	G1132	27'-0"	↑			
10	G1133	34'-3"	↑			
2	G1134	50'-0"	↑			
2	G1135	40'-7"	↑			
24	G1136	48'-0"	↑			
2	G1137	32'-0"	↑			
14	G1138	45'-6"	↑			
2	G1139	46'-4"	↑			
11	G1140	31'-0"	↑			
14	G1141	26'-3"	↑			
10	G1142	47'-3"	↑			
10	G1143	32'-9"	↑			
8	G1144	51'-0"	↑			
11	G1145	47'-0"	↑			
14	G1146	49'-0"	↑			
14	G1147	35'-0"	↑			
20	G1148	46'-0"	↑			
27	G1149	58'-0"	5tr.			
Substructure						
198	S401	16'-4"	5tr.			
155	S402	30'-0"	↑			
71	S403	28'-4"	↑			
26	S404	17'-4"	↑			
78	S405	19'-4"	↑			
60	S406	20'-10"	↑			
28	S407	13'-1"	↑			
540	S408	24'-6"	↑			
43	S409	9'-4"	↑			
80	S410	15'-4"	↑			
184	S411	24'-4"	↑			
69	S412	21'-4"	↑			
24	S413	8'-4"	↑			
10	S414	14'-3"	↑			
4	S415	6'-1"	↑			
30	S416	26'-7"	↑			
30	S417	27'-2"	↑			
52	S418	20'-6"	↑			
30	S419	18'-4"	↑			
40	S420	21'-0"	↑			
2	S421	25'-7"	↑			
77	S422	25'-0"	↑			
38	S423	22'-5"	↑			
30	S424	23'-6"	↑			
28	S425	23'-0"	↑			
30	S426	23'-2"	↑			
4	S427	20'-0"	↑			
30	S428	23'-3"	↑			
15	S429	27'-5"	↑			
12	S430	21'-0"	↑			
26	S431	26'-10"	↓			
41	S432	27'-10"	5tr.			
Substructure						
12	S501	27'-0"	5tr.			
12	S502	30'-10"	5tr.			
91	S503	7'-0"	5tr.			
50	S504	28'-1"	5tr.			

BILL OF REINFORCEMENT						
NO.	MARK	LENGTH	SHAPE	DIMENSIONS		
				A	B	C
954	S504	21'-0"	5tr.			
40	S505	26'-0"	↑			
65	S506	33'-0"	↑			
901	S507	27'-10"	↑			
52	S508	37'-10"	↑			
3	S509	30'-2"	↑			
5	S510	25'-0"	↑			
6	S511	37'-1"	↑			
9	S512	29'-10"	↑			
5	S513	30'-4"	↑			
9	S514	28'-4"	↑			
6	S515	33'-2"	↑			
6	S516	28'-0"	↑			
50	S517	27'-10"	↑			
548	S518	22'-0"	109	1'-3"	2'-3"	7 1/2"
65	S519	29'-6"	↑			
48	S520	25'-10"	↑			
40	S521	33'-9"	↑			
914	S522	24'-0"	↑			
5	S523	27'-10"	↑			
5	S524	33'-6"	↑			
6	S525	34'-0"	↑			
9	S526	38'-11"	↑			
4	S527	29'-0"	↑			
6	S528	24'-6"	↑			
12	S529	27'-4"	↑			
2	S530	7'-6"	↑			
1	S531	14'-3"	↑			
1	S532	16'-0"	↑			
6	S533	24'-10"	5tr.			
12	S534	4'-2"	104	2'-2"	2'-0"	
24	S535	23'-10"	5tr.			
573	S536	20'-0"	↑			
554	S537	23'-8"	↑			
5	S538	25'-0"	↑			
14	S539	28'-2"	↑			
20	S540	15'-10"	↑			
8	S541	21'-6"	↑			
20	S542	23'-0"	↑			
13	S543	20'-6"	↑			
12	S544	29'-9"	↑			
6	S545	26'-0"	↑			
18	S546	22'-6"	↑			
7	S547	27'-0"	↑			
12	S548	24'-6"	↑			
4	S549	4'-6"	↑		</	

MISSOURI STATE HIGHWAY DEPARTMENT

DIST. NO.	STATE FEDERAL PROJECT NO. & SEC.	SCALE	YEAR	NO.	TOTAL SHEETS
5	MO.			4	
4	COUNTY	ROUTE	SEC.		

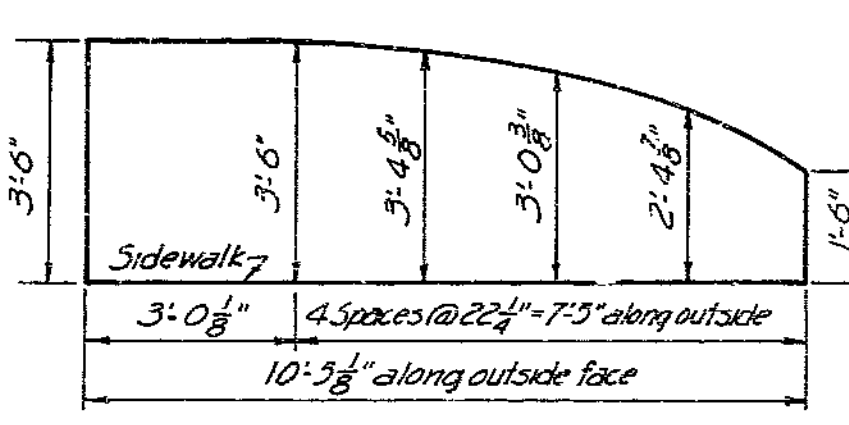
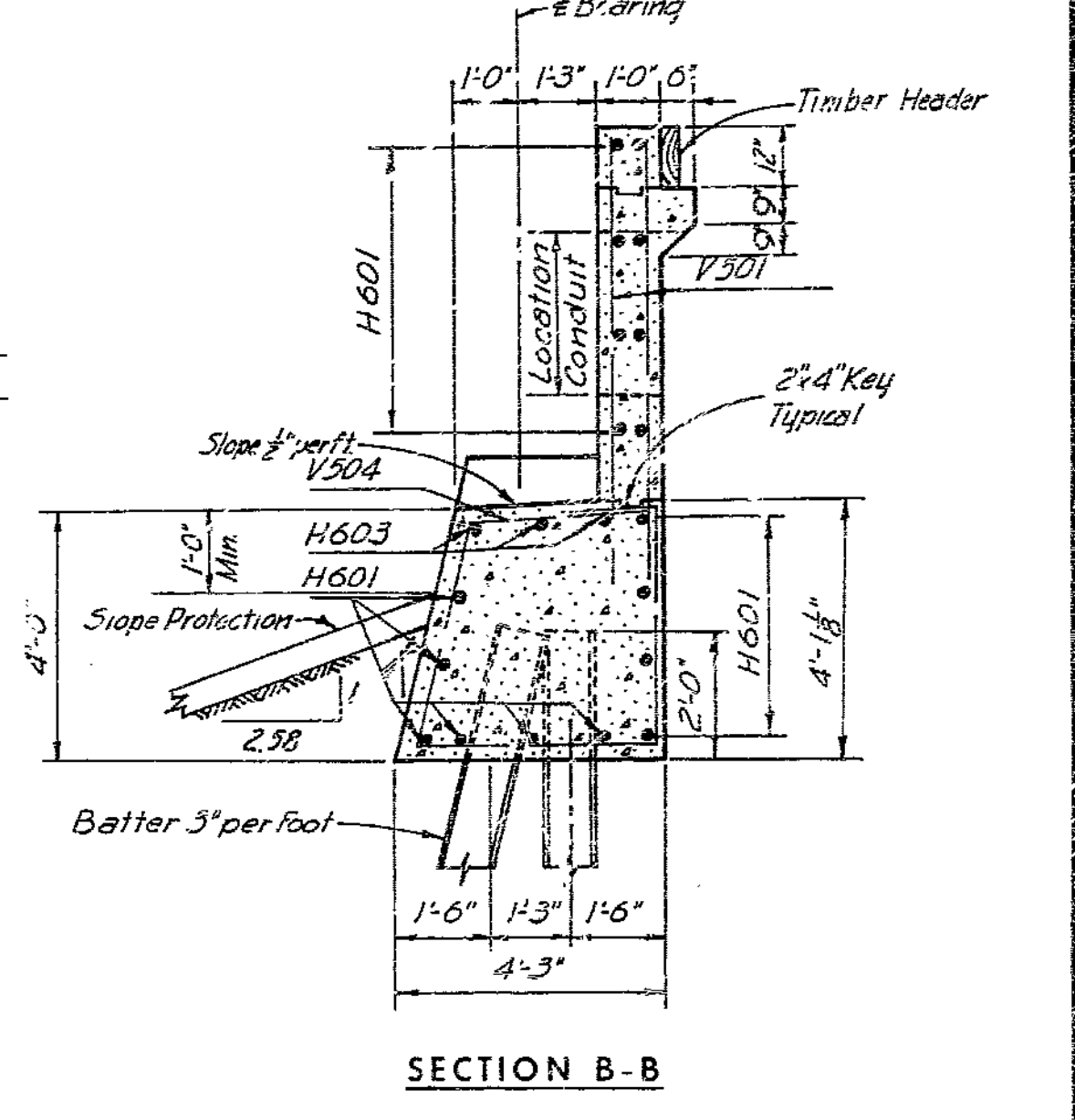
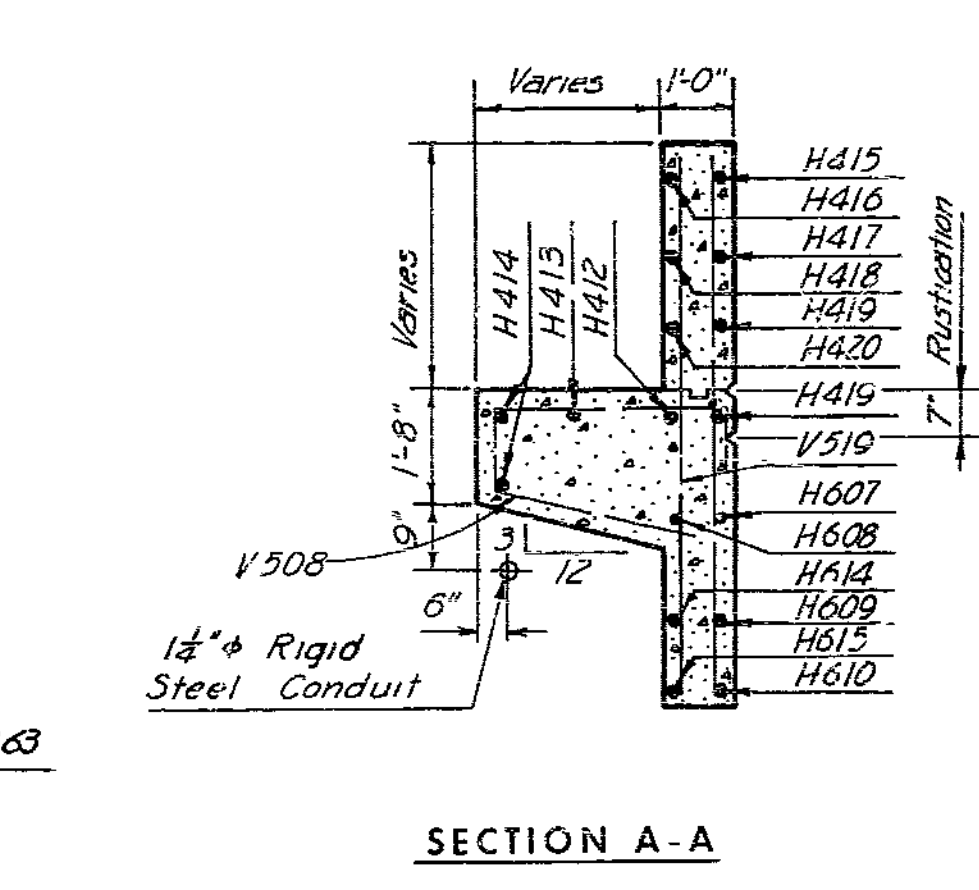
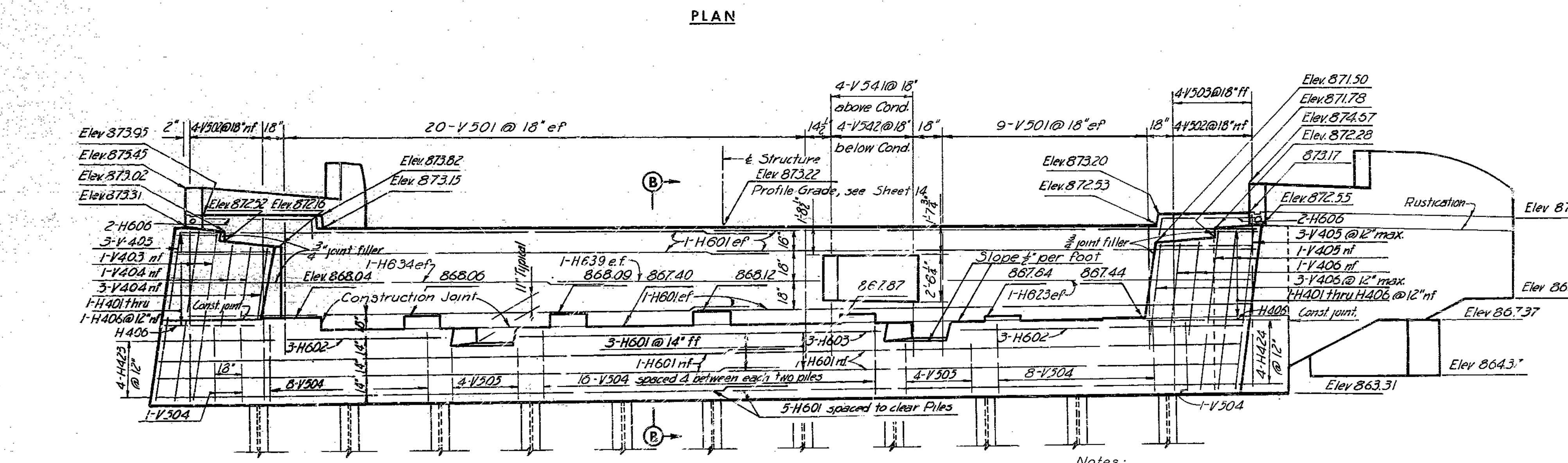
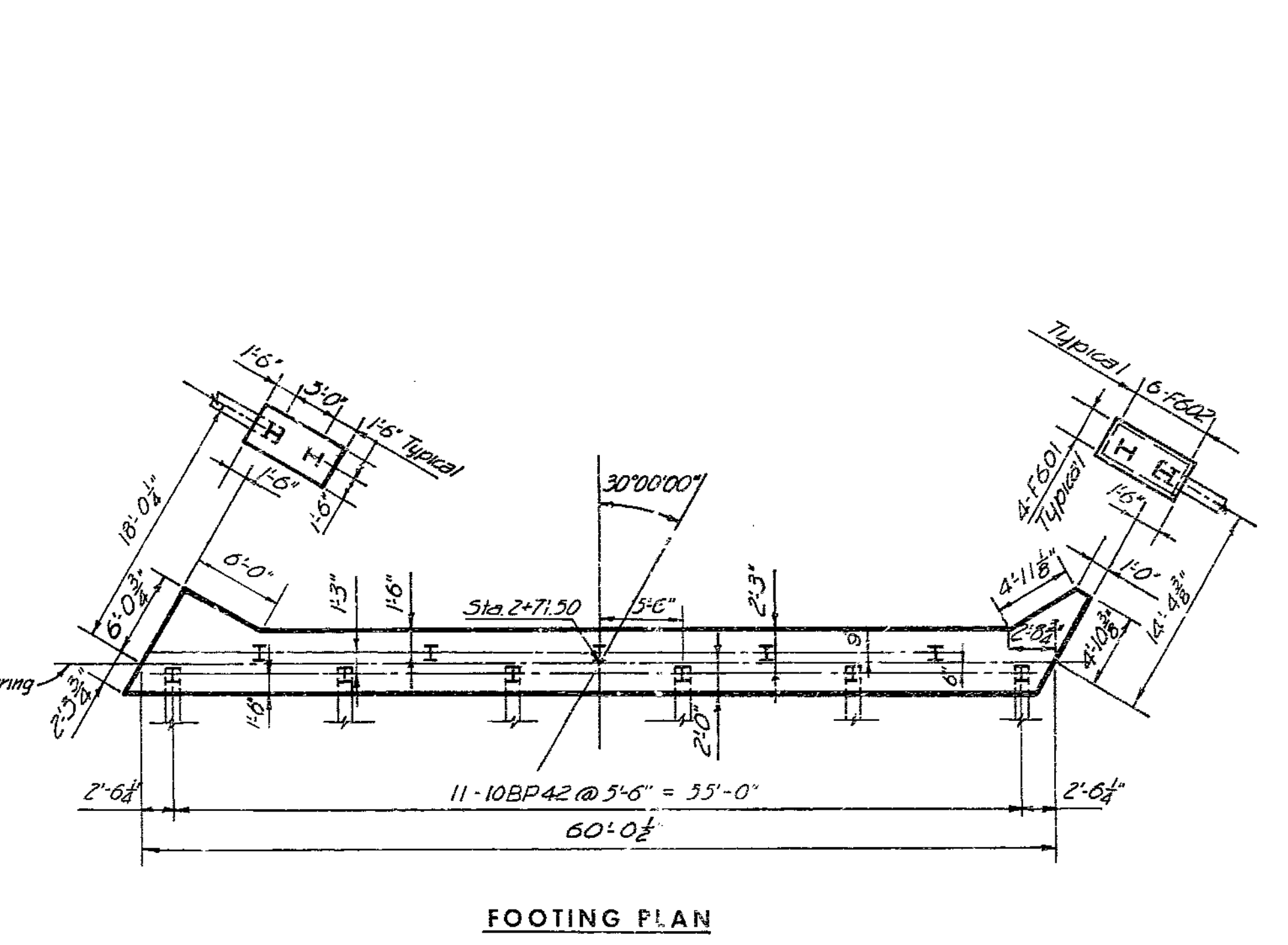
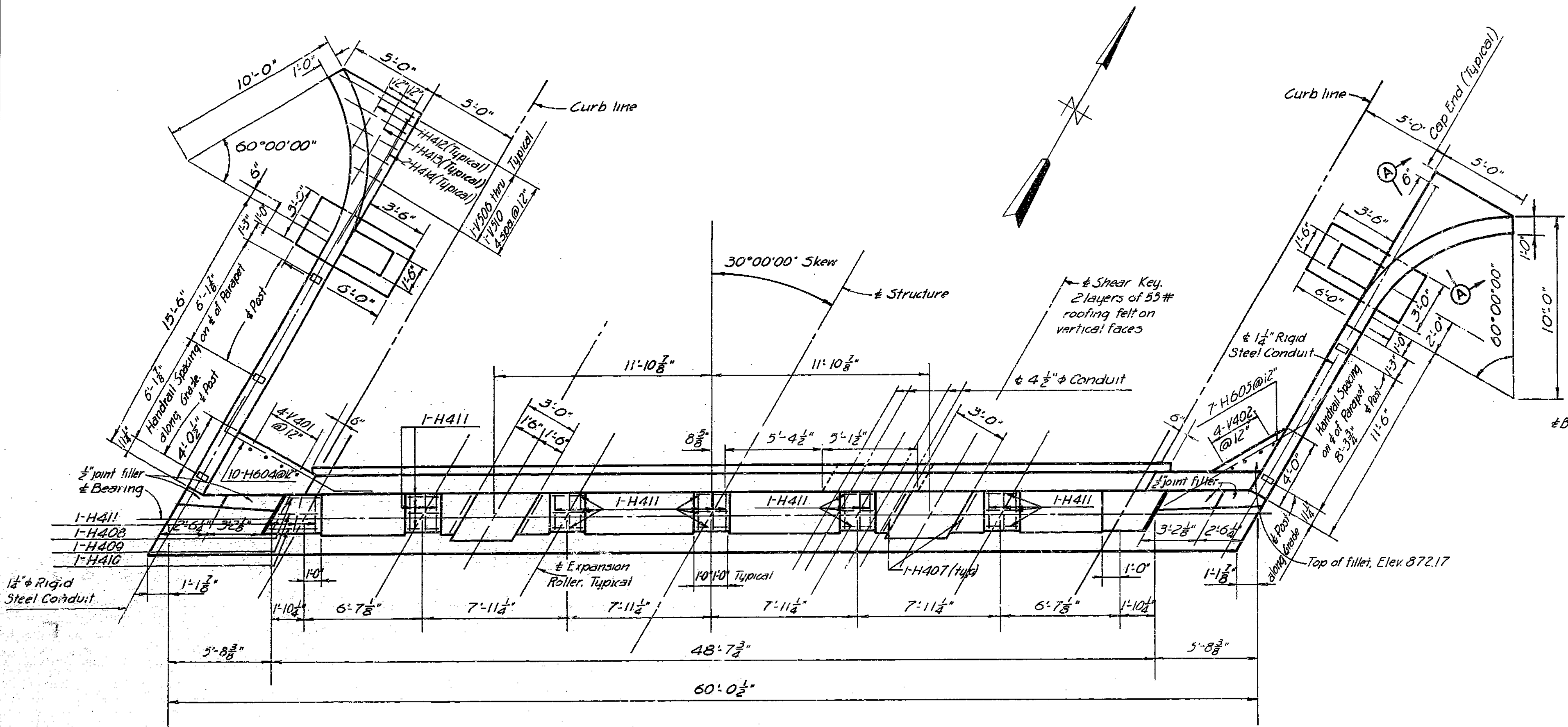

Notes:
 Piles shall be 10BP 42 battered 3" per foot where shown.
 All Barrel and Mask Wall Elevations are given at the Front Face of the Backwall.
 All Dimensions and Elevations are given to the Face of the Concrete.
 Concrete Cover on Reinforcing Steel shall be 2" unless otherwise shown.
 For Wingwall details, see sheet 8.
 For Pile splice, Shear key, and Rustication details see sheet 16.

Legend:
 nf = Near face
 ff = Far face
 ef = Each face

NOTE: This drawing is not to scale. Follow dimensions.

END BENT I

HOWARD, NEEDLES, TAMMEN & BERGENDOFF CONSULTING ENGINEERS

MADE	DATE	TRACED	DATE
JABIK	10-28-60		
CHECKED	DATE	SCALE	
JPS	11-22-60		

BRIDGE : CHARLOTTE STREET UNDERPASS
 CROSSTOWN FREEWAY
 KANSAS CITY, MO.
 PROJECT NO. I-70-1 (41) (RT. I-70) STA. 47+99.11
 JACKSON COUNTY
 LANE A

SHEET 5 OF 18

A-807

MISSOURI STATE HIGHWAY DEPARTMENT

FED. ROAD DIST. NO.	STATE	FEDERAL PROJECT NO. & SEC.	FISCAL YEAR	SHEET NO.	TOTAL SHEETS
5	MO.			42	
DIST. NO.	COUNTY	ROUTE	SEC.		
4					

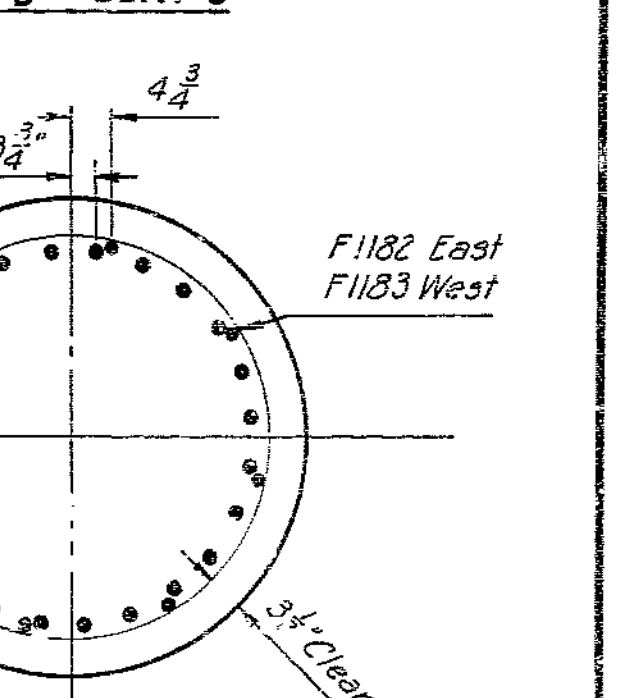
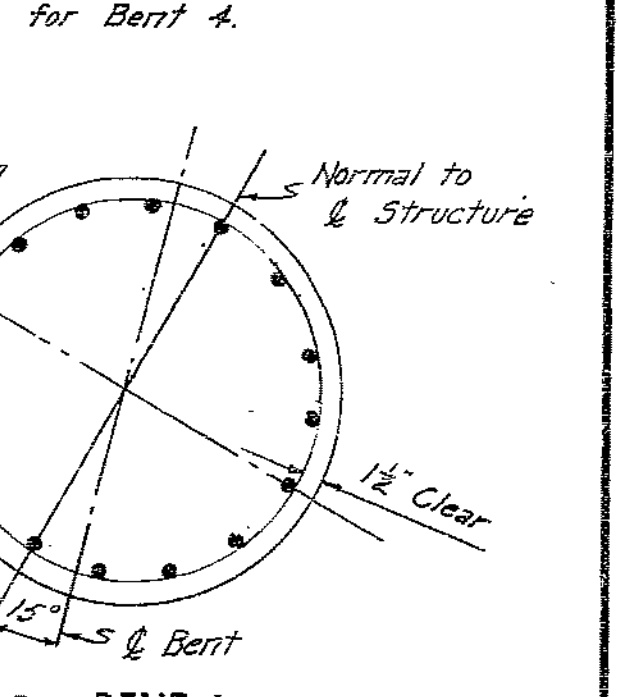
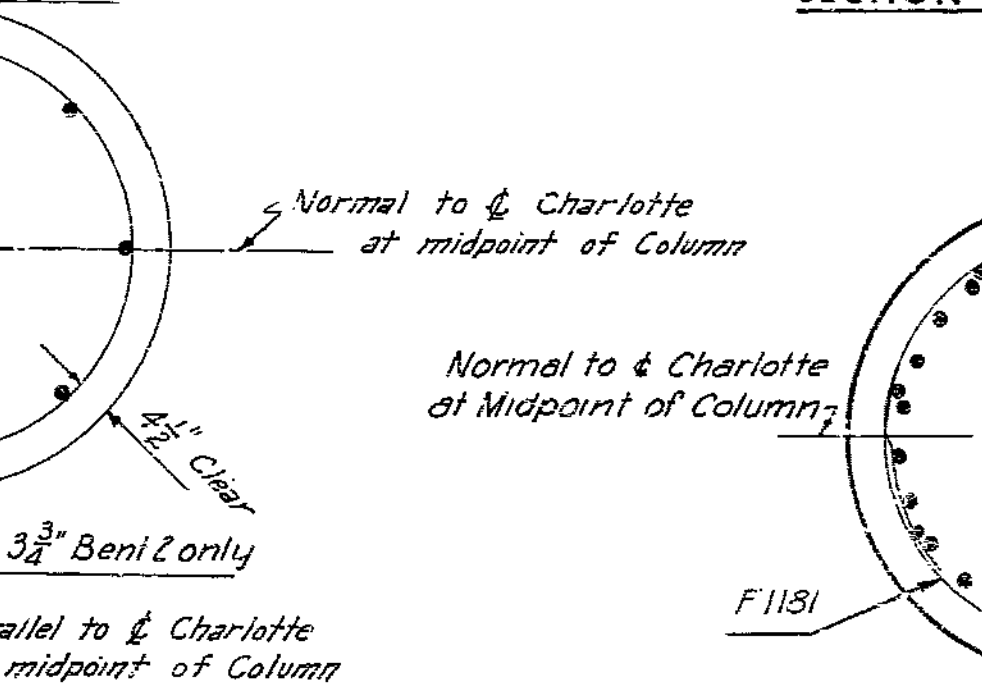
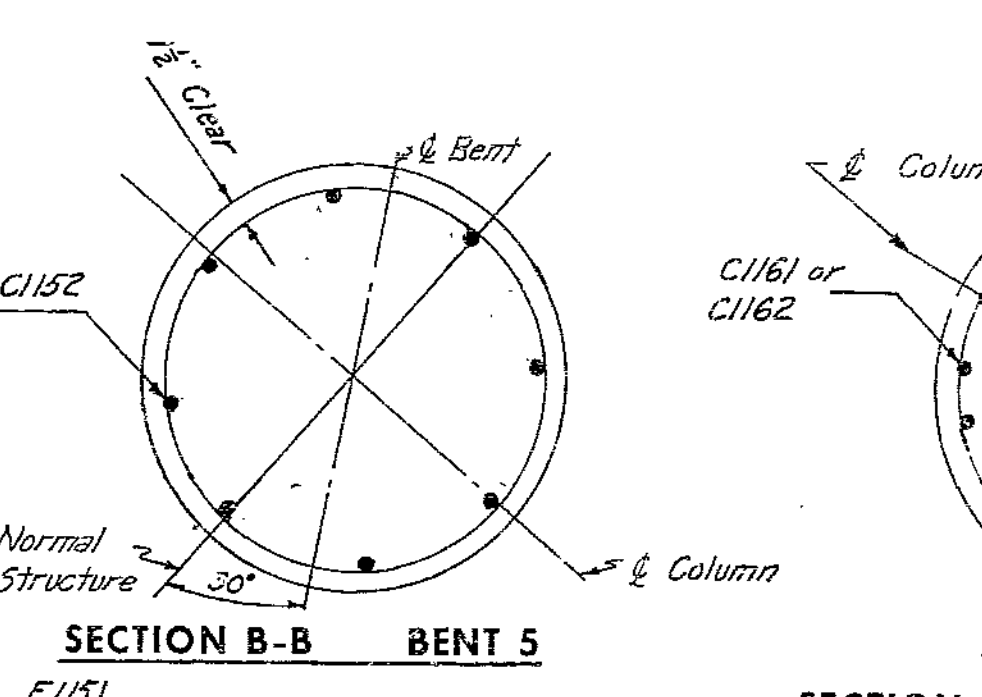
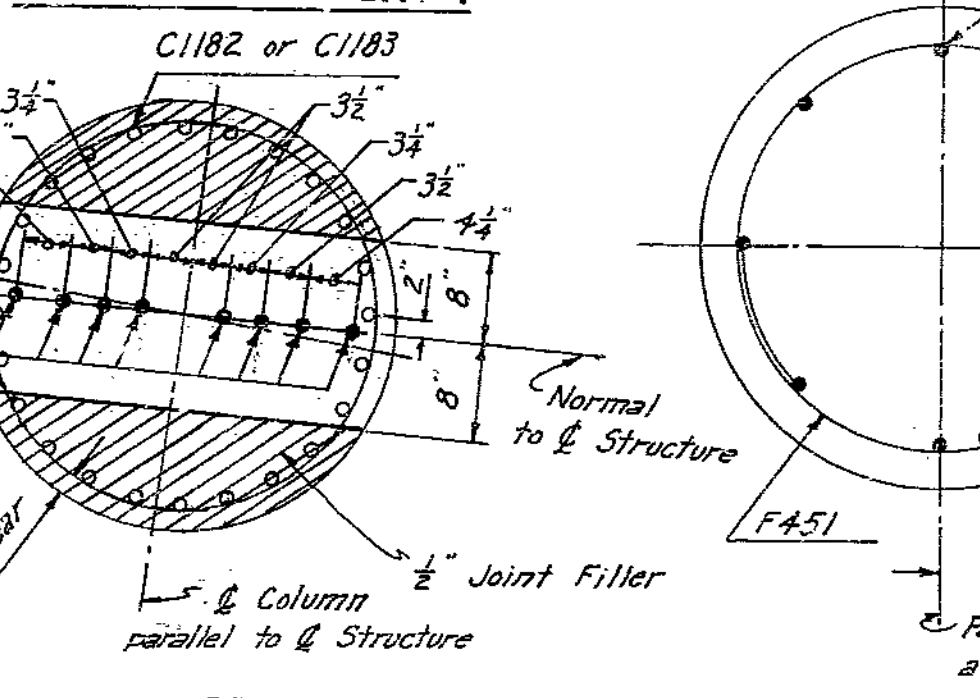
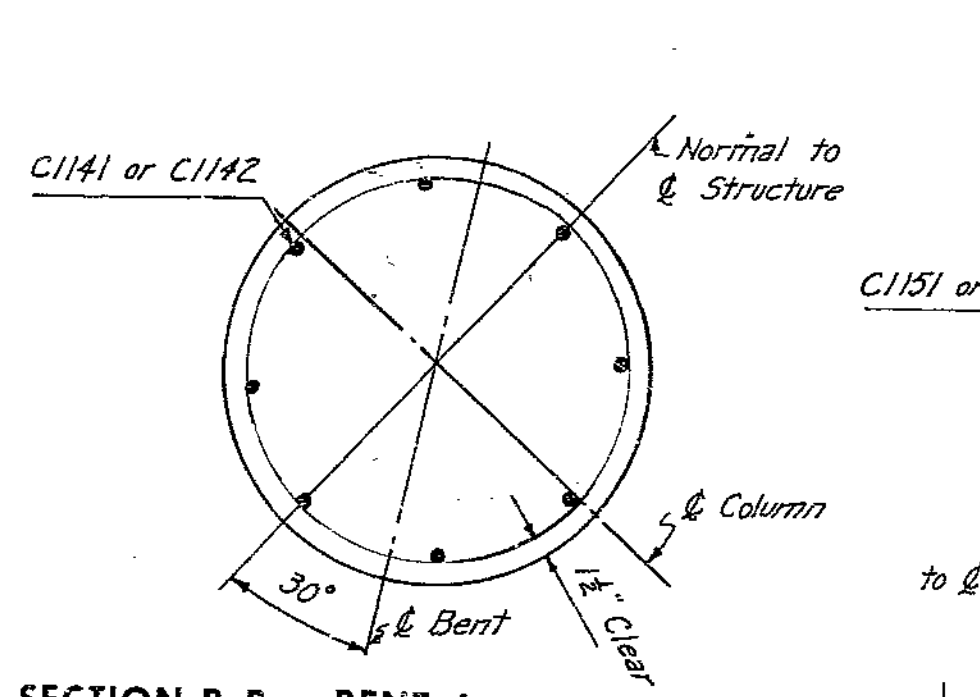
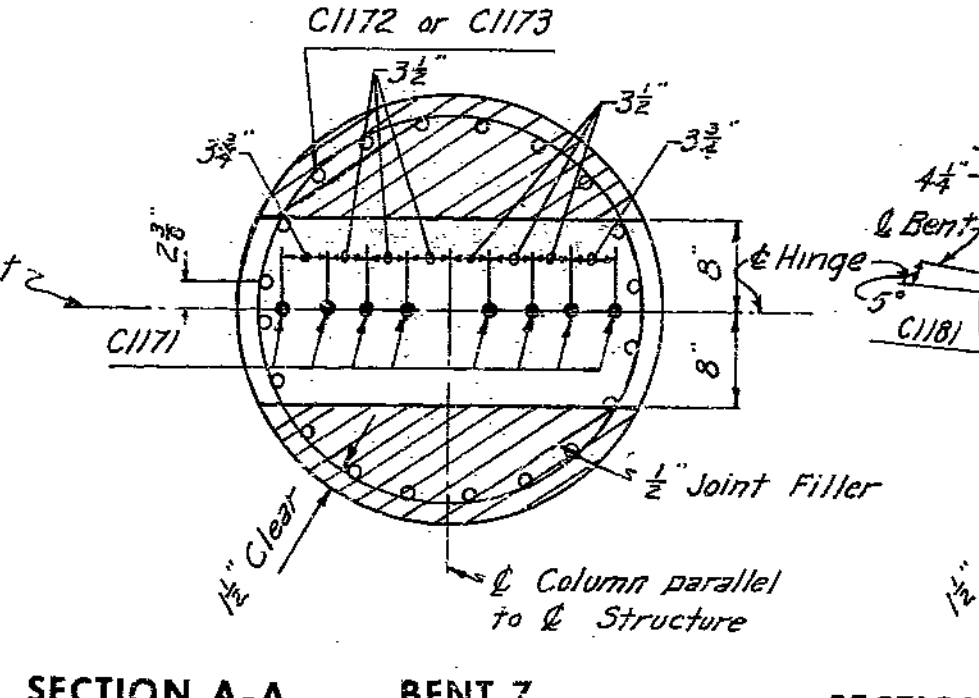
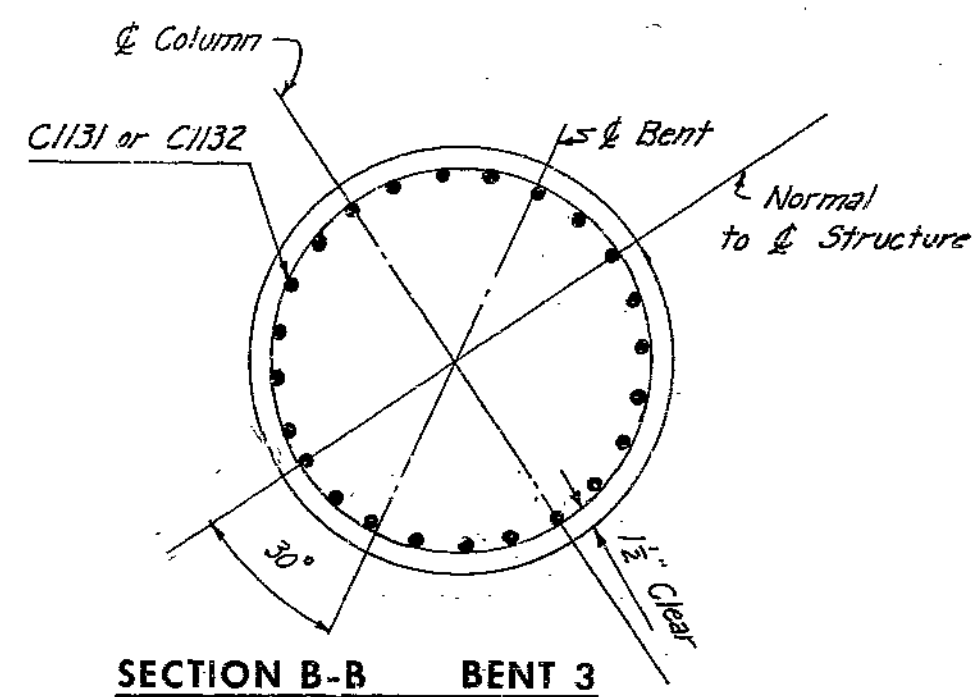
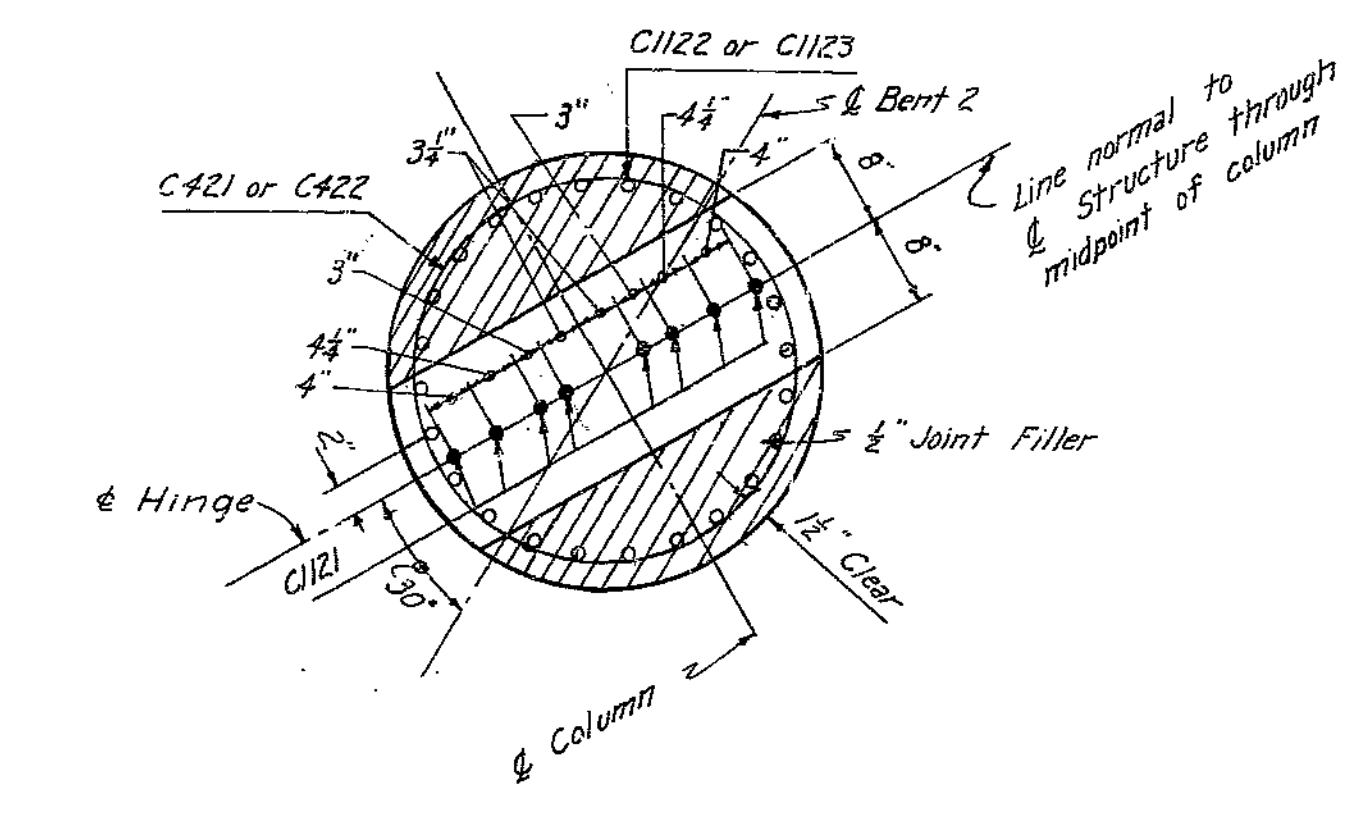
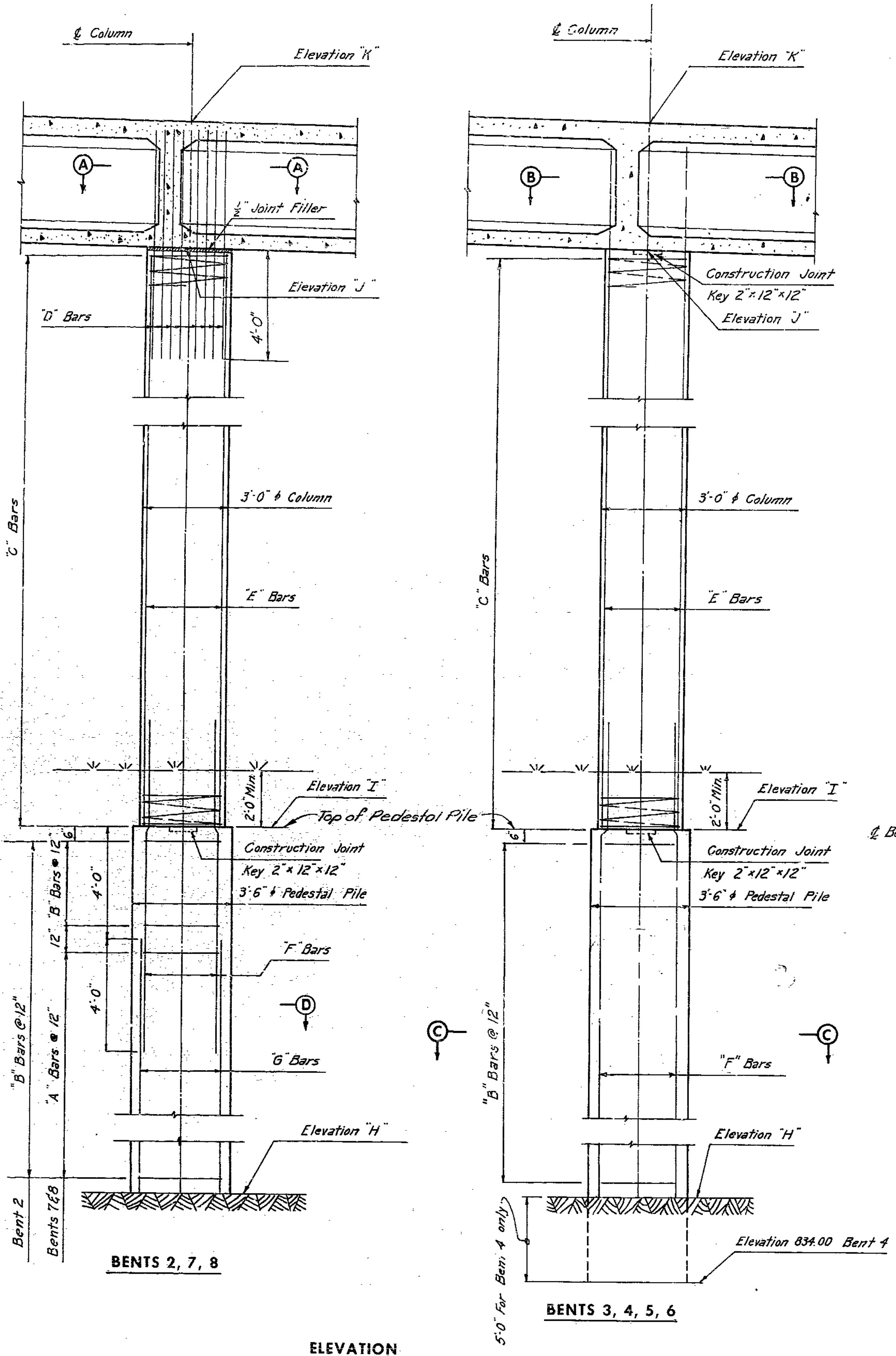
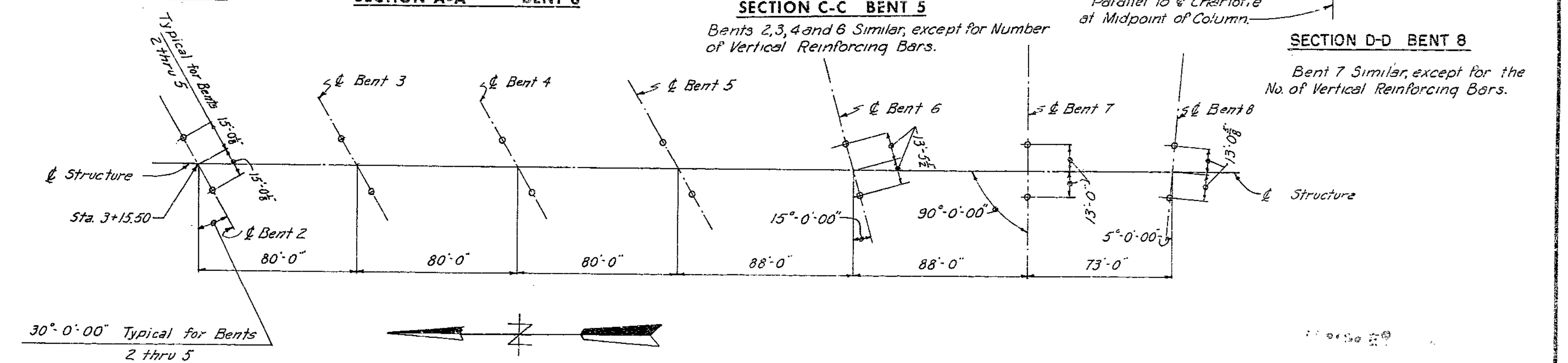

TABLE OF REINFORCING AND ELEVATIONS

Cols.	A Bars	B Bars	C Bars	D Bars	E Bars	F Bars	G Bars	L Bars	H Elev	I Elev	J Elev	K Elev
2E			1-C421	8-C1121	24-C1122	24-F1121			839.00	850.00	869.49	873.99
2W		11-F421	1-C422	8-C1121	24-C1123	24-F1121			839.00	850.00	869.89	874.39
7E	30-F471	4-F472	1-C471	8-C1171	20-C1172	20-F1171	8-F1172		811.00	844.75	863.65	868.16
7W	29-F471	4-F472	1-C472	8-C1171	20-C1173	20-F1171	8-F1173		811.00	844.00	863.65	868.16
8E	26-F481	4-F482	1-C481	8-C1181	24-C1182	24-F1181	8-F1182		812.00	842.00	858.65	863.16
8W	26-F481	4-F482	1-C482	8-C1181	24-C1183	24-F1181	8-F1183		812.00	841.50	858.79	863.30
3E		10-F431	1-C431		24-C1131	24-F1131			839.00	847.50	871.59	876.03
3W		7-F431	1-C432		24-C1132	24-F1132			841.00	847.75	871.88	876.38
4E		9-F441	1-C441		8-C1141	8-F1141			*	842.75	872.49	876.99
4W		8-F441	1-C442		8-C1142	8-F1142			*	841.75	872.48	876.98
5E		18-F451	1-C451		8-C1151	8-F1151			834.00	852.25	871.73	876.23
5W		18-F451	1-C452		8-C1152	8-F1151			832.00	850.25	871.40	875.90
6E		16-F461	1-C461		16-C1161	16-F1161			832.00	847.75	868.78	873.28
6W		15-F461	1-C462		16-C1162	16-F1162			832.00	846.75	868.47	872.97

* Take bottom of shaft 5'-0" below top of limestone for Bent 4.



HOWARD, NEEDLES, TAMMEN & BERGENDOFF
CONSULTING ENGINEERS
KANSAS CITY NEW YORK
MADE RVS DATE 10-27-60 TRACED DATE
CHECKED JPS DATE 11-22-60 SCALE

NOTE: This drawing is not to scale. Follow dimensions.

BENTS 2, 3, 4, 5, 6, 7 AND 8

BRIDGE : CHARLOTTE STREET UNDERPASS
CROSSTOWN FREEWAY
KANSAS CITY, MO.
PROJECT NO. I-70-1 (41) (RT. I-70) STA. 47+99.11
BLANE A
JACKSON COUNTY
SHEET 6 OF 18
A-807

SEE FINAL PLANS BROWN-LINES

MISSOURI STATE HIGHWAY DEPARTMENT

FED. ROAD DIST. NO.	STATE	FEDERAL PROJECT NO. & SEC.	FISCAL YEAR	SHEET NO.	TOTAL SHEETS
5	MO.			43	
DIST. NO.	COUNTY				
4					

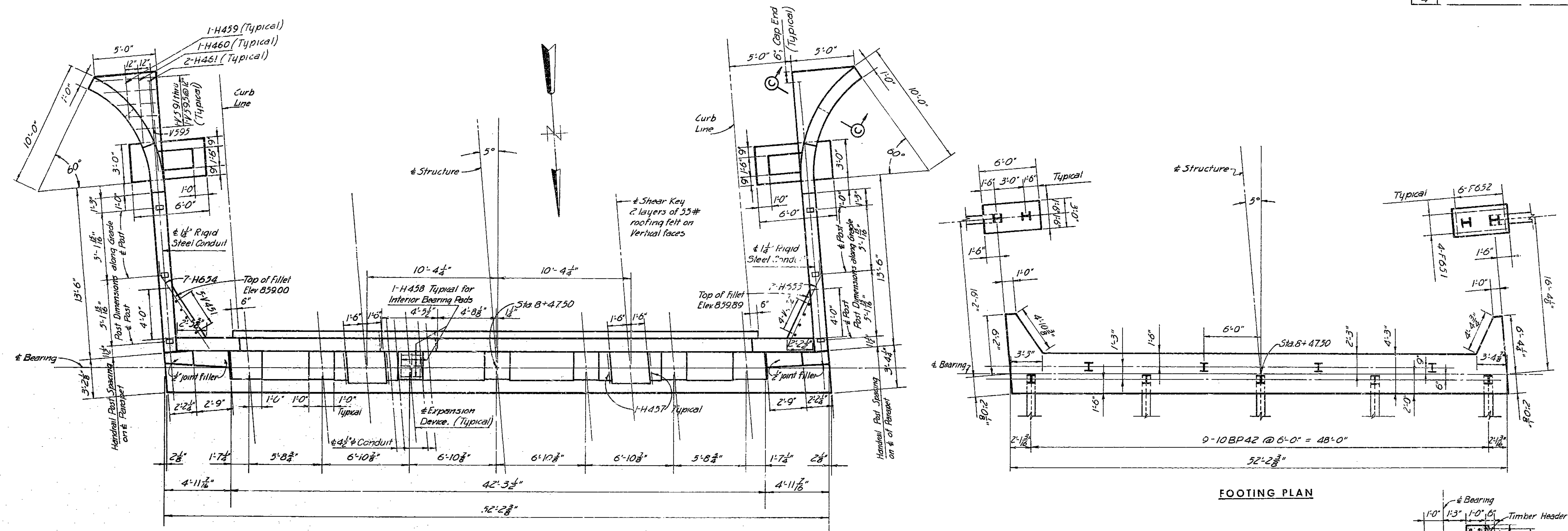

PLAN

FOOTING PLAN

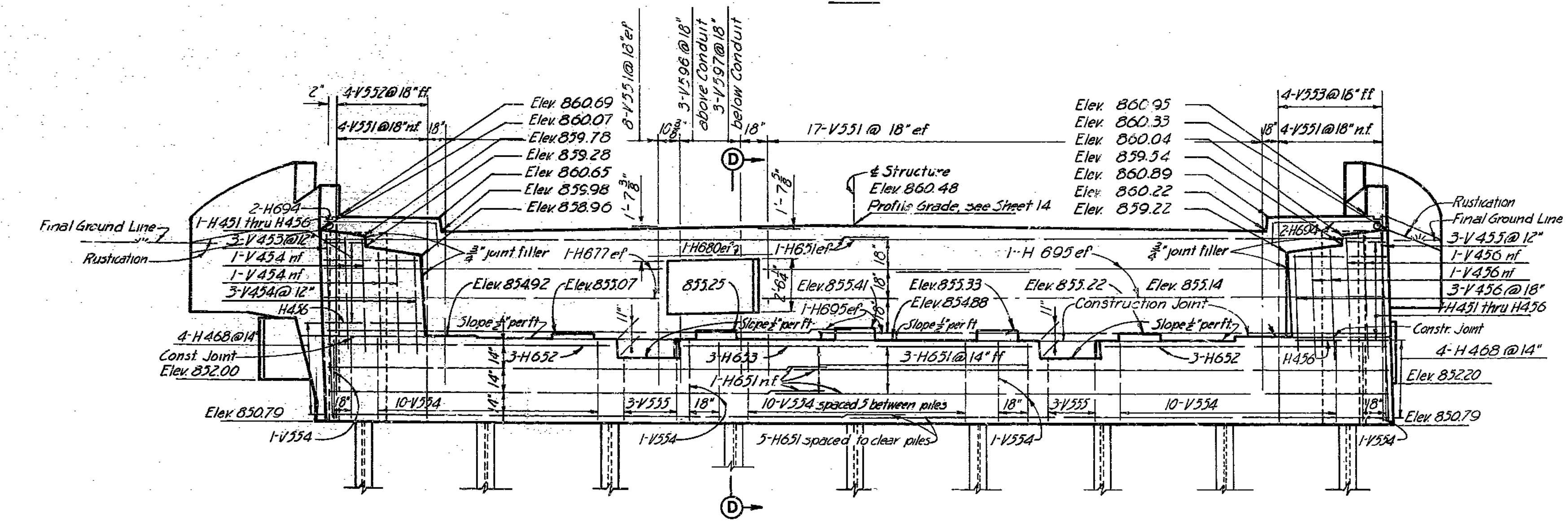

ELEVATION

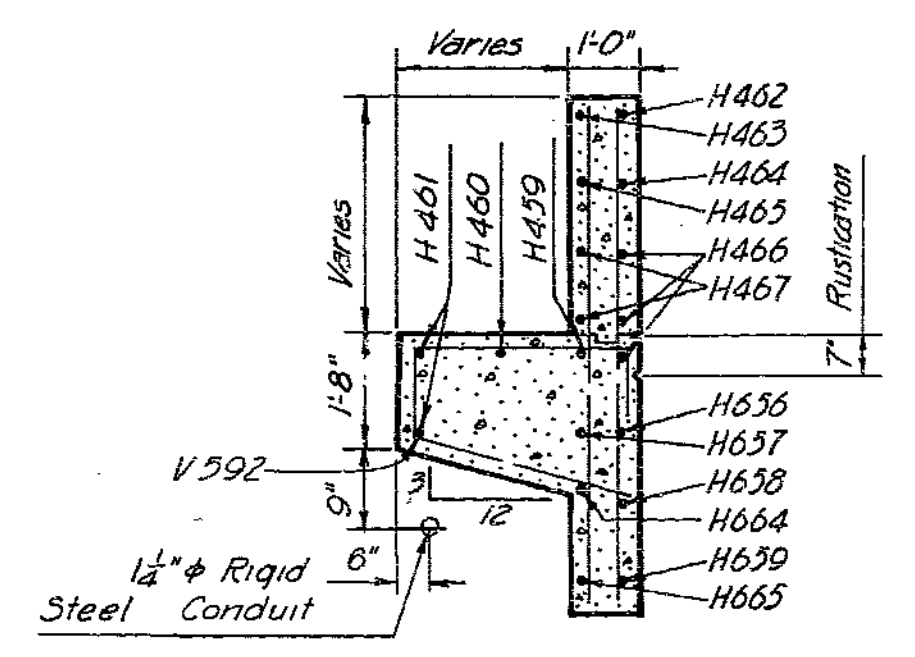

SECTION C-C

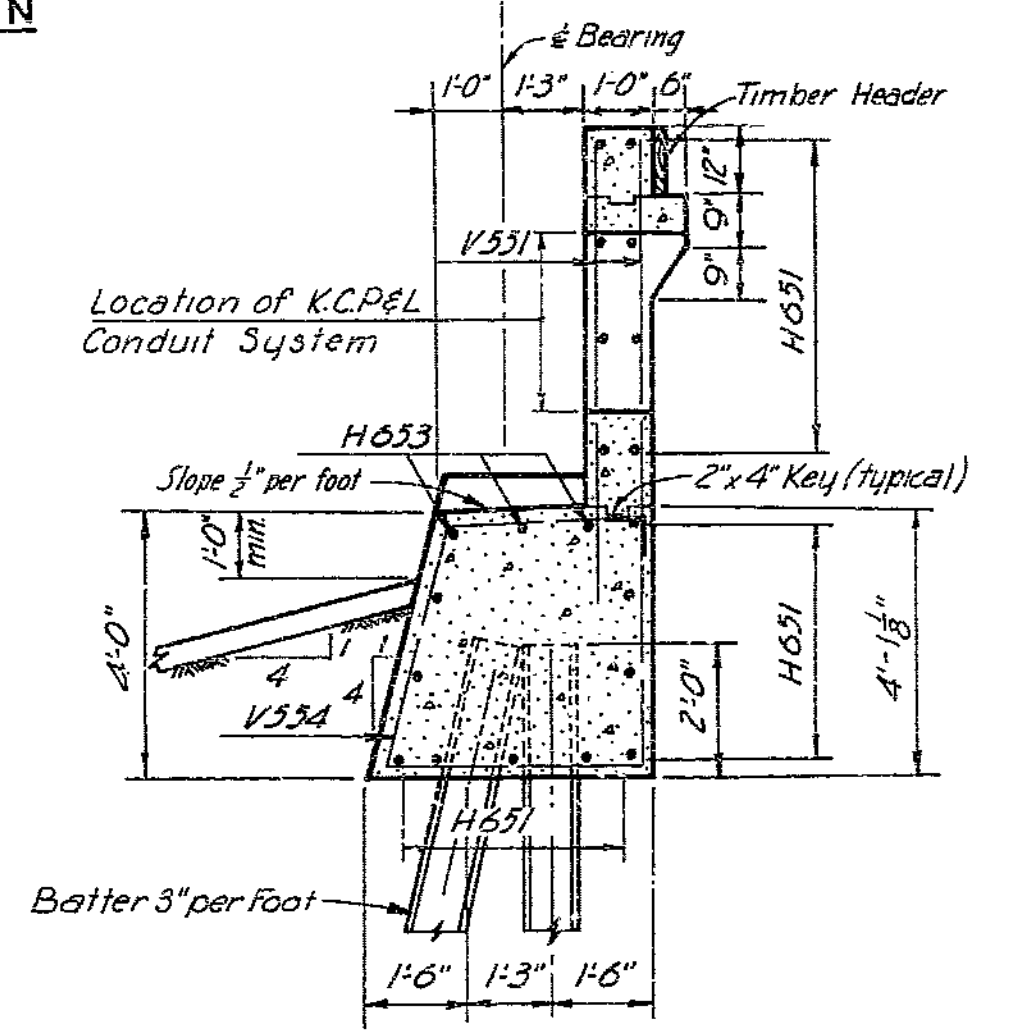

SECTION D-D

Notes:
 Piles shall be 10 BP42 battered 3" per foot where shown.
 Barrel and Maskwall Elevations are given at the Front Face of the Backwall.
 Dimensions and Elevations are given to the Face of Concrete.
 Concrete Cover on the Reinforcing Steel shall be 2" unless otherwise shown.
 For Wingwall details see sheet 8.
 For Pile splice, Shear key, and Rustication details see sheet 16.

Legend:
 n.f. = Near face
 f.f. = Far face
 e.f. = Each face

BRIDGE : CHARLOTTE STREET UNDERPASS
 CROSTOWN FREEWAY
 KANSAS CITY, MO.
 PROJECT NO. I-70-1 (41) (RT. I-70) STA. 47+99.11
 JACKSON COUNTY LANE A
 SHEET 7 OF 18 A-807

END BENT 9

NOTE: This drawing is not to scale. Follow dimensions.

HOWARD, NEEDLES, TAMMEN & BERGENOFF
 CONSULTING ENGINEERS
 KANSAS CITY NEW YORK
 MADE JAB/r DATE 11-5-60 TRACED DATE
 CHECKED JPS DATE 11-22-60 SCALE

255

MISSOURI STATE HIGHWAY DEPARTMENT

FED. ROAD DIV. NO.	STA 16	FEDERAL PROJECT NO. & SEC.	FISCAL YEAR	SHEET NO.	TOTAL SHEETS
5	MO.			44	
DIST. NO.	4	COUNTY	ROUTE	SEC.	

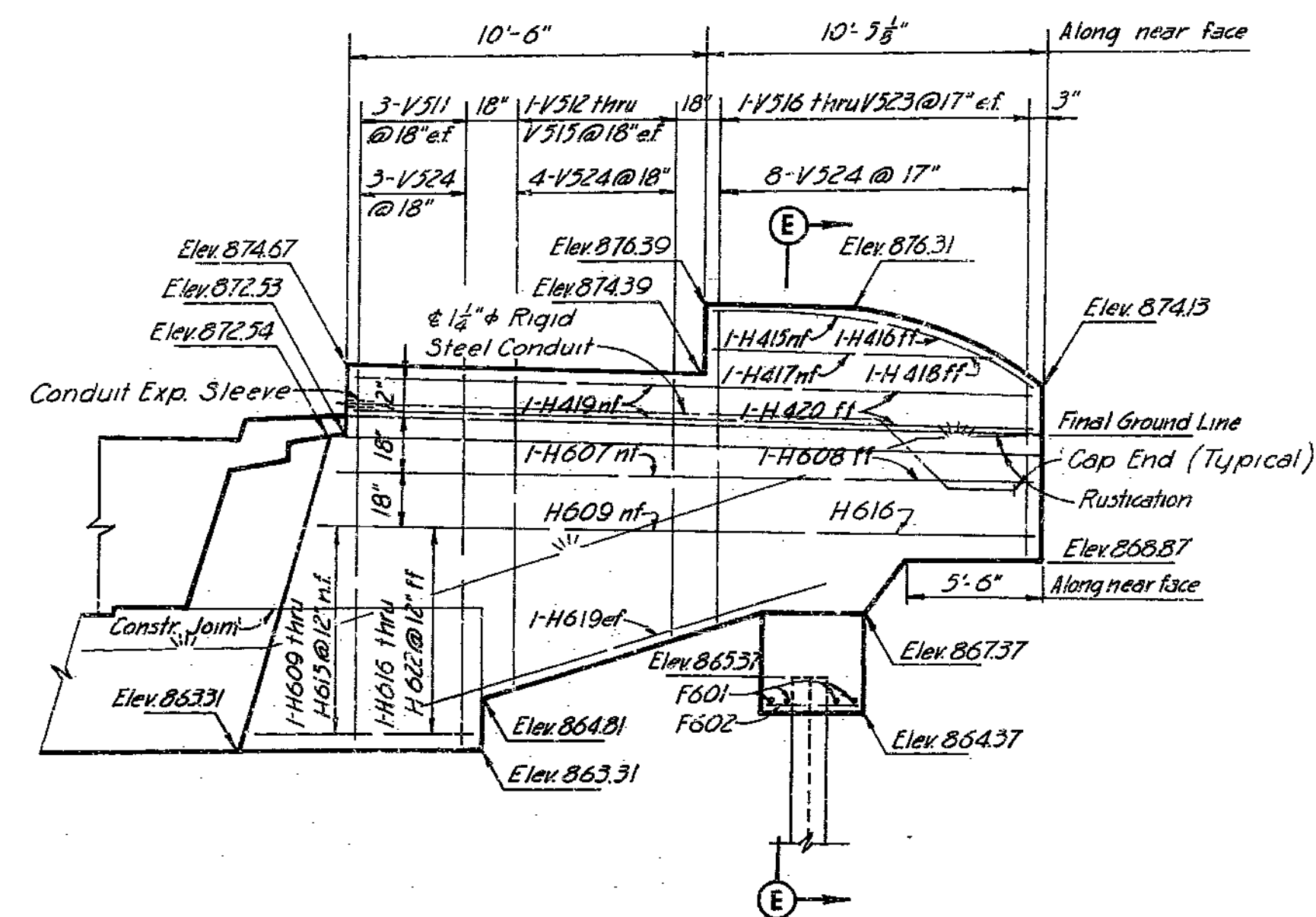

END BENT 1 EAST WINGWALL ELEVATION

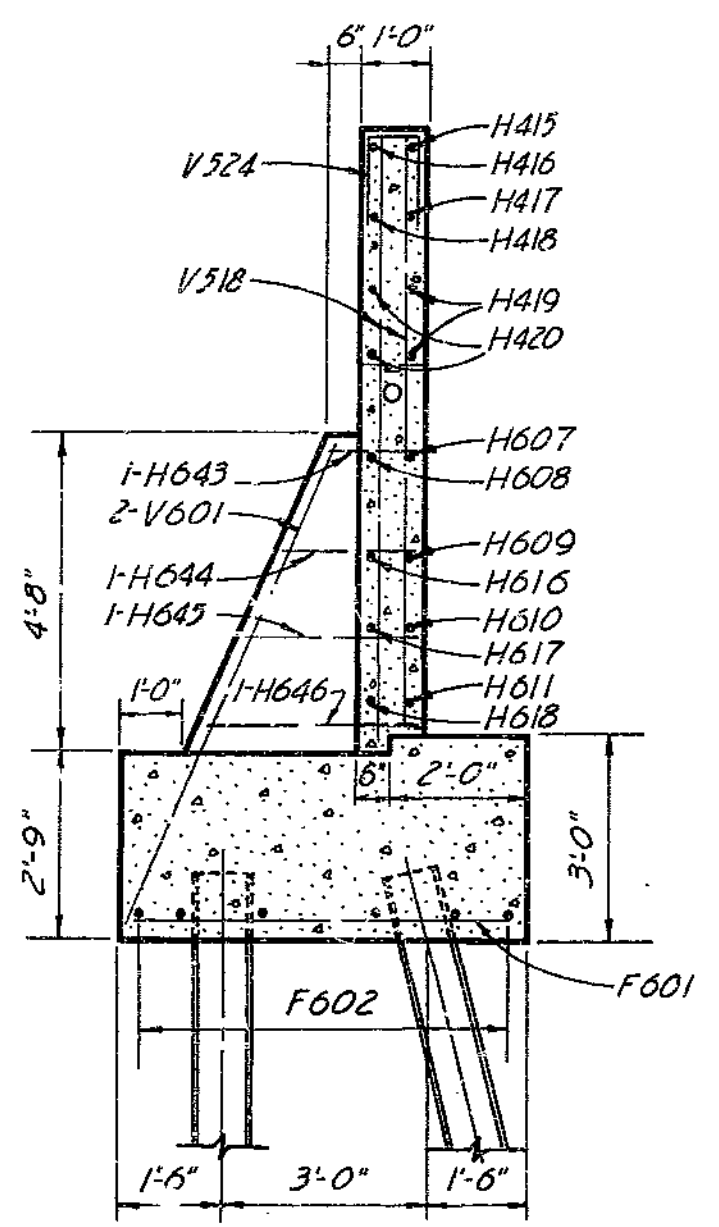

SECTION E-E

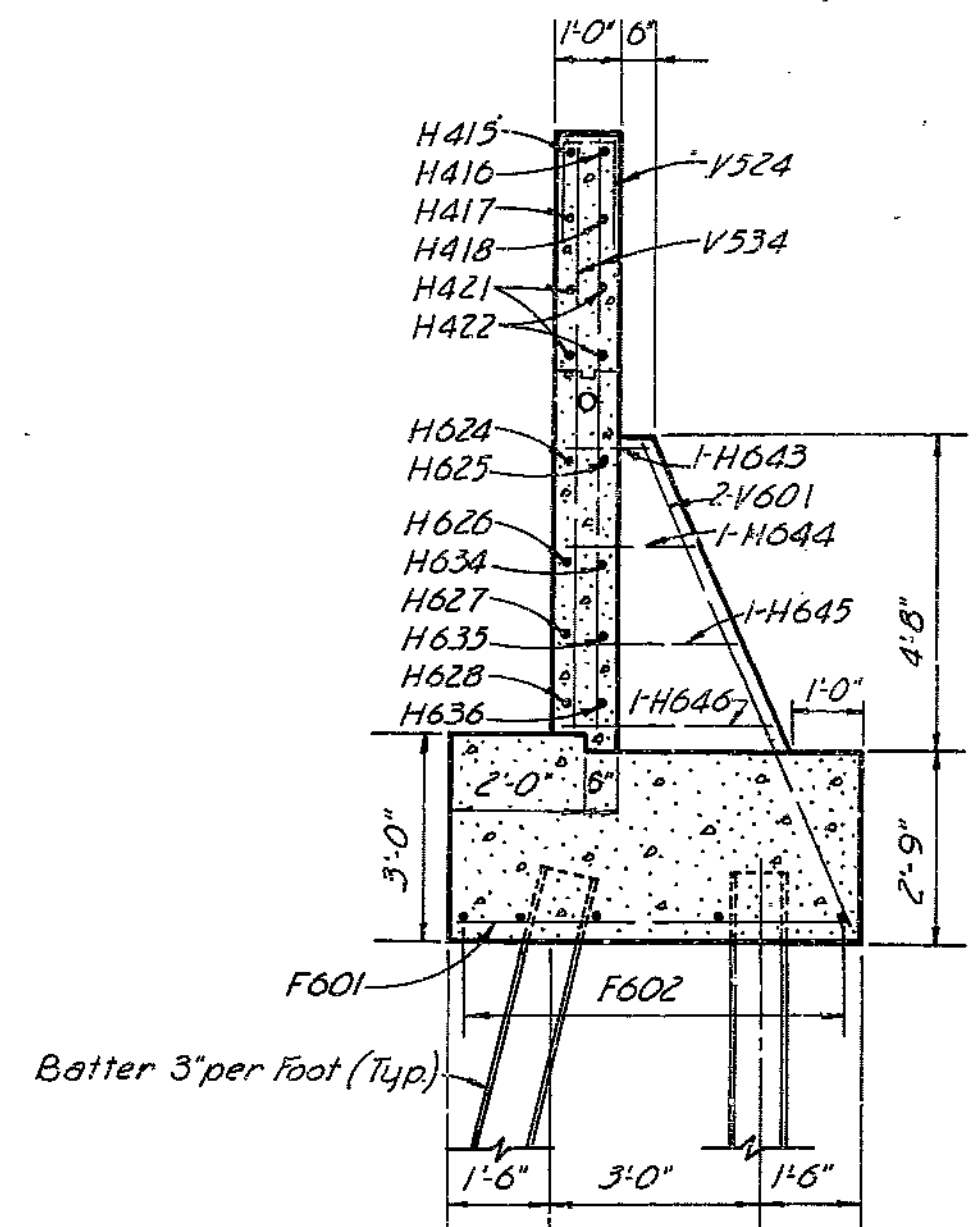

SECTION F-F

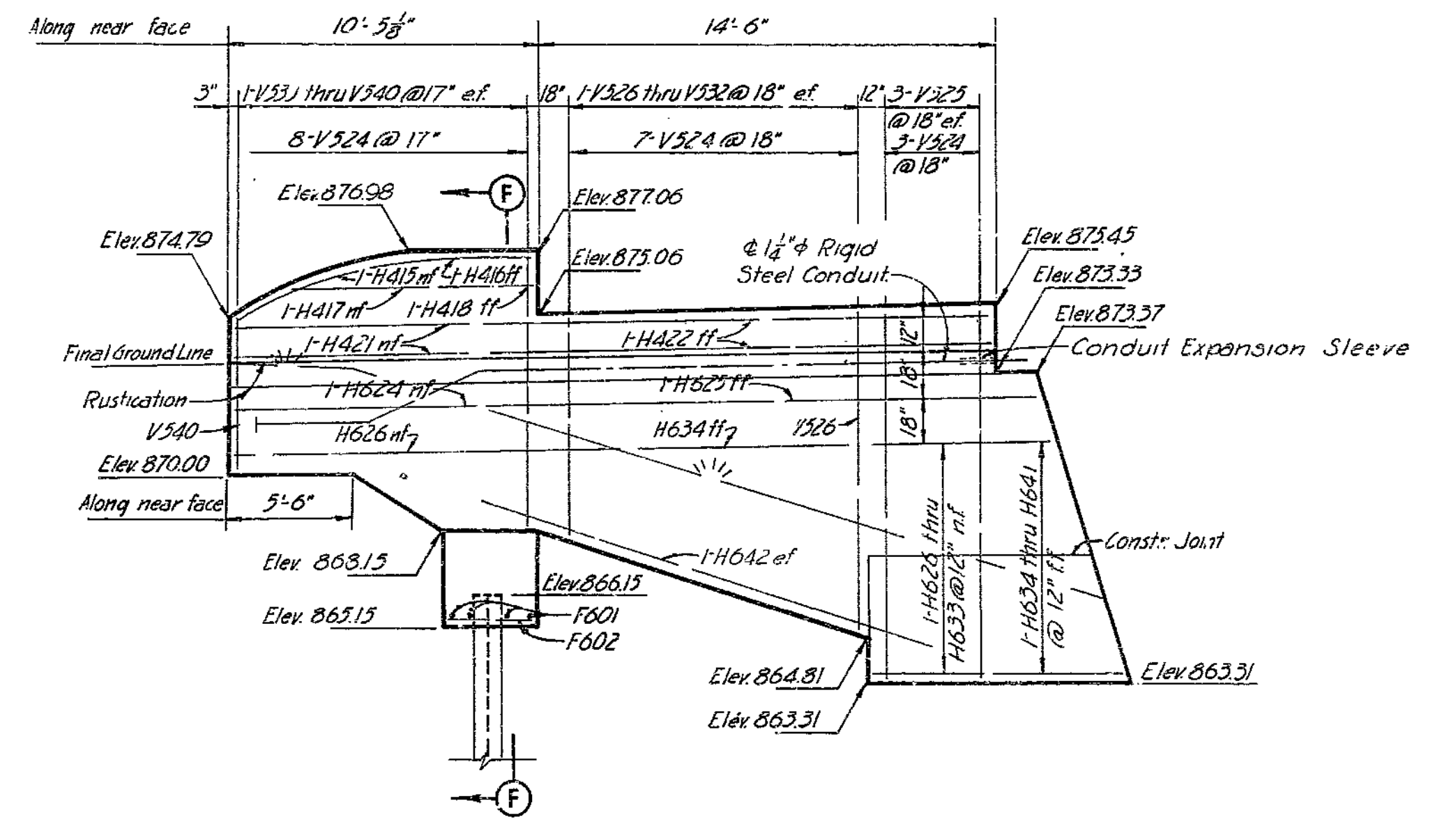

END BENT 1 WEST WINGWALL ELEVATION

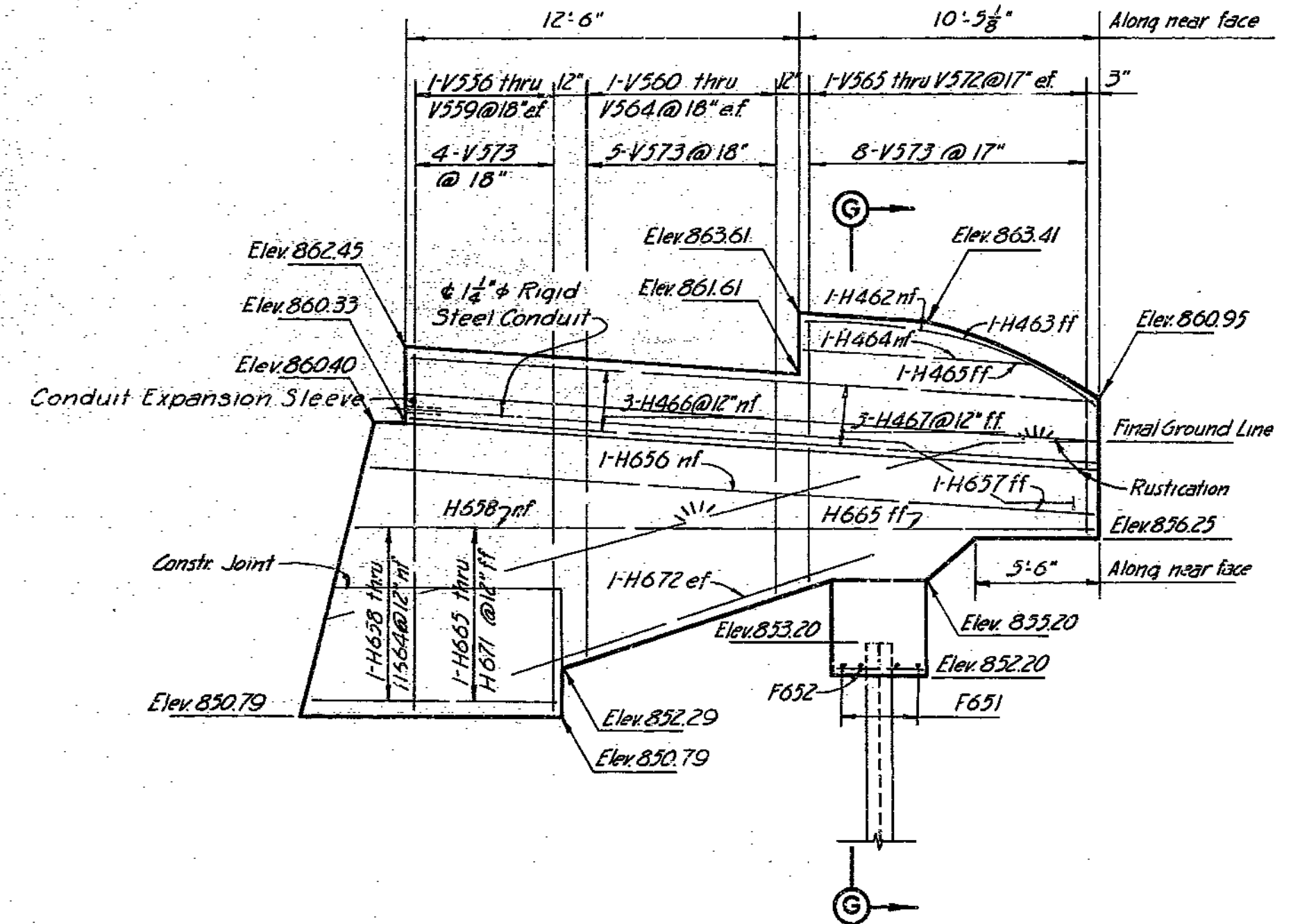

END BENT 9 WEST WINGWALL ELEVATION

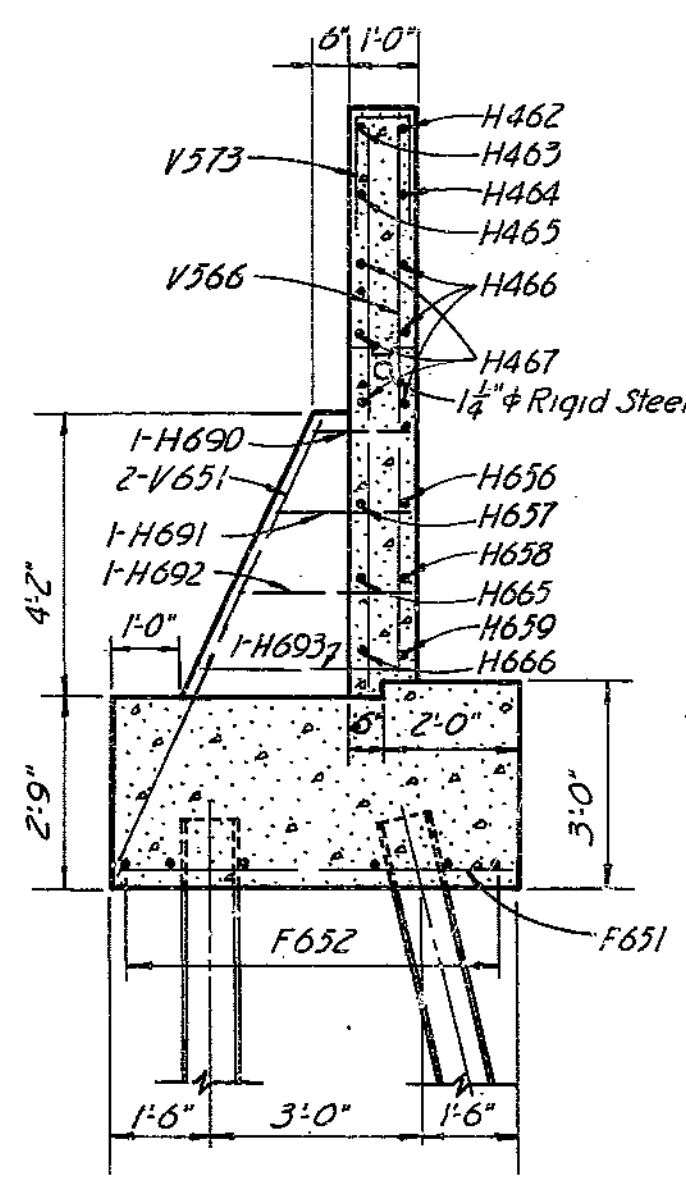

SECTION G-G

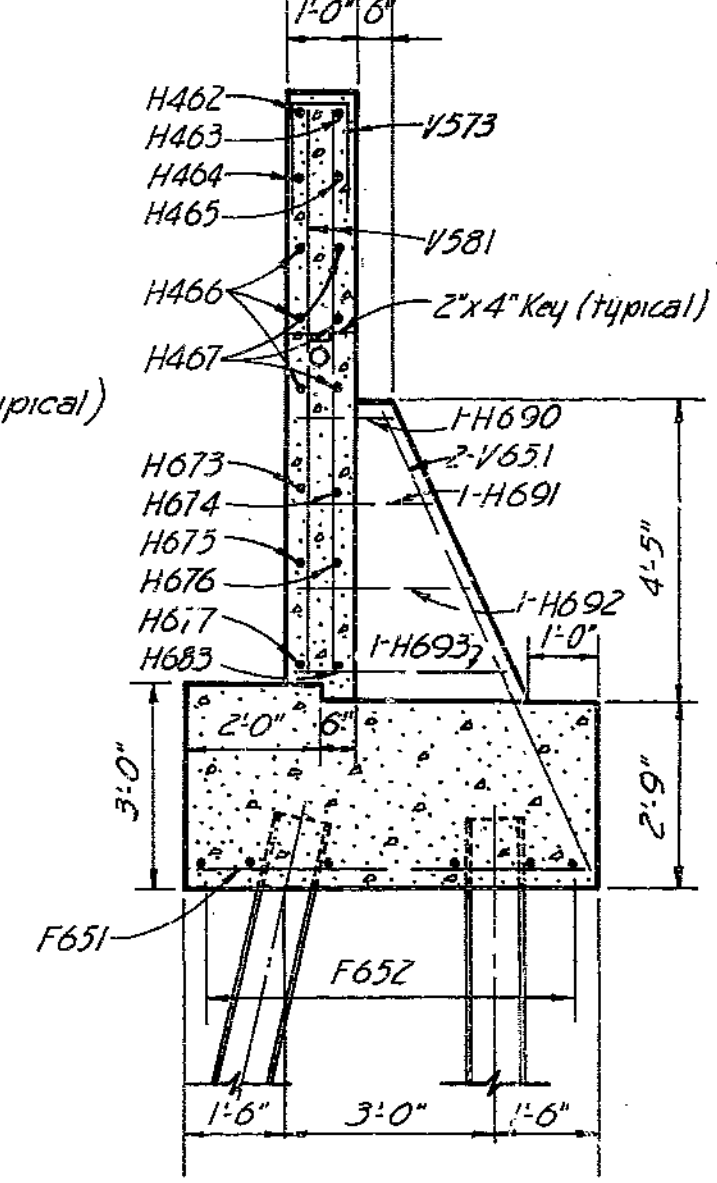

SECTION H-H

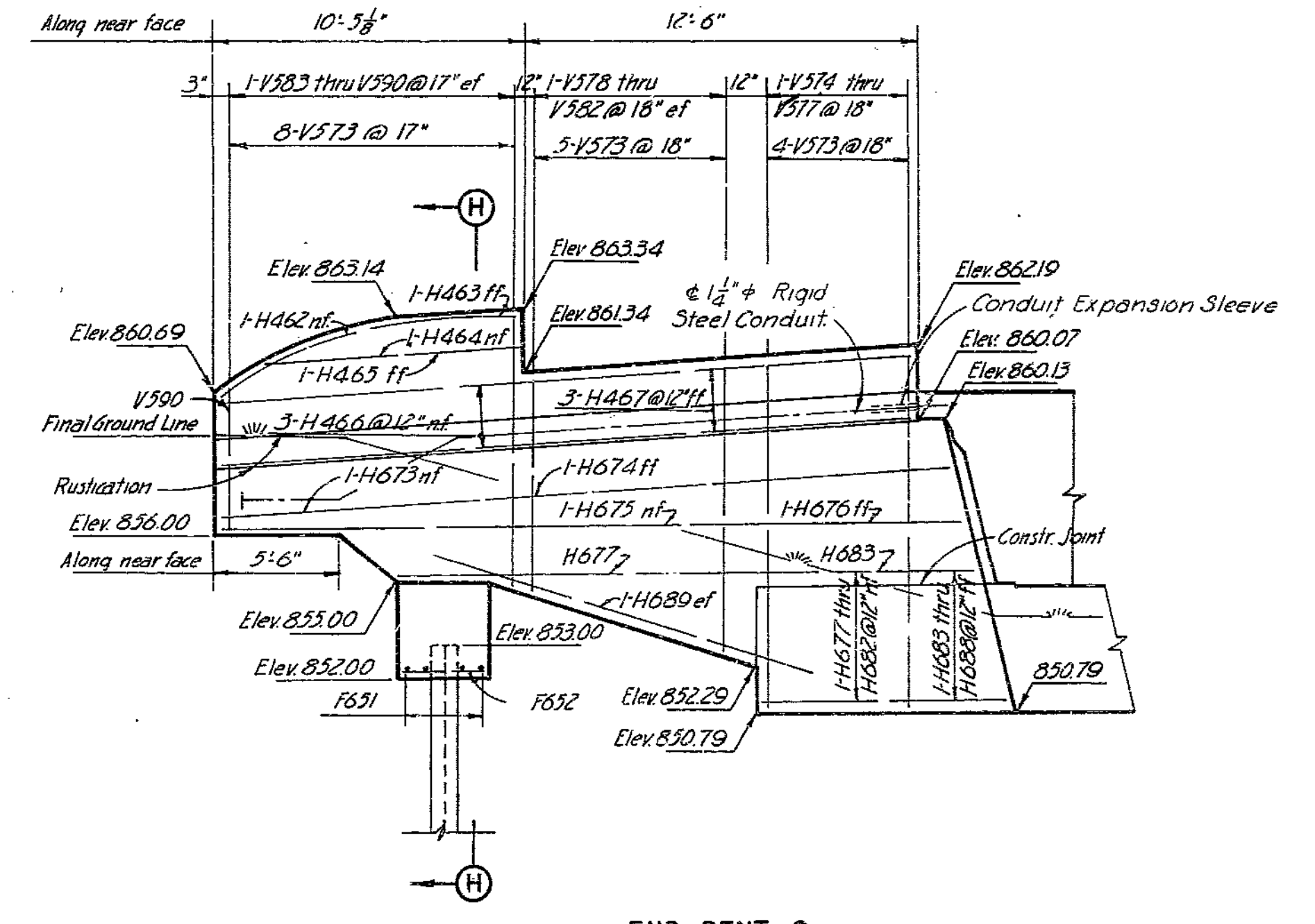

END BENT 9 EAST WINGWALL ELEVATION

Legend:
 nf = Near face
 ff = Far face
 ef = Each face

END BENT DETAILS

BRIDGE : CHARLOTTE STREET UNDERPASS
 CROSSTOWN FREEWAY
 KANSAS CITY, MO.
 PROJECT NO. 1-70-1 (41) (RT. 1-70) STA. 47+99.11
 JACKSON COUNTY @ LANE A
 SHEET 8 OF 18 A-807

HOWARD, NEEDLES, TAMMEN & BERGENDOFF
 CONSULTING ENGINEERS
 KANSAS CITY NEW YORK

MADE JAB/ll DATE 10-31-60 TRACED DATE
 CHECKED JPS DATE 11-22-60 SCALE

NOTE: This drawing is not to scale. Follow dimensions.

256

MISSOURI STATE HIGHWAY DEPARTMENT

5	MO.	45
4	COUNTY	ROUTE SEC.

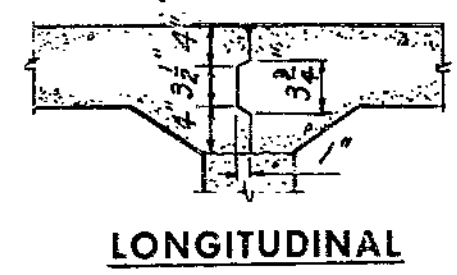
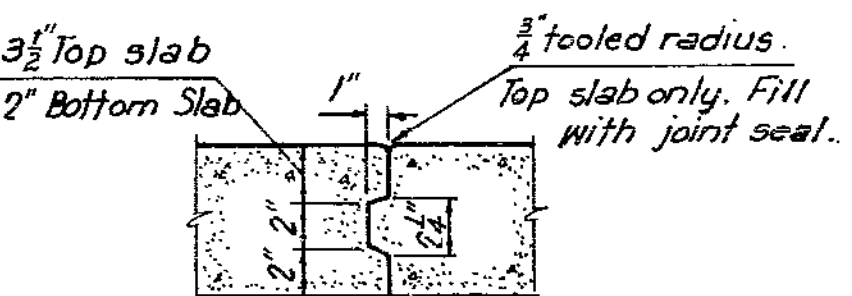
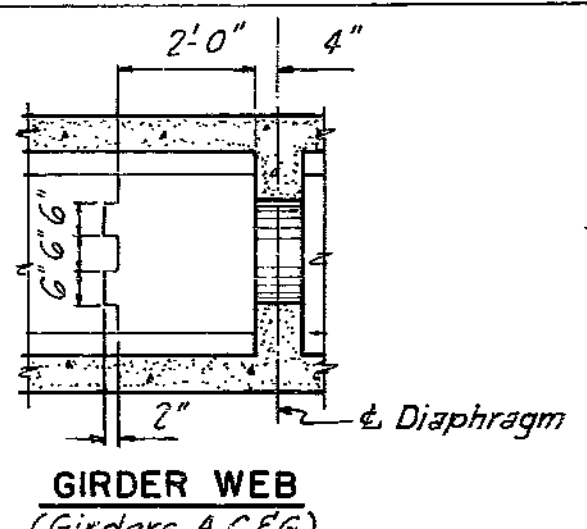
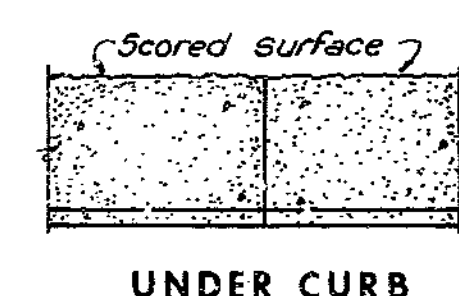
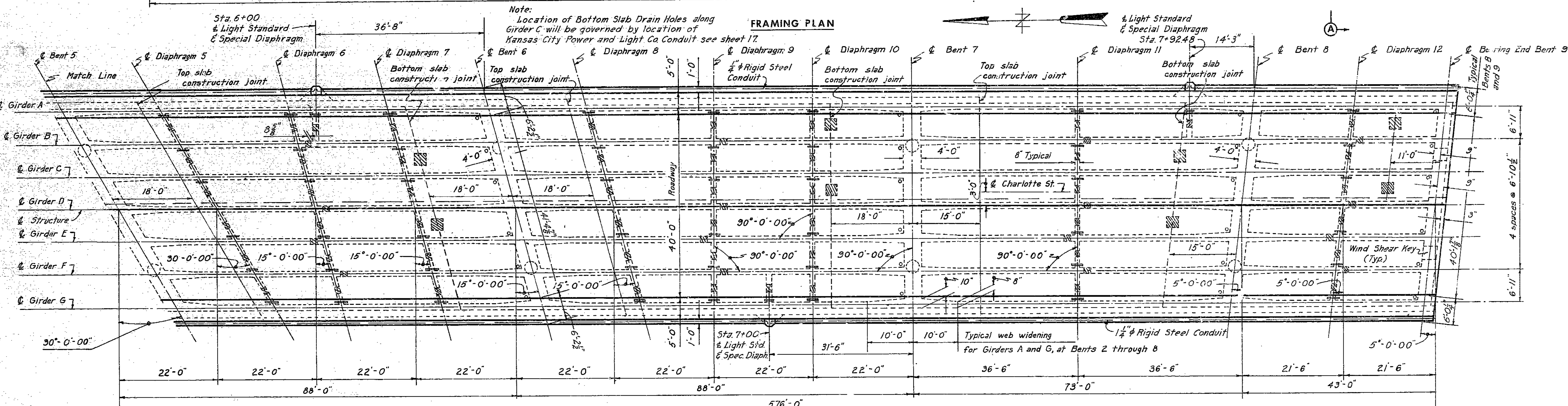
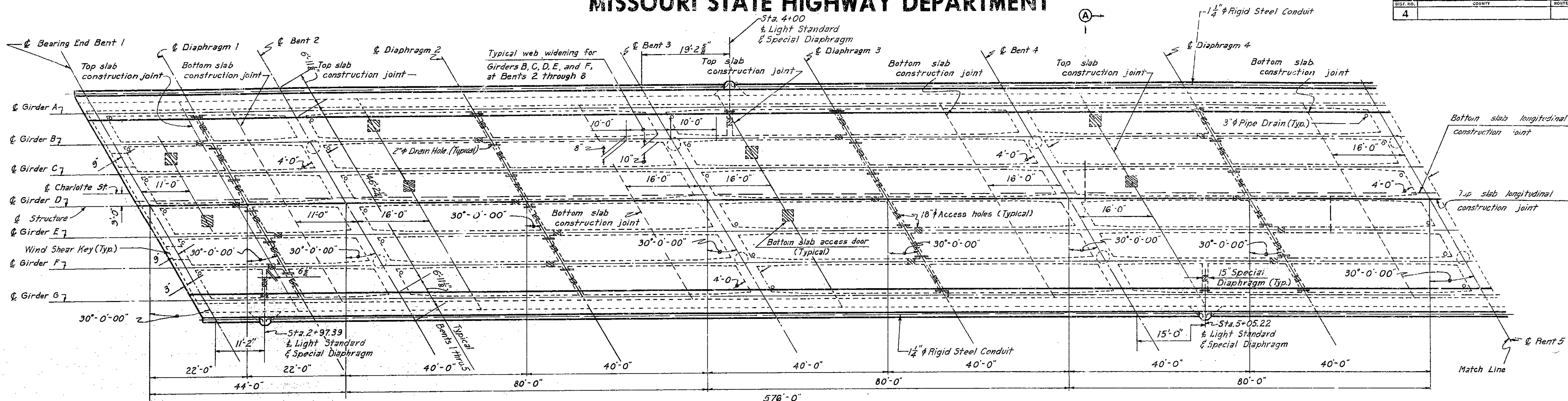

Note:
For Section A-A see Sheet 14.
For diaphragm details see Sheet 13.
For special diaphragm and Access Hole details see Sheet 14.

NOTE: This drawing is not to scale. Follow dimensions.

CONSTRUCTION JOINTS

FRAMING PLAN

HOWARD, NEEDLES, TAMMEN & BERGENDOFF
CONSULTING ENGINEERS
KANSAS CITY NEW YORK
MADE RVS DATE 6-27-60 TRACED DATE
CHECKED J.L.W. DATE 11-18-60 SCALE

BRIDGE: CHARLOTTE STREET UNDERPASS
CROSSTOWN FREEWAY
KANSAS CITY, MO.
PROJECT NO. I-70-1 (41) (RT. I-70) STA. 47+99.11 & LANE A
JACKSON COUNTY
SHEET 9 OF 18
A-807

MISSOURI STATE HIGHWAY DEPARTMENT

FED. ROAD DIST. NO.	STATE	FEDERAL PROJECT NO. & SEC.	FISCAL YEAR	SHEET NO.	TOTAL SHEETS
5	MO.			46	
DIST. NO.	COUNTY	ROUTE	SEC.		
4					

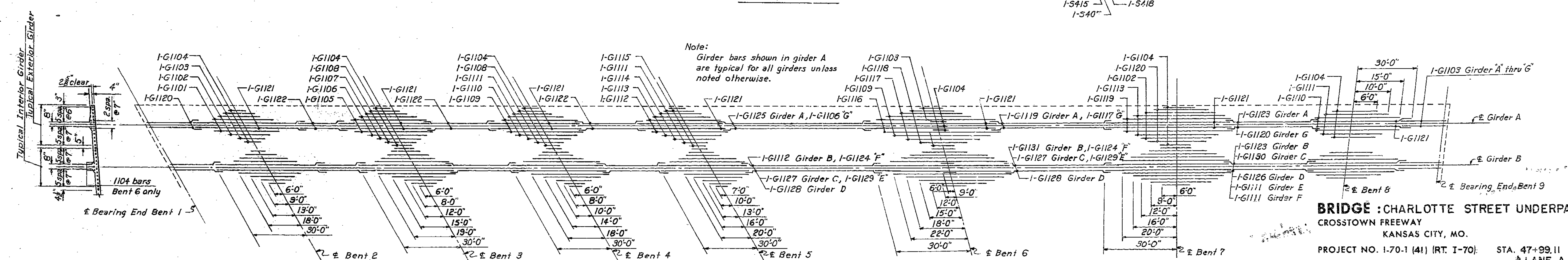
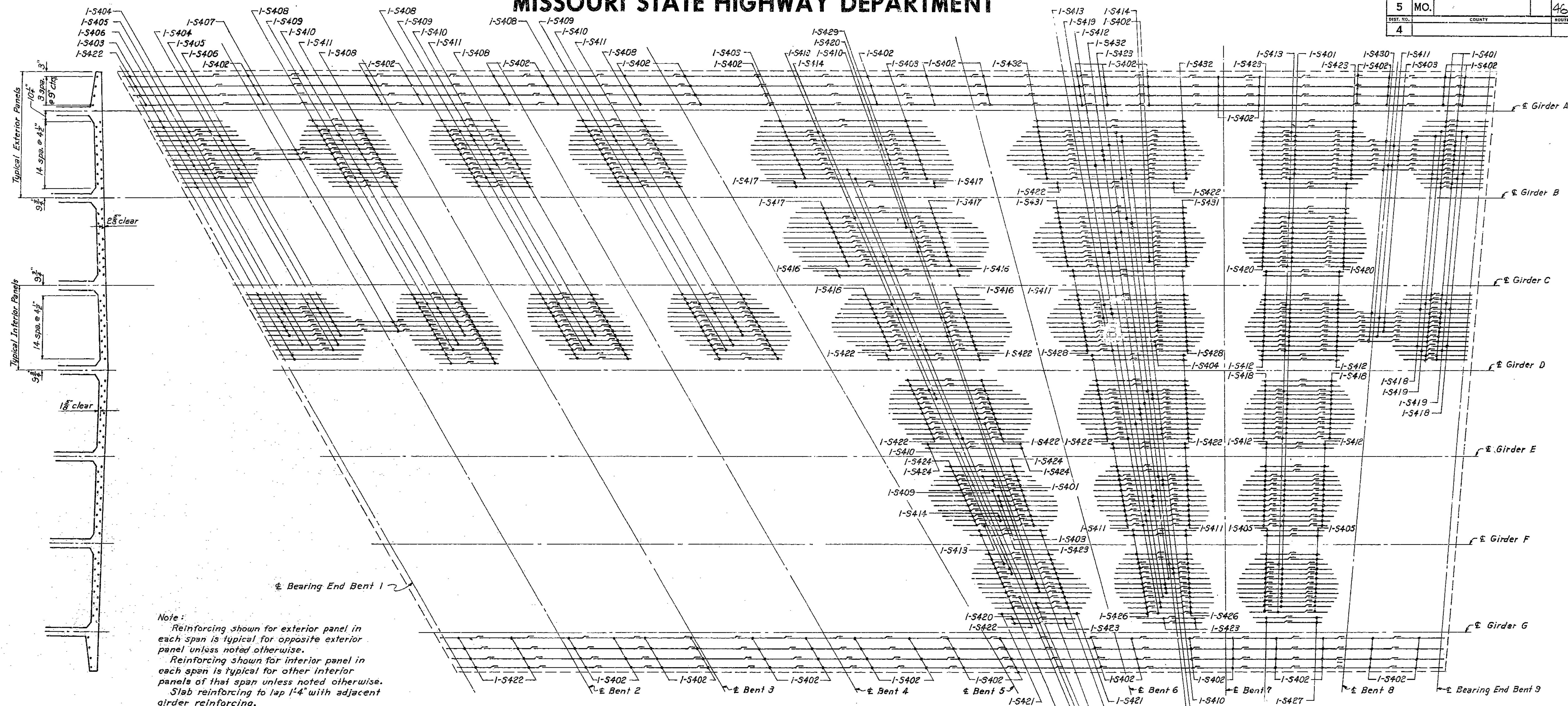

258

HOWARD, NEEDLES, TAMMEN & BERGENDOFF
 CONSULTING ENGINEERS
 KANSAS CITY, MISSOURI
 NEW YORK

MADE RGP DATE 7-1-60 TRACED DATE
 CHECKED JLW DATE 11-23-60 SCALE

NOTE: This drawing is not to scale. Follow dimensions.

GIRDER REINFORCING

TOP SLAB LONGITUDINAL REINFORCING

BRIDGE: CHARLOTTE STREET UNDERPASS
 CROSSTOWN FREEWAY
 KANSAS CITY, MO.
 PROJECT NO. 1-70-1 (41) (RT. I-70) STA. 47+99.11
 LANE A

JACKSON COUNTY

SHEET 10 OF 18

A-807

MISSOURI STATE HIGHWAY DEPARTMENT

FED. ROAD DIST. NO.	STATE	FEDERAL PROJECT NO. & SEC.	FISCAL YEAR	SHEET NO.	TOTAL SHEETS
5	MO.			47	
DIST. NO.	COUNTY	ROUTE	SEC.		
4					

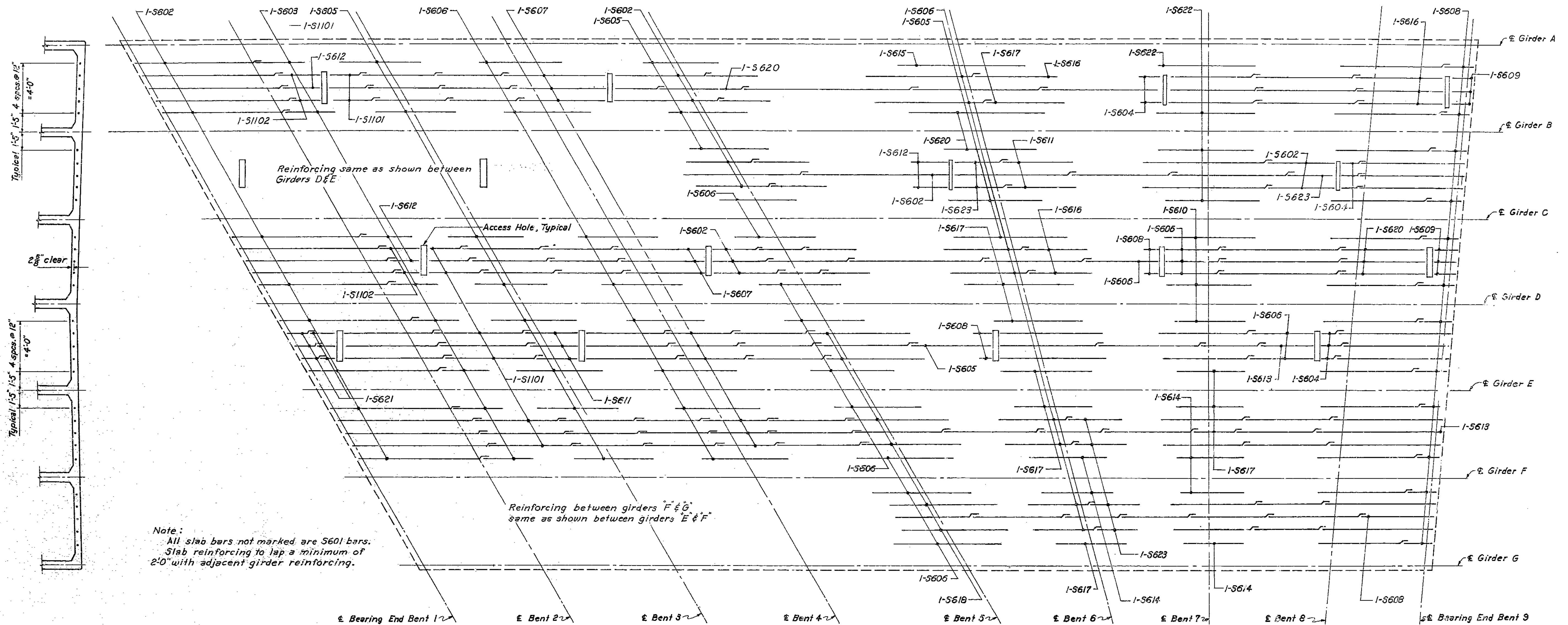

SLAB REINFORCING

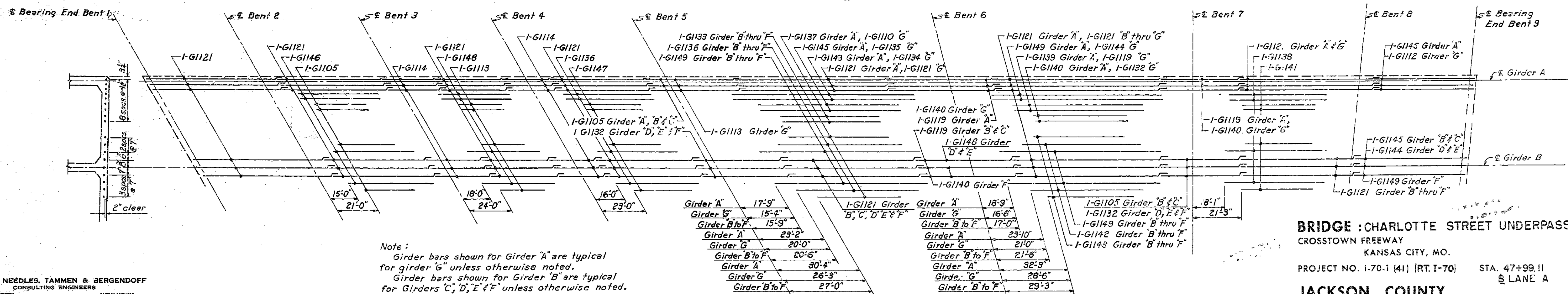

GIRDER REINFORCING

BOTTOM SLAB LONGITUDINAL REINFORCING

BRIDGE: CHARLOTTE STREET UNDERPASS
 CROSSTOWN FREEWAY
 KANSAS CITY, MO.
 PROJECT NO. 1-70-1 (41) (RT. I-70) STA. 47+99.11
 JACKSON COUNTY
 LANE A

HOWARD, NEEDLES, TAMMEN & BERGENDOFF
 CONSULTING ENGINEERS
 KANSAS CITY NEW YORK

MADE RGP DATE 9-9-60 TRACED DATE
 CHECKED J.L.W. DATE 11-23-60 SCALE

NOTE: This drawing is not to scale. Follow dimensions.

259

MISSOURI STATE HIGHWAY DEPARTMENT

FED. ROAD DIST. NO.	STATE	FEDERAL PROJECT NO. & SEC.	FISCAL YEAR	SHEET NO.	TOTAL SHEETS
5	MO.			48	
DIST. NO.	COUNTY			NO.	
4					

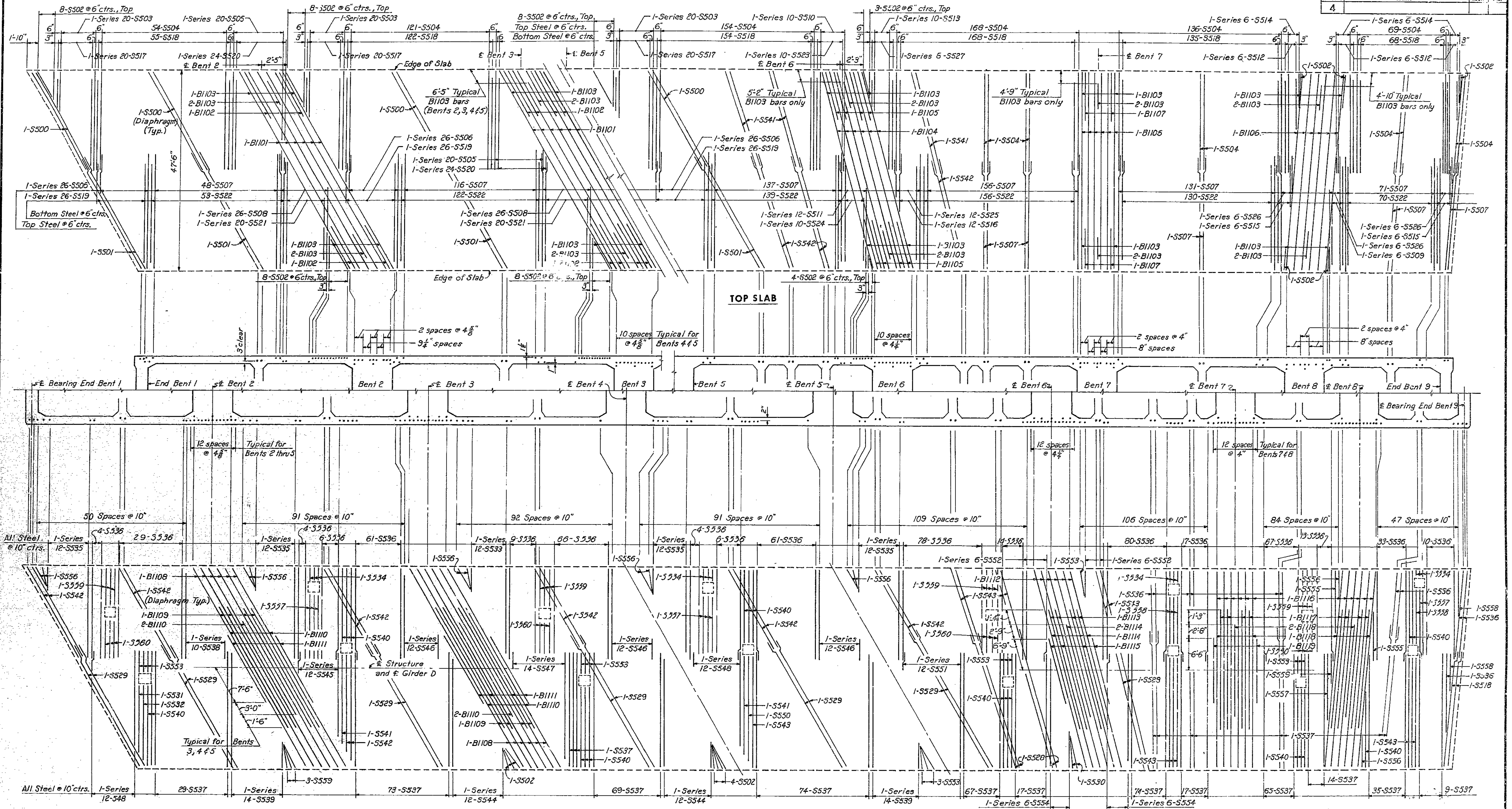

TOP SLAB

TRANSVERSE REINFORCING

Note: For section thru Cap Beam see sheet 14
 Top slab reinforcing shown from Bent 2 to Bent 3 typical for spans from Bent 3 to Bent 3.
 Cap Beam steel shown for Bent 3 typical for Bents 4 and 5.

BRIDGE : CHARLOTTE STREET UNDERPASS
 CROSSTOWN FREEWAY
 KANSAS CITY, MO.
 PROJECT NO. 1-70-1 (41) (RT. 1-70) STA 47+98.11
 JACKSON COUNTY
 LANE A

TRANSVERSE REINFORCING

HOWARD, NEEDLES, TAMMEN & BERGENDOFF *
 CONSULTING ENGINEERS
 KANSAS CITY NEW YORK

MADE	RGP	DATE	3-26-60	TRACED		DATE	
CHECKED	JLW	DATE	11-23-60	SCALE			

NOTE: This drawing is not to scale. Follow dimensions.

2607

MISSOURI STATE HIGHWAY DEPARTMENT

FED. ROAD DIST. NO.	STATE	FEDERAL PROJECT NO. & SEC.	YEAR	SHEET NO.	TOTAL SHEETS
5	MO.			49	
POST. NO.	COUNTY	ROUTE	SEC.		
4					

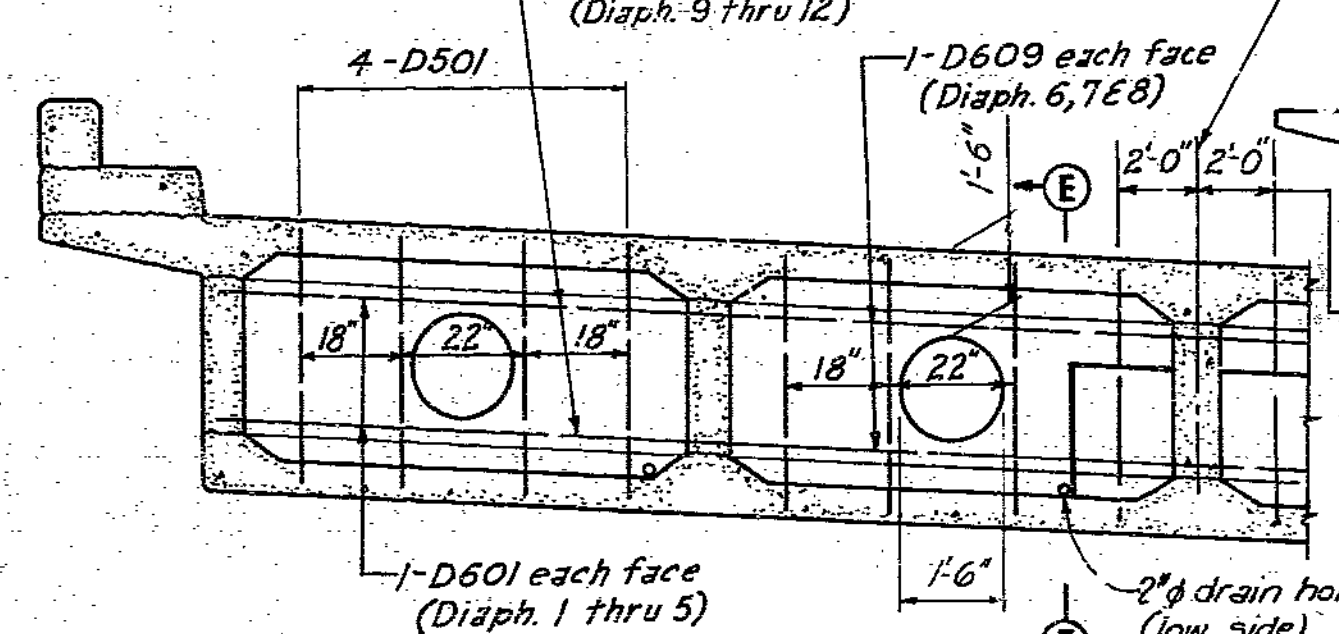
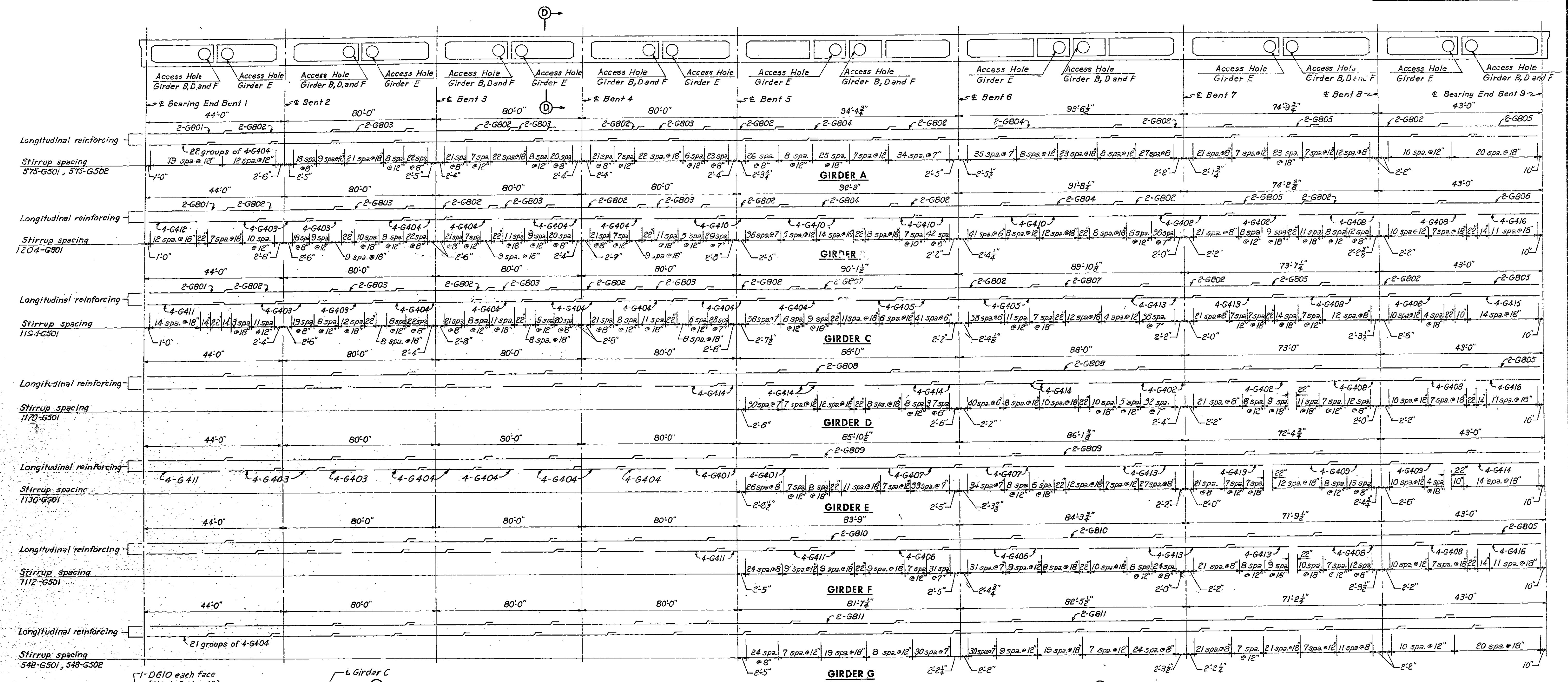

Note: For details of Special Diaphragm see sheet 14.

DIAPHRAGM DETAILS

Note: For location and details of Conduit System for K.C. Power and Light Co. see sheet 17.

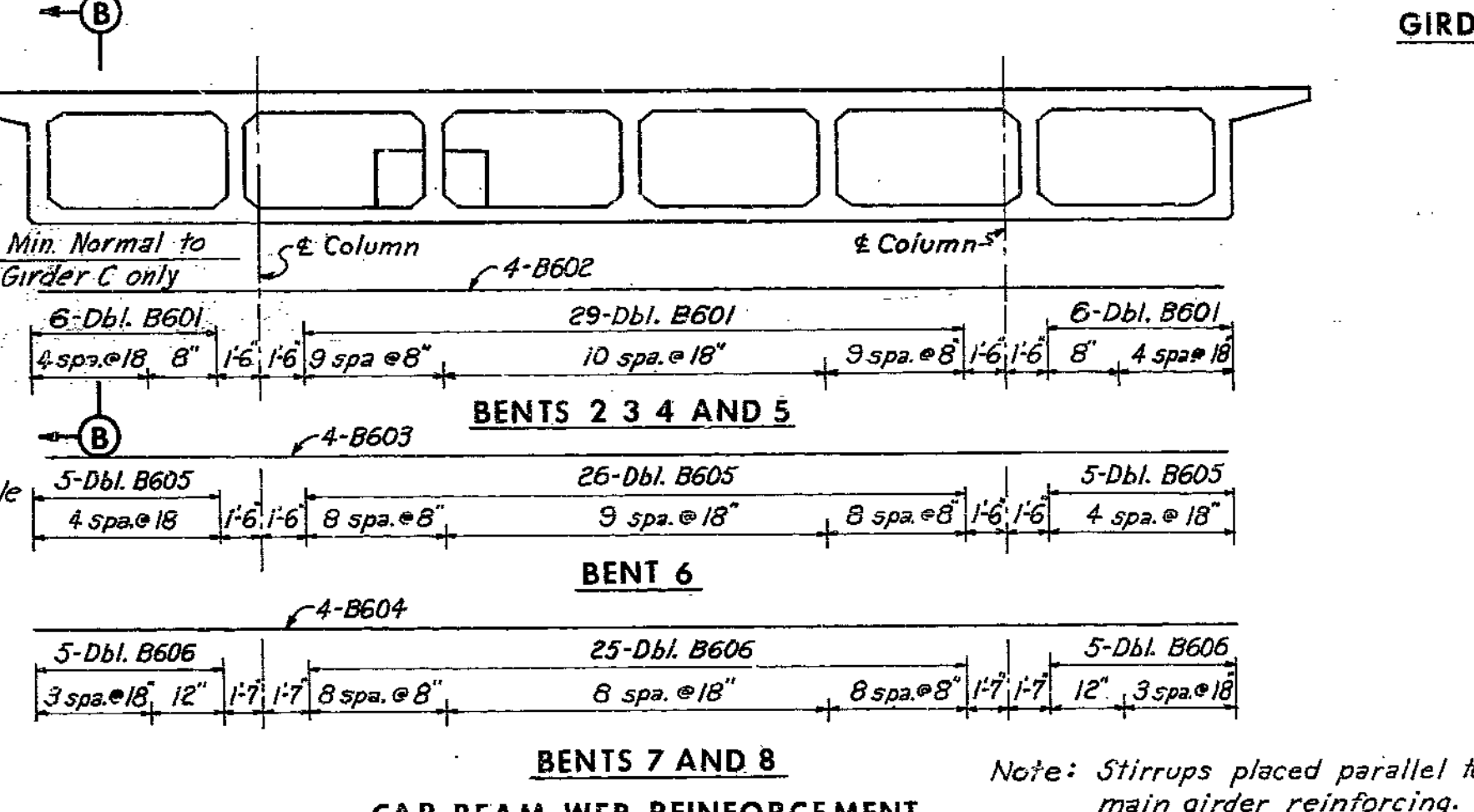

BENTS 2 3 4 AND 5

BENT 6

BENTS 7 AND 8

CAP BEAM WEB REINFORCEMENT

Note: Stirrups placed parallel to main girder reinforcing.

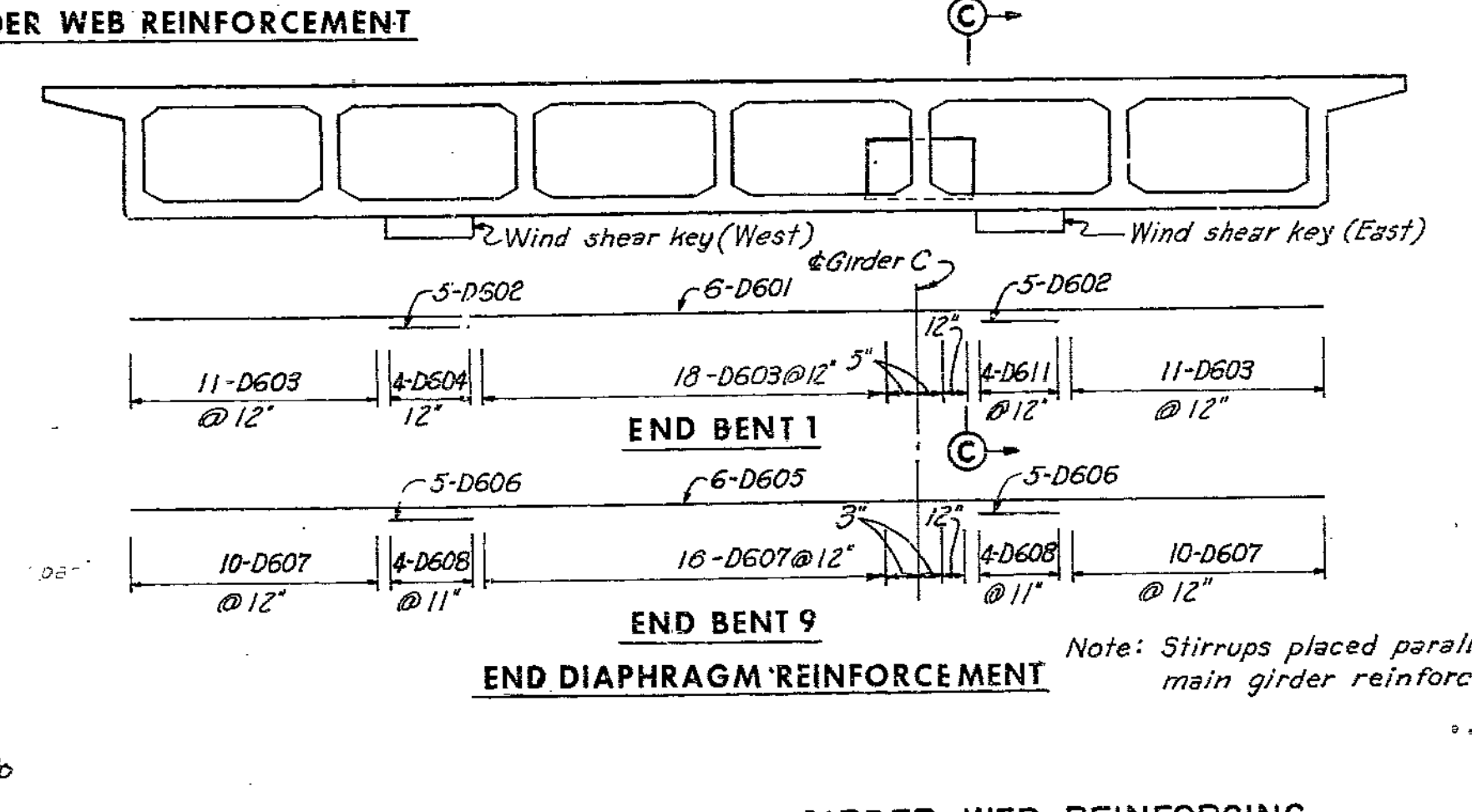

GIRDER WEB REINFORCING

Note: Stirrups placed parallel to main girder reinforcing.

Note: Reinforcement for girders D and F similar to girder B except as shown.
 Reinforcement for girder E similar to girder C except as shown.
 Reinforcement for girder G similar to girder A except as shown.
 For Sections B-B, C-C, D-D and E-E see Sheet 14.

BRIDGE : CHARLOTTE STREET UNDERPASS
 CROSSTOWN FREEWAY
 KANSAS CITY, MO.
 PROJECT NO. 1-70-1 (41) (RT. I-70) STA. 47+99.11
 LANE A

JACKSON COUNTY
 SHEET 13 OF 18
 A-807

HOWARD, NEEDLES, TAMMEN & BERGENDOFF
 CONSULTING ENGINEERS
 KANSAS CITY NEW YORK

MADE RGP DATE 10-5-60 TRACED DATE
 CHECKED ABX DATE 11-21-60 SCALE

NOTE: This drawing is not to scale. Follow dimensions.

Bent	Dim. A'	Dim. B'
2	1 1/2"	
3	1 1/2"	
4	0"	0"
5		1 1/2"
6		2 1/2"
7		3 1/2"
8		3 1/2"

5	MO.	50
4		

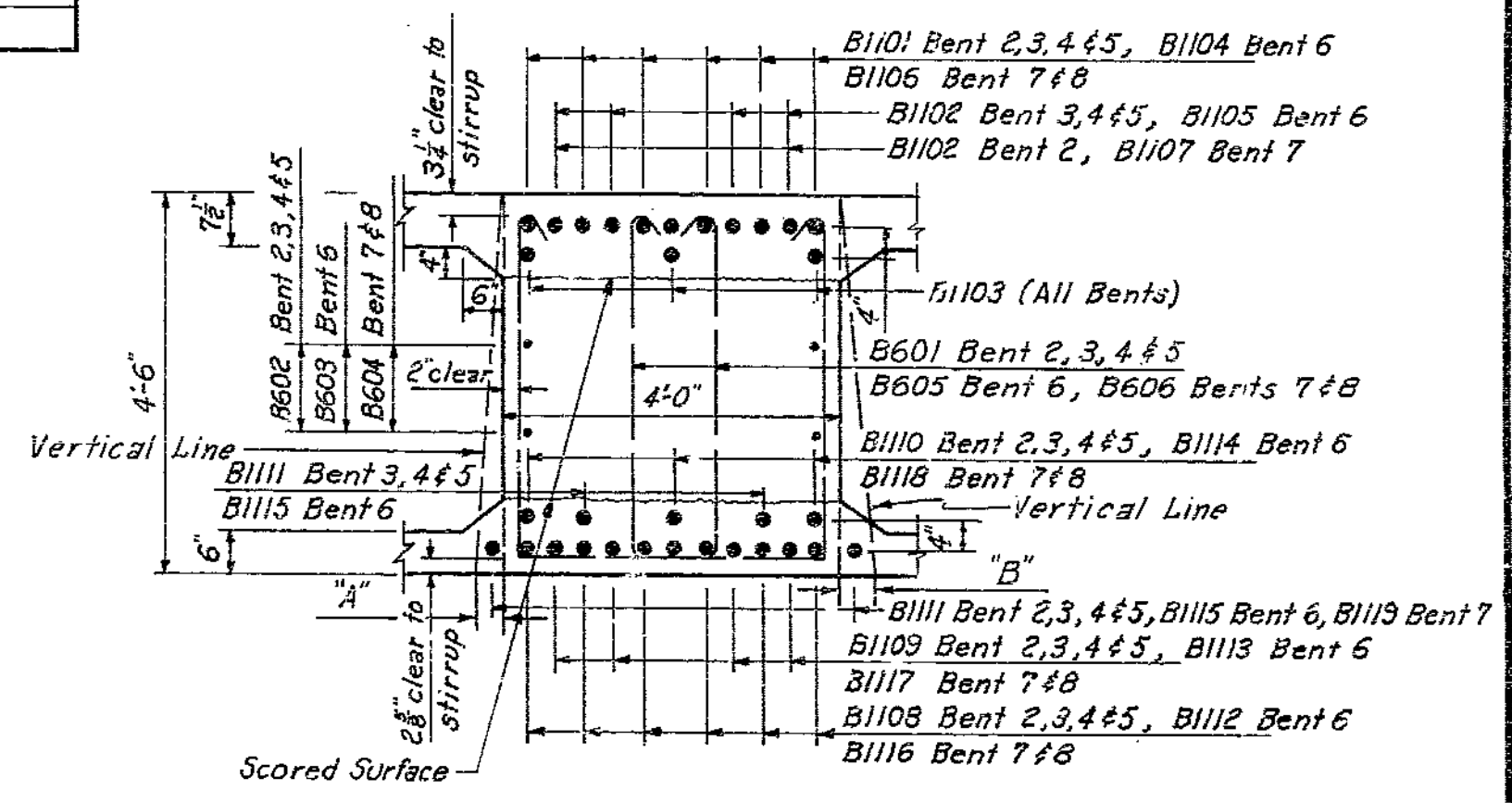
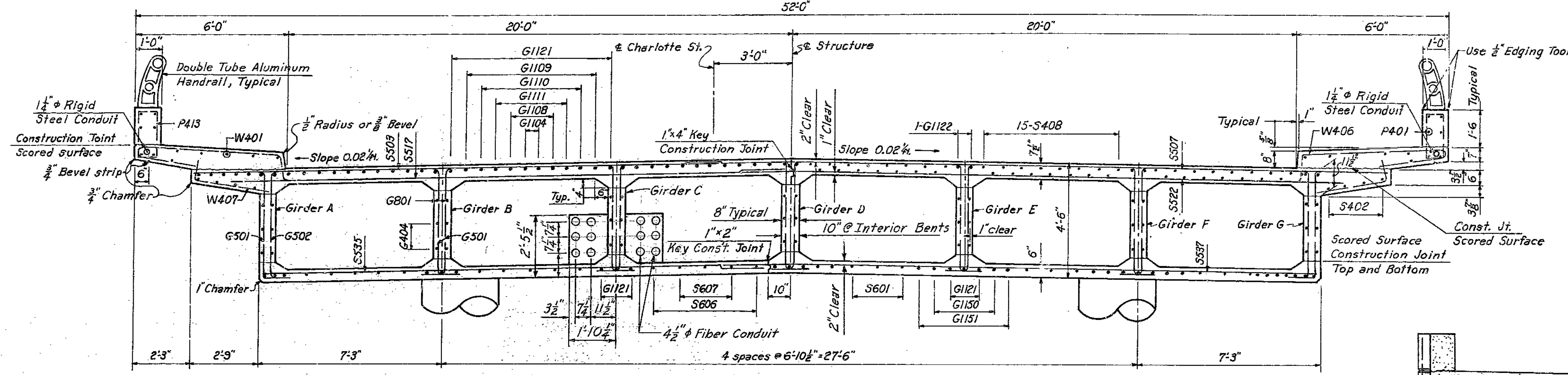
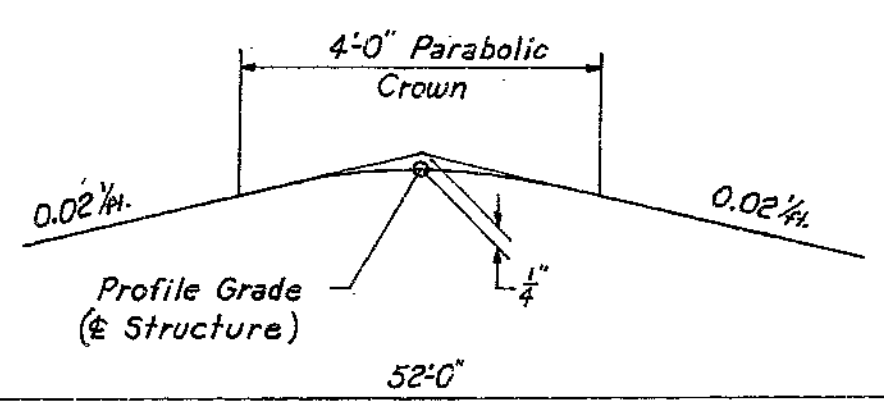

Note:
For details of Conduit System
for Kansas City Power and Light
Co. see sheet 17.

SECTION A-A

SECTION B-B

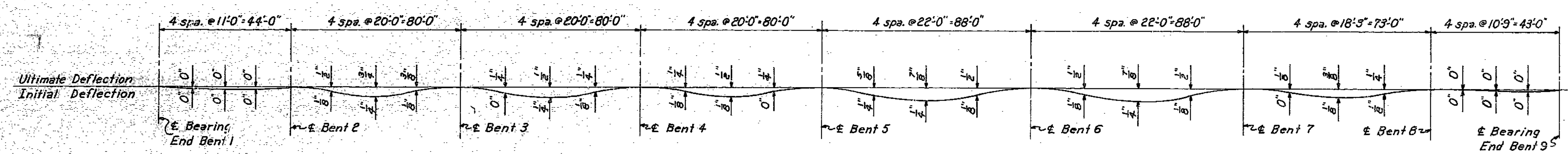

DEAD LOAD DEFLECTION DIAGRAM

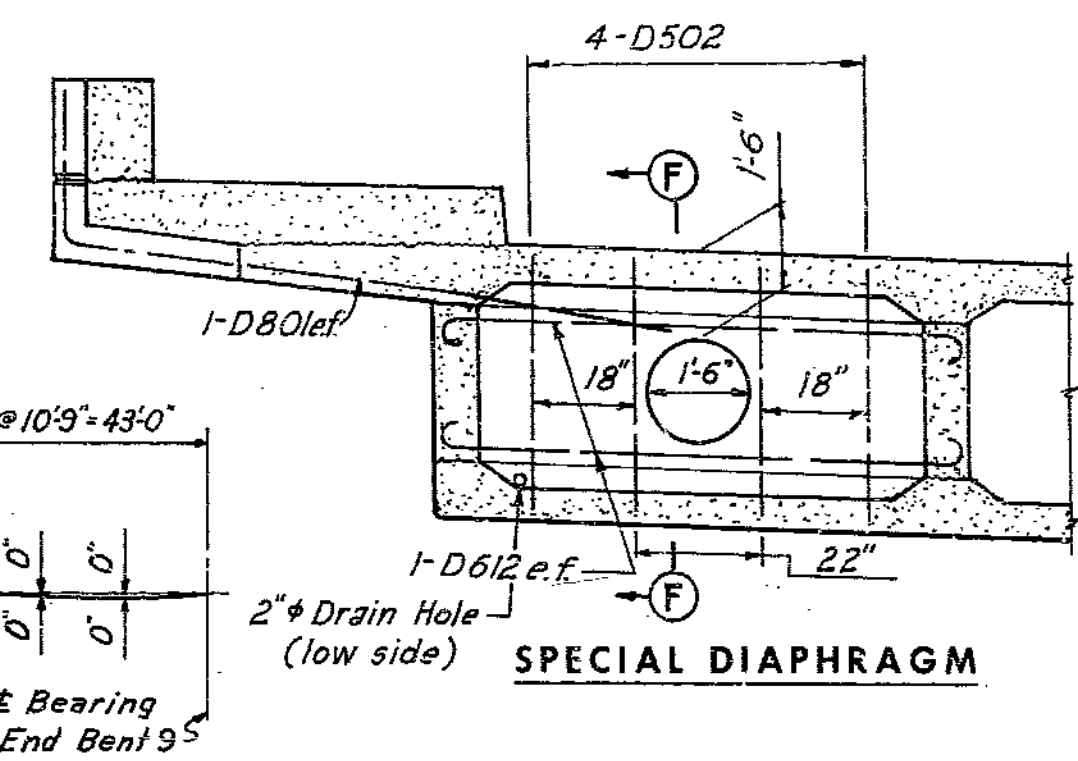

SPECIAL DIAPHRAGM

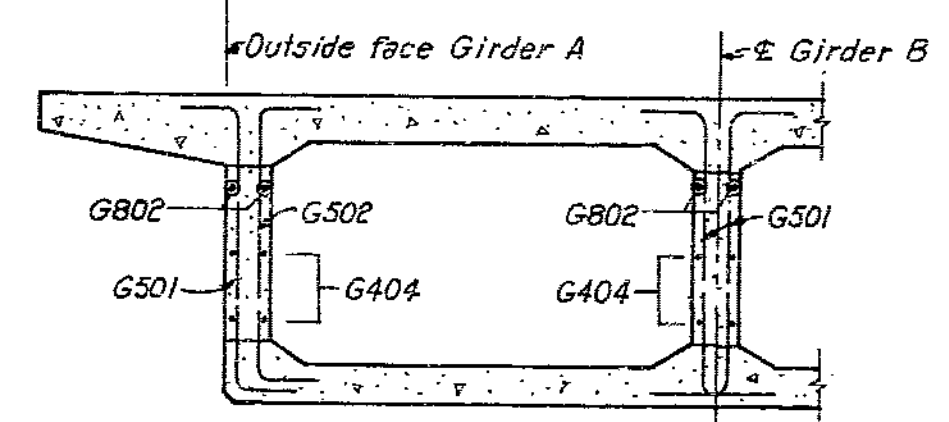

SECTION D-D

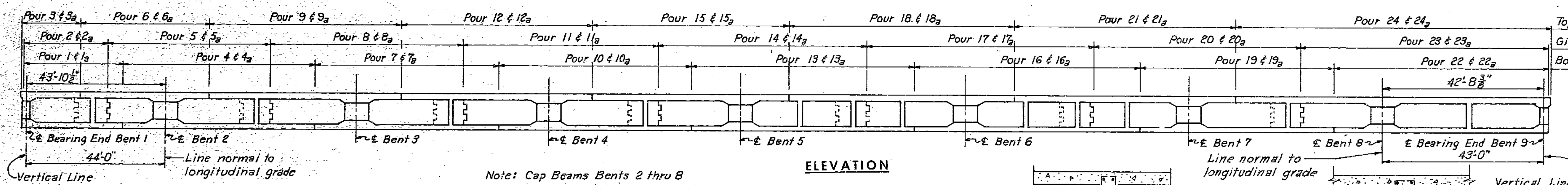

ELEVATION

Note: Cap Beams Bents 2 thru 8
are normal to longitudinal grade.

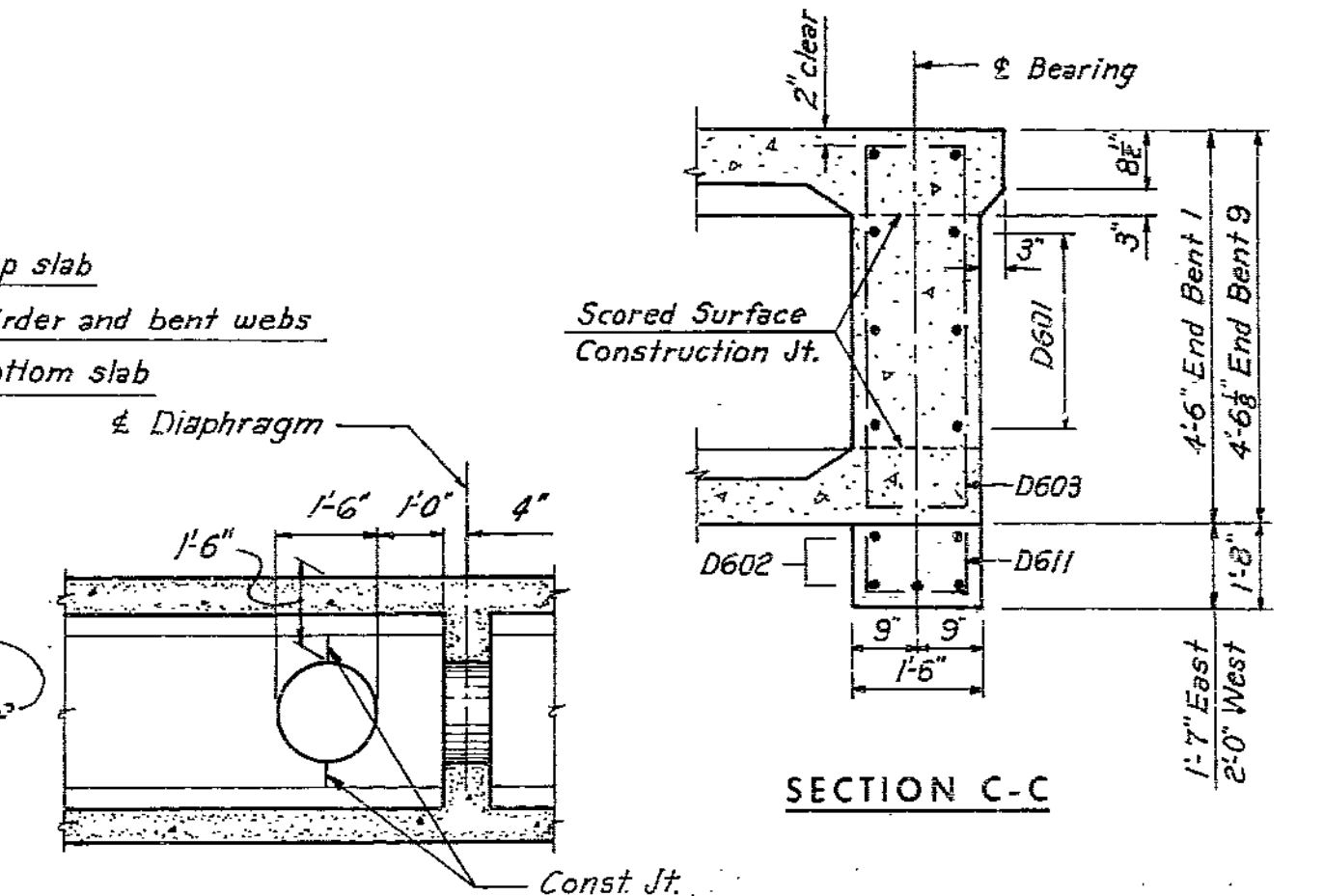

SECTION C-C

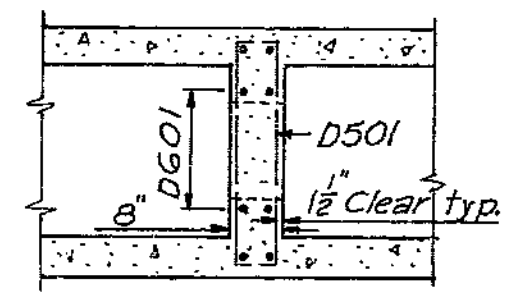

SECTION E-E

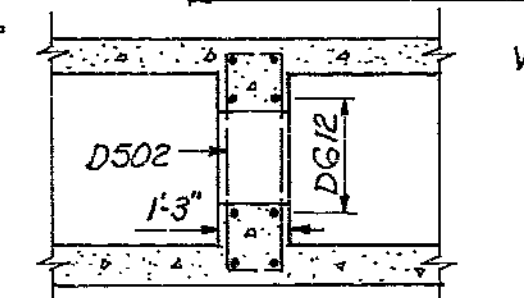

SECTION F-F

GIRDER WEB ACCESS HOLE

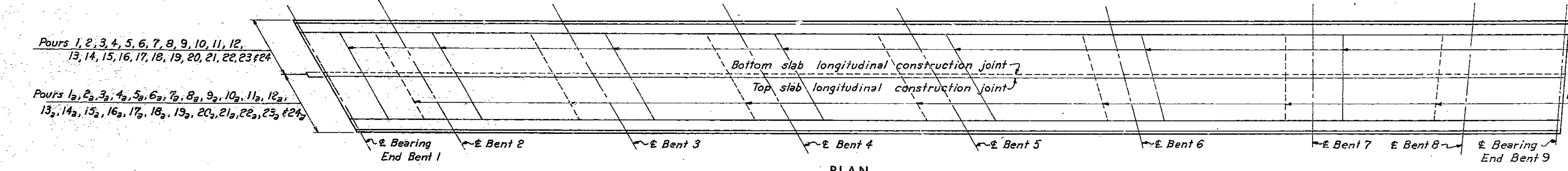

PLAN

Note:
Pour 1₂ shall follow pour 1
and pour 2₂ shall follow pour 2 etc.

POURING SEQUENCE

Note:
For location of sections
B-B, C-C, D-D & E-E see sheet 13.
For location of section
A-A see sheet 9.

BRIDGE : CHARLOTTE STREET UNDERPASS
CROSSTOWN FREEWAY
KANSAS CITY, MO.
PROJECT NO. I-70-1 (41) (RT. I-70) STA. 47+99.11
JACKSON COUNTY
BLANE A

HOWARD, NEEDLES, TAMMEN & BERGENDOFF
CONSULTING ENGINEERS
KANSAS CITY NEW YORK

MADE AGP DATE 10-13-60 TRACED DATE
CHECKED JLW DATE 11-23-60 SCALE

NOTE: This drawing is not to scale. Follow dimensions.

262

MISSOURI STATE HIGHWAY DEPARTMENT

FED. ROAD DIST. NO.	STATE	FEDERAL PROJECT NO. & SEC.	MISCL. SHEET YEAR NO.	TOTAL SHEETS
5	MO.		51	
DIST. NO.	COUNTY	ROUTE	SEC.	
4				

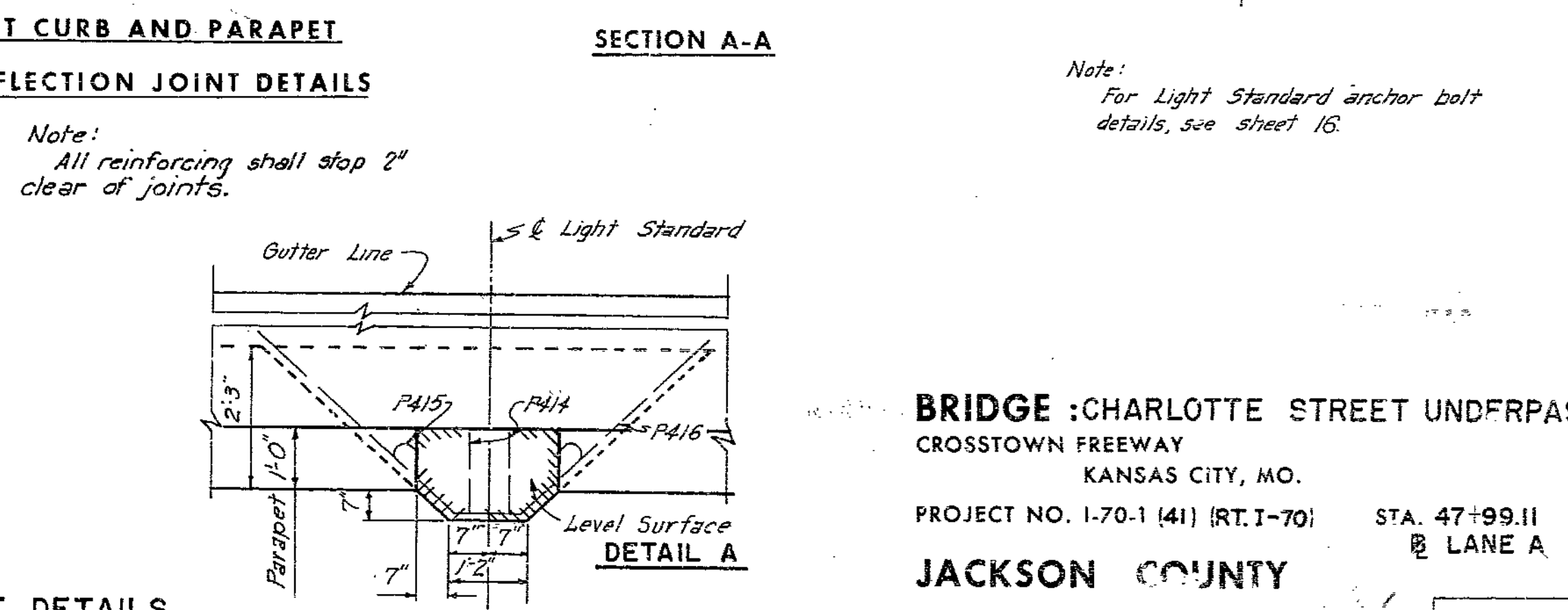
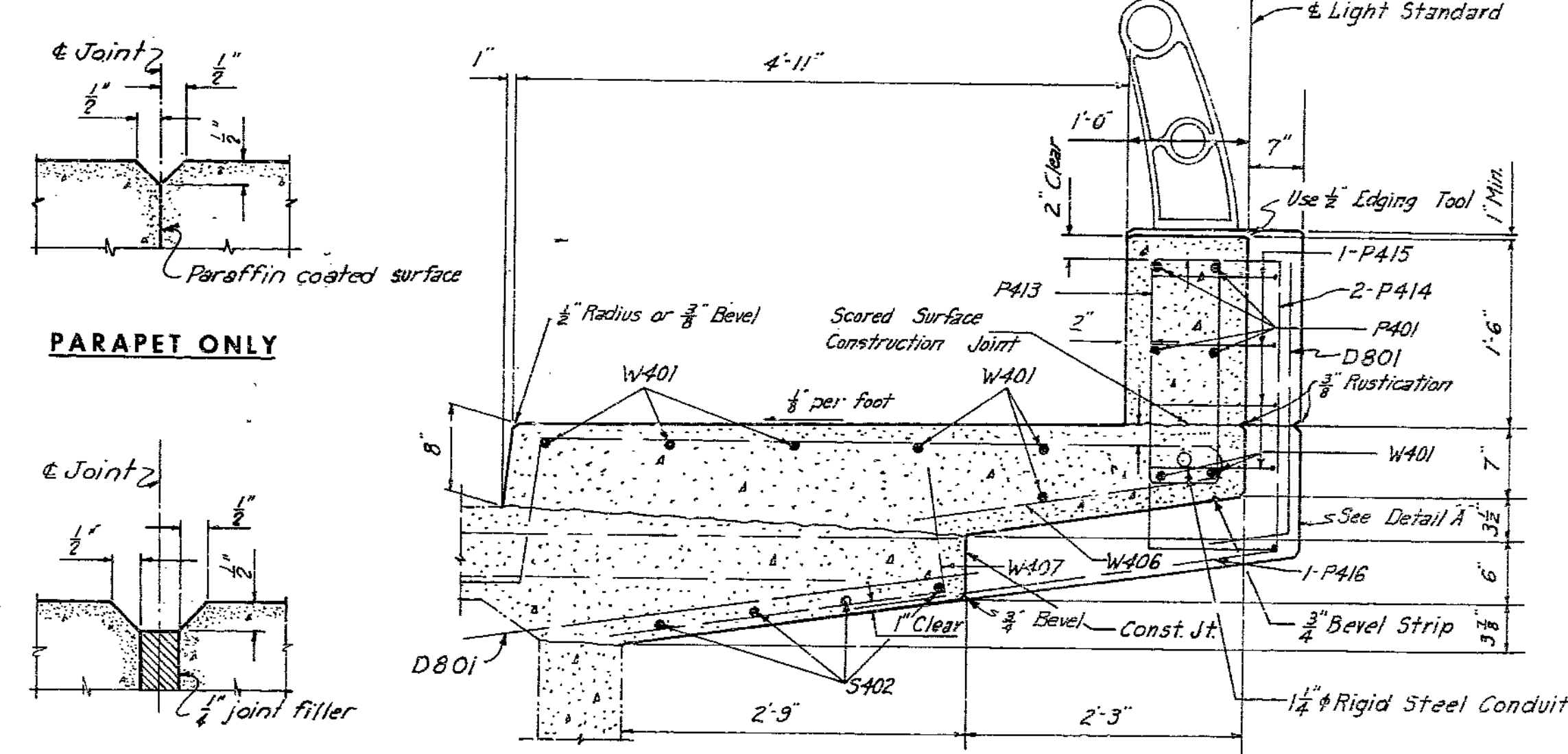
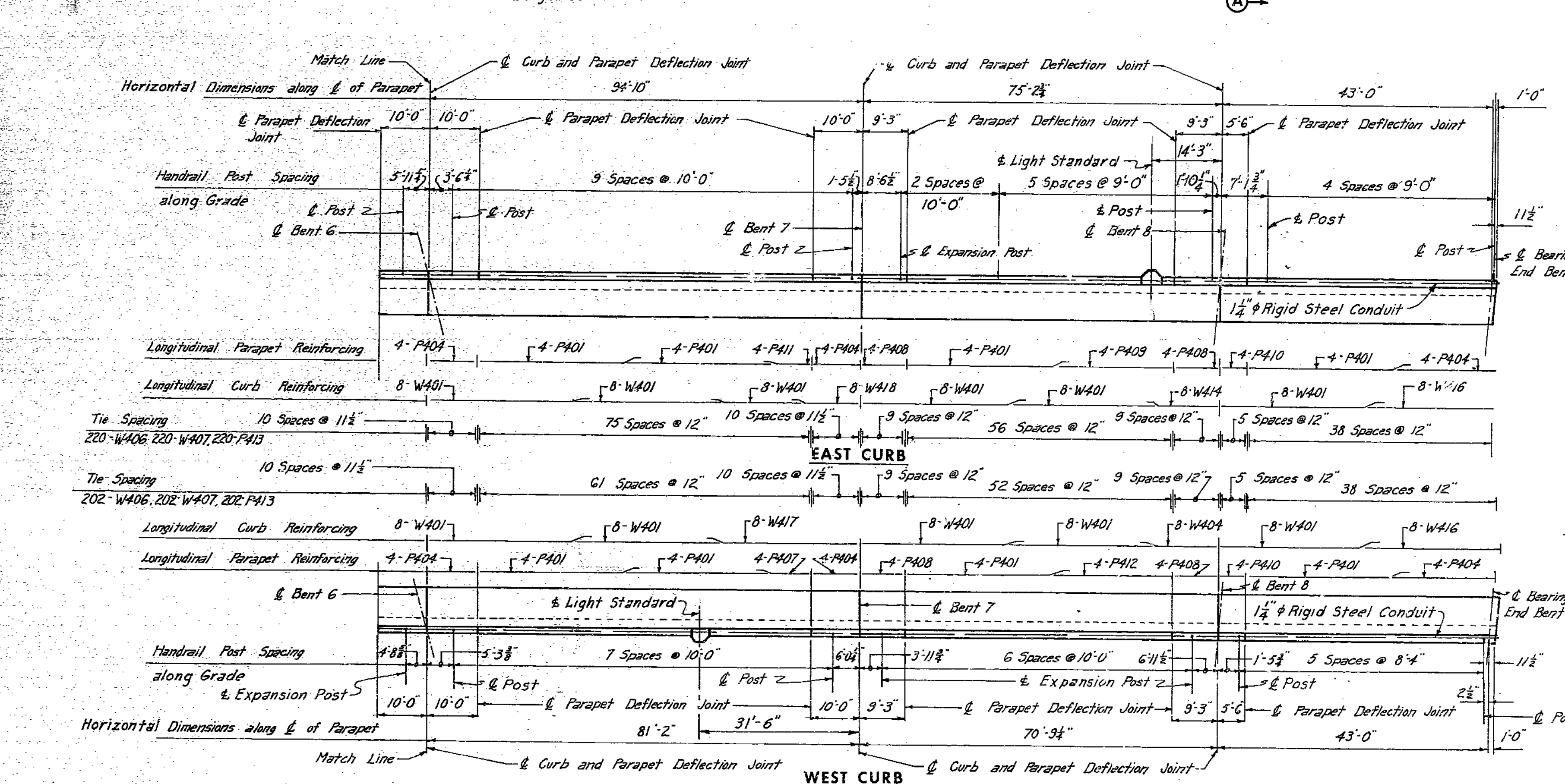
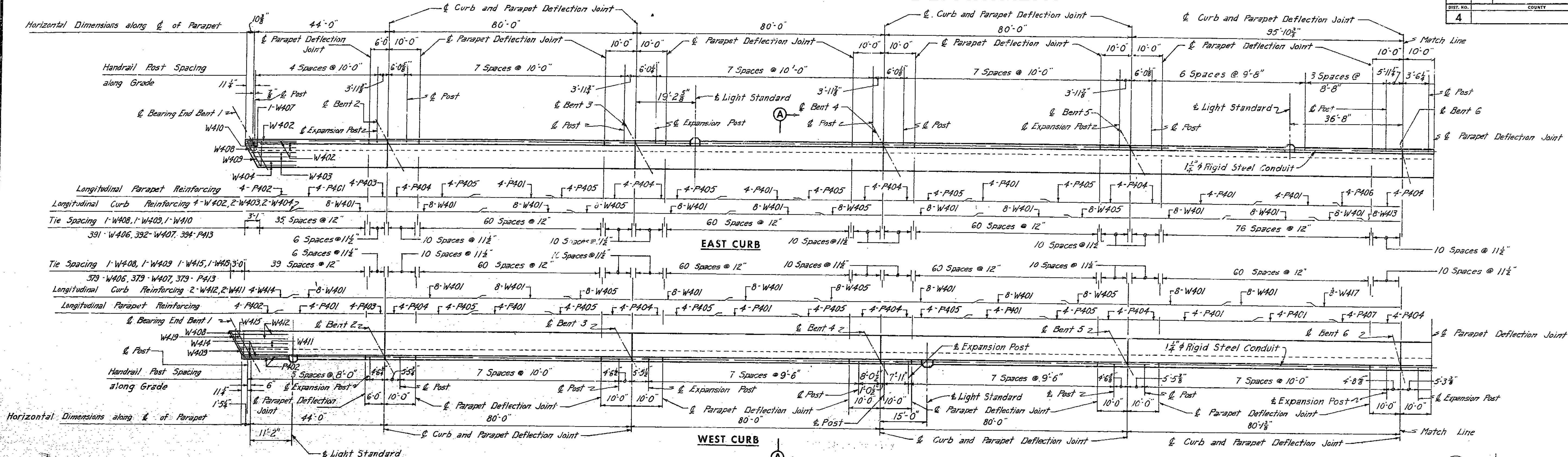

Note:
For Light Standard anchor bolt details, see sheet 16.

Note:
All reinforcing shall stop 2" clear of joints.

BRIDGE : CHARLOTTE STREET UNDERPASS
CROSSTOWN FREEWAY
KANSAS CITY, MO.
PROJECT NO. I-70-1 (41) (RT. I-70) STA. 47+99.11
JACKSON COUNTY LANE A

HOWARD, NEEDLES, TAMMEN & BERGENDOFF
CONSULTING ENGINEERS
KANSAS CITY NEW YORK

NOTE: This drawing is not to scale. Follow dimensions.

SIDEWALK AND PARAPET PLAN

SIDEWALK AND PARAPET DETAILS

MADE RVS DATE 11-8-60 TRACED DATE
CHECKED JLW DATE 11-25-60 SCALE

SHEET 15 OF 18

A-807

263

MISSOURI STATE HIGHWAY DEPARTMENT

FED. ROAD DIST. NO.	STATE	FEDERAL PROJECT NO. & SEC.	FISCAL YEAR	SHEET NO.	TOTAL SHEETS
5	MO			52	
DIST. NO.	COUNTY	ROUTE	SEC.		
4					

Note: For painting see special provisions. Approved stud welded anchors may be used in lieu of #5 bars shown.

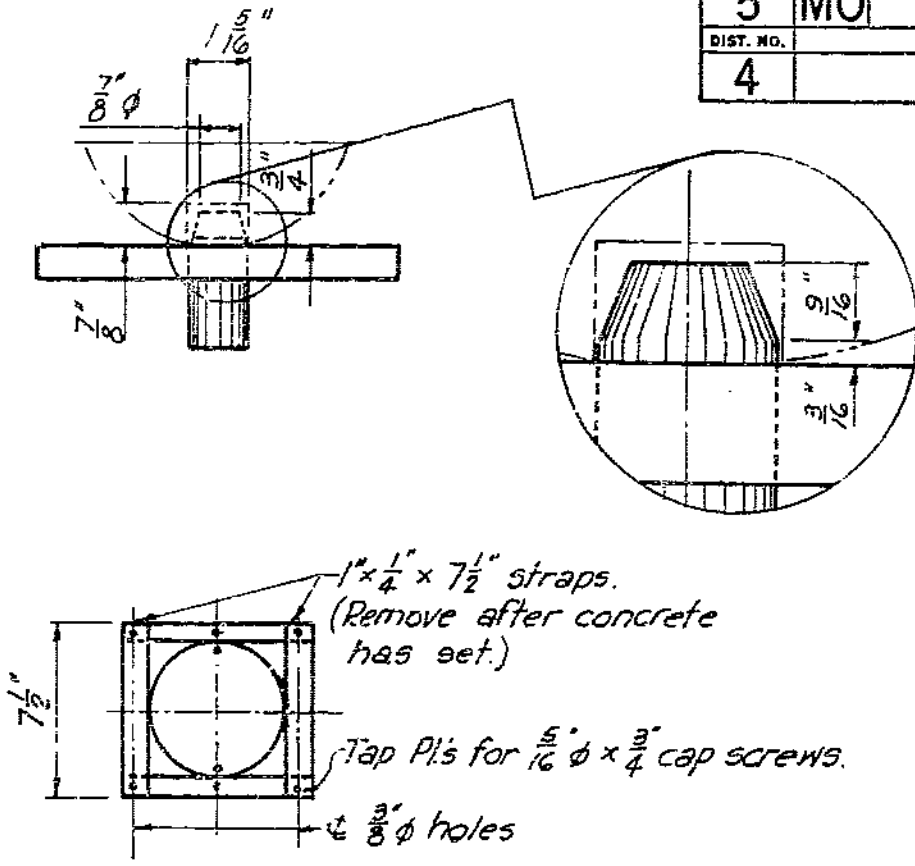
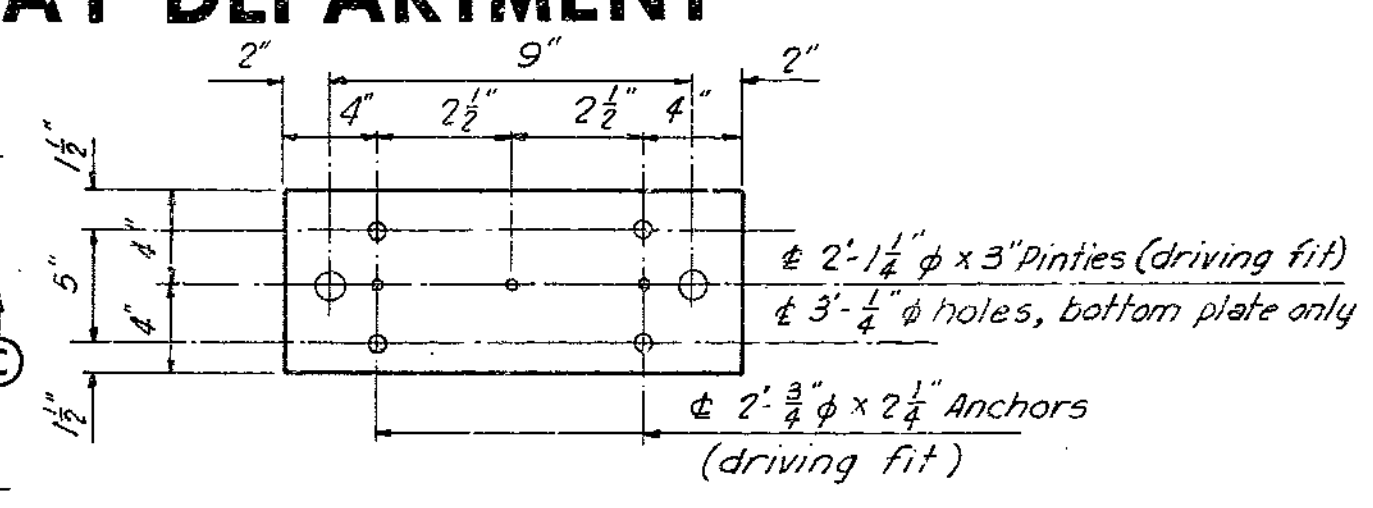
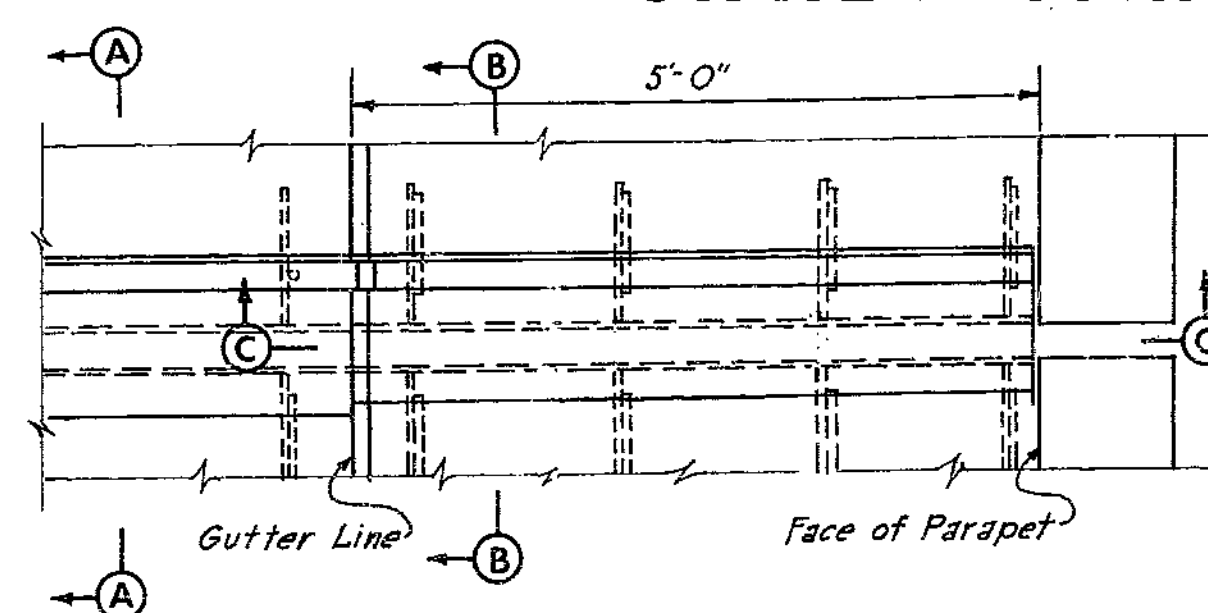
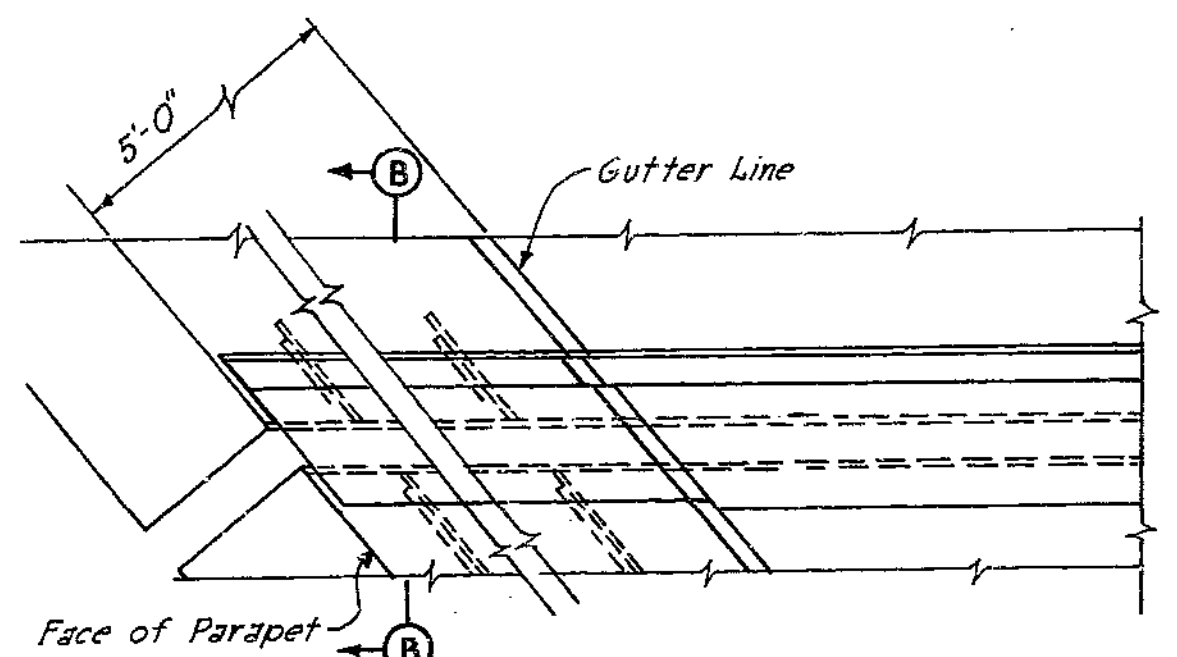

1/2 inch diameter bolts at 60 degree centers (2 per 5'-0 inch sidewalk). Tack weld nut to bottom of angle. Remove bolts within two hours after top slab is poured.

PART PLAN - JOINT SKEWED

PART PLAN - JOINT NORMAL

Note: Top and bottom plates to be USS T-1 Alloy or equivalent. Materials for pinties and rollers shall be cold finished carbon steel A151-C1042 or C1045 (turned and polished). All bearing plates shall be straightened to plane surfaces. E 6015 or E 6016 welding electrodes shall be used. Paint: Shop: One coat red lead except top surface of top plate and bottom surface of bottom plate. Field: All exposed surfaces first coat brown, second coat aluminum.

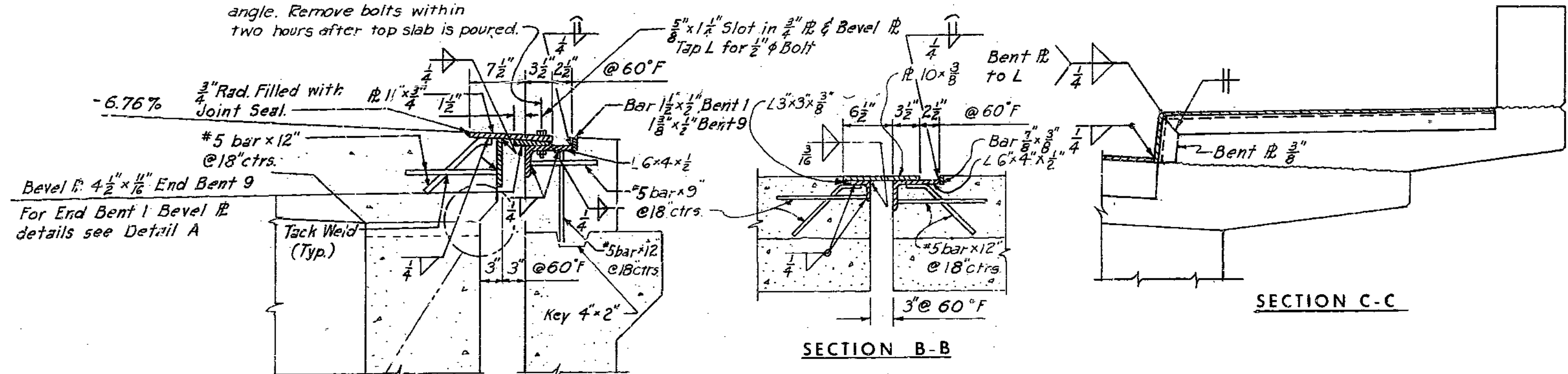

SECTION C-C

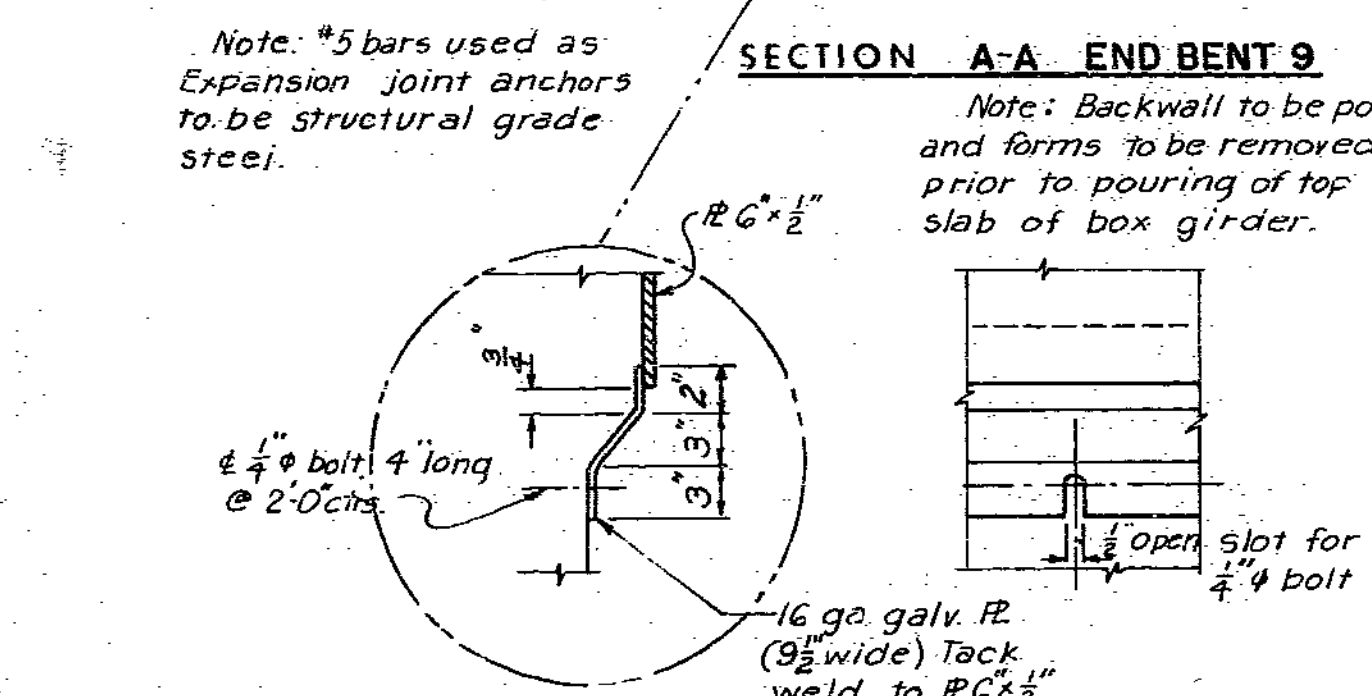

SECTION A-A END BENT 9

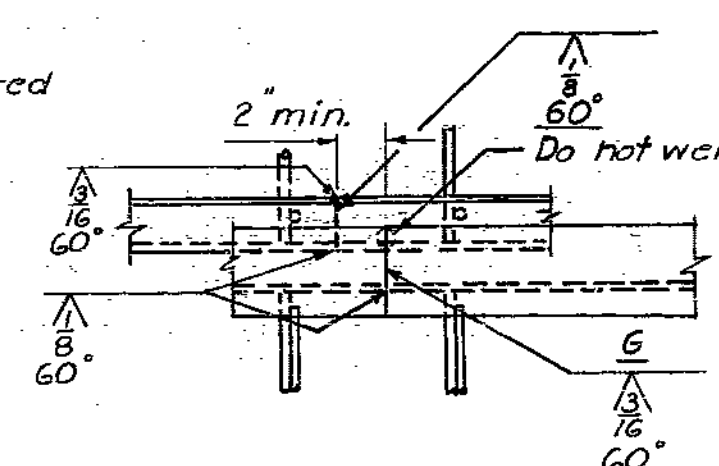

SECTION B-B

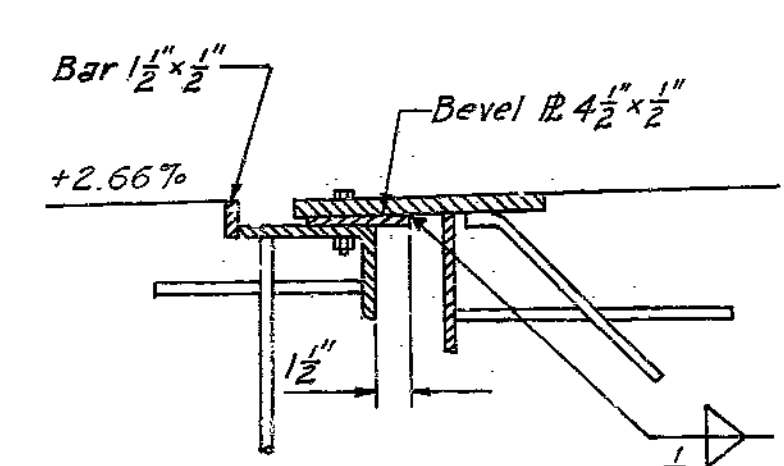

DETAIL A (End Bent 1)

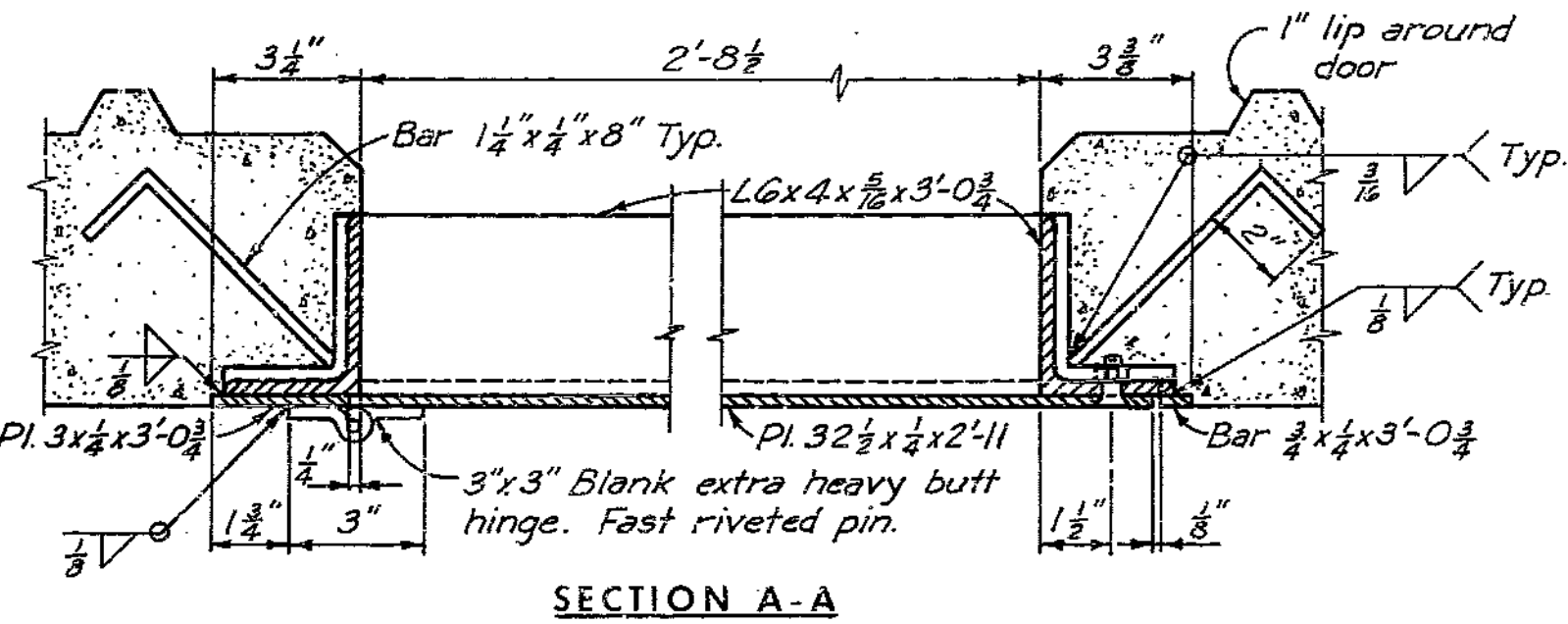

SECTION A-A

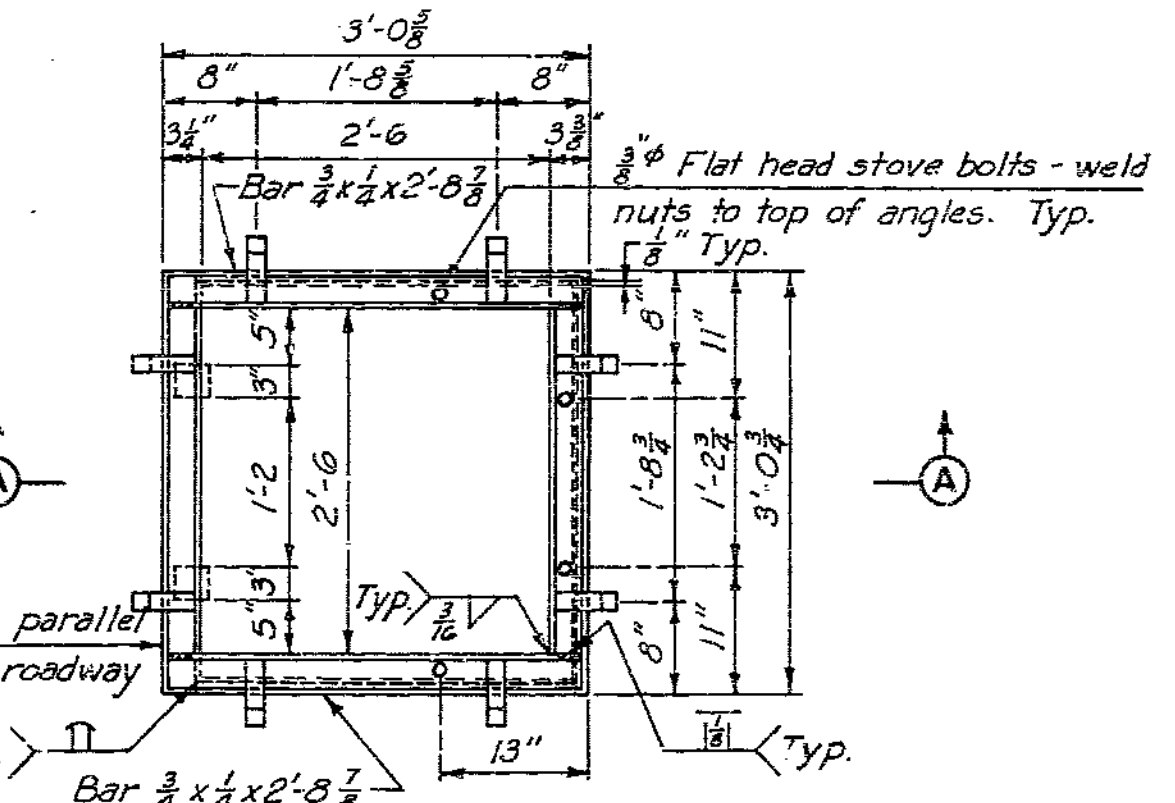

PLAN

Note: Access Doors to be assembled and in place while slab is being poured. Bottom surface of door to be flush with bottom of slab. For painting see special provisions. Payment for furnishing and placing access doors and frames shall be made and considered fully covered under price bid for fabricated structural carbon steel.

BOTTOM SLAB ACCESS DOOR DETAILS

No. of Doors Required (16). Note: Weight of one door and frame is approximately 181 lbs.

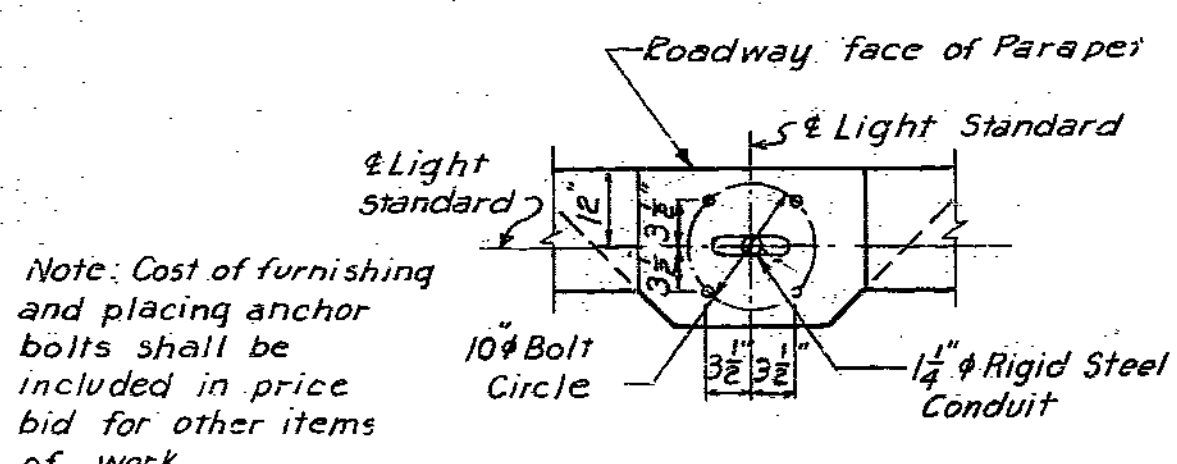

ANCHOR BOLT SETTING PLAN

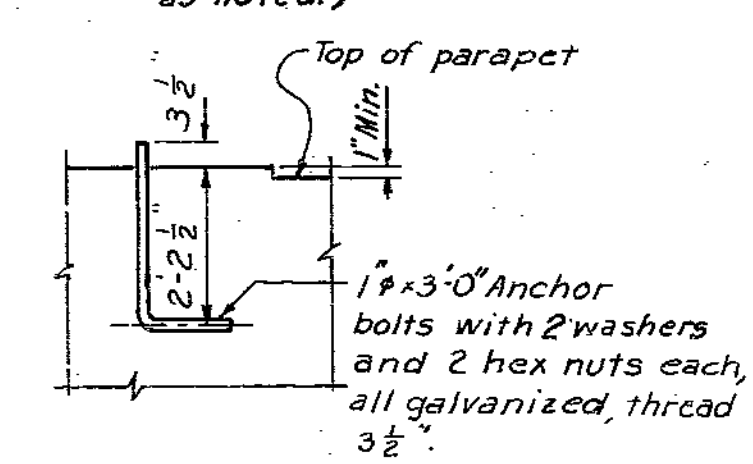

ANCHOR BOLT DETAIL

LIGHT STANDARD DETAILS

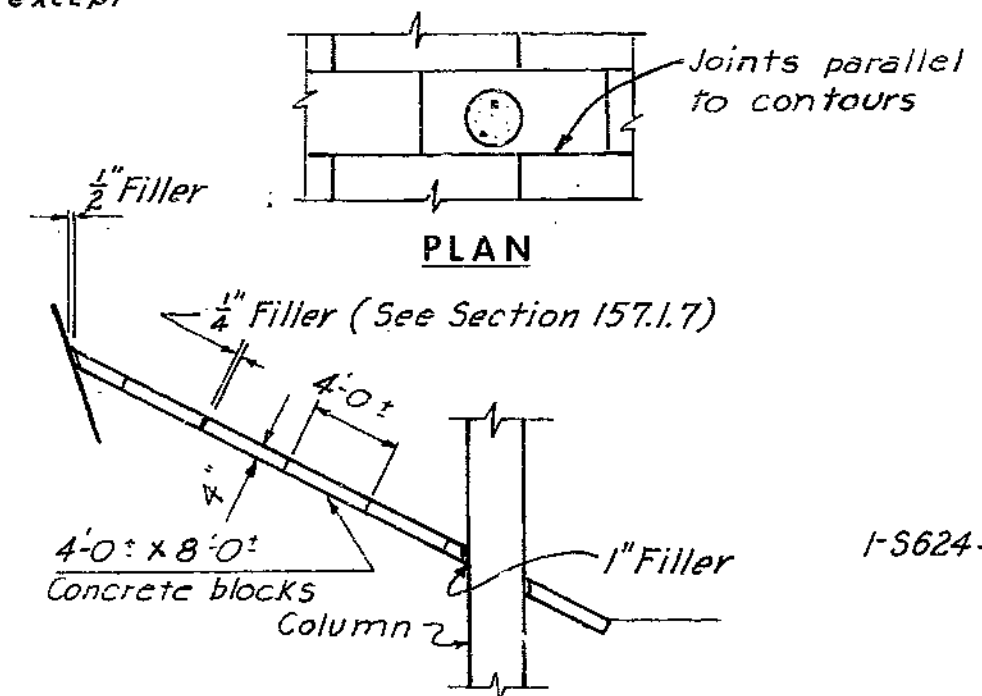

SLOPE PROTECTION

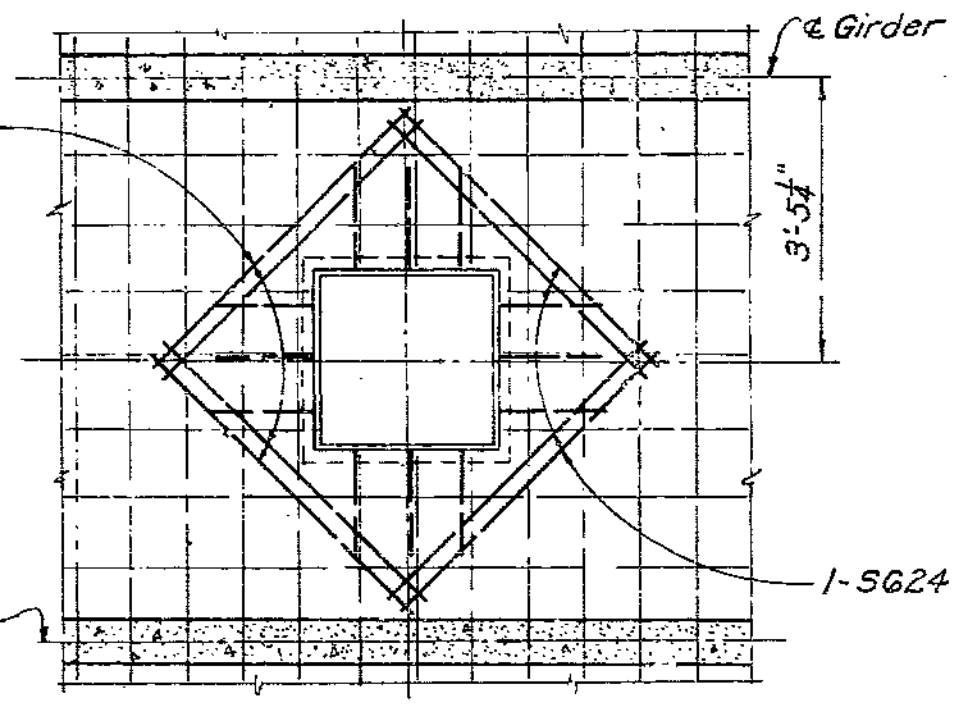

REINFORCING AT ACCESS DOOR

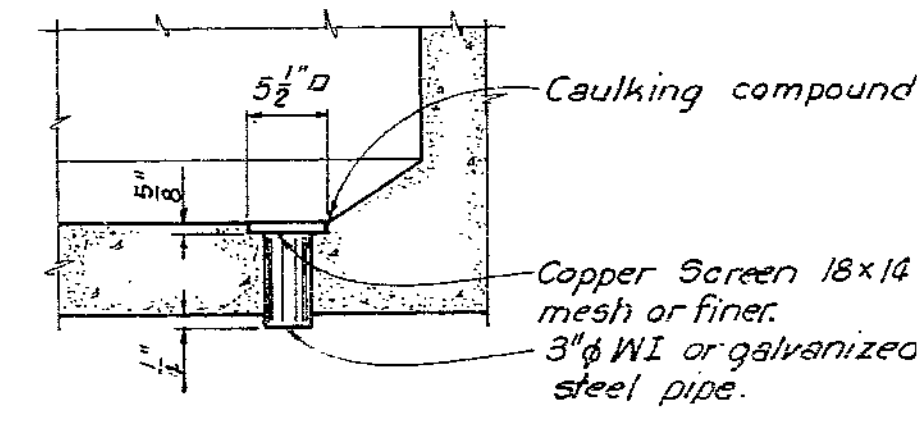

BOTTOM SLAB DRAIN

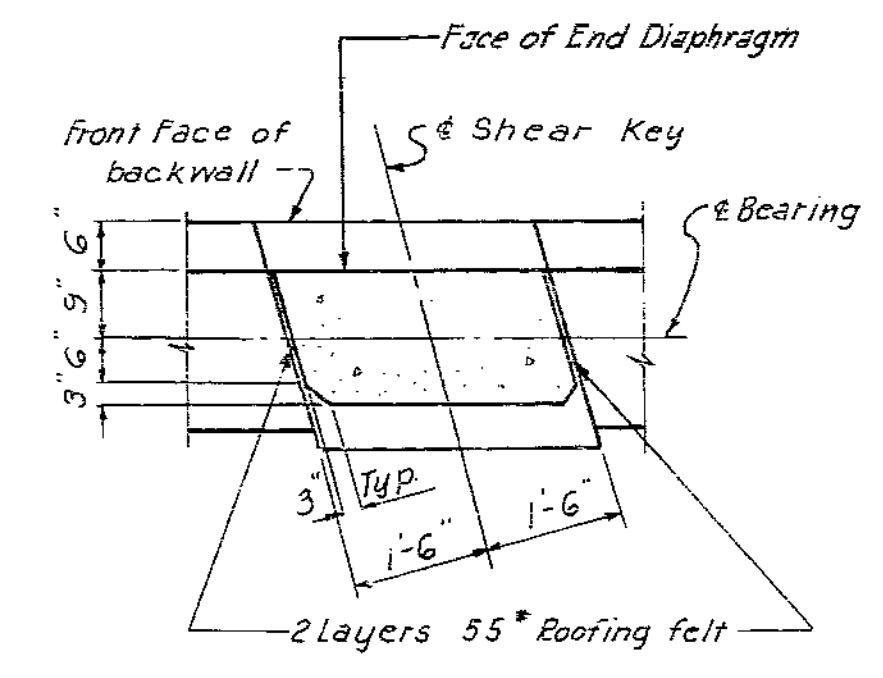

SHEAR KEY DETAIL

Note: If galvanized steel pipe is used, the screen shall be aluminum. Cost of furnishing and placing pipe, screen, and caulking compound shall be included in price bid for other items of work.

MISCELLANEOUS DETAILS

Note: Cost of furnishing and placing anchor bolts shall be included in price bid for other items of work.

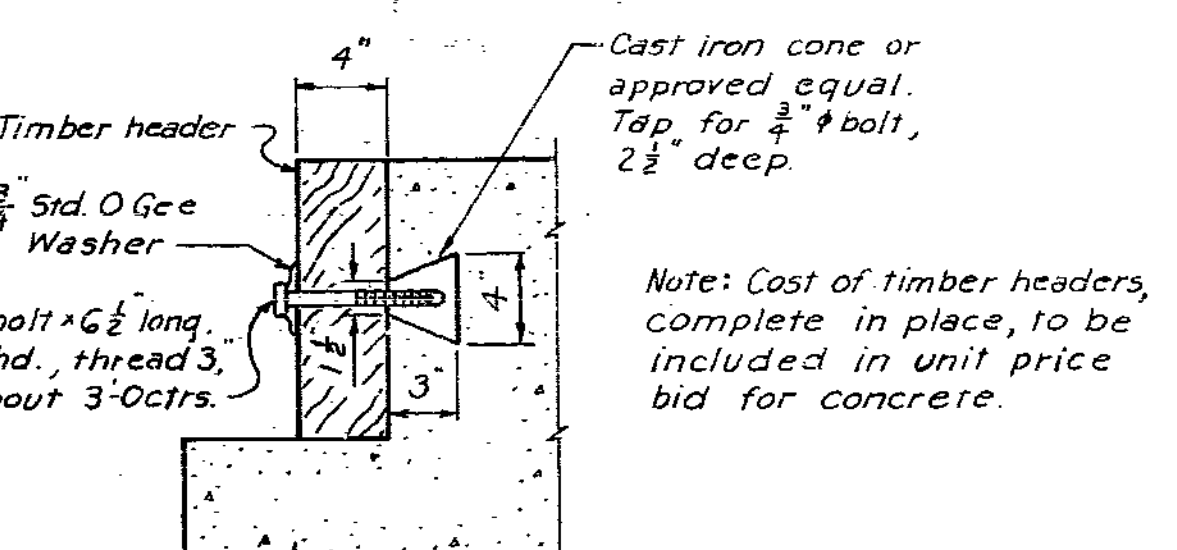

TIMBER HEADER DETAIL

PILE SPlice DETAIL

BRIDGE: CHARLOTTE STREET UNDERPASS, CROSSTOWN FREEWAY, KANSAS CITY, MO.

PROJECT NO. 1-70-1 (41) [RT. I-70] STA. 47+99.11

JACKSON COUNTY, MISSOURI, BLANE A

SHEET 16 OF 18

A-807

264

HOWARD, NEEDLES, TAMMEN & BERGENDOFF CONSULTING ENGINEERS		NEW YORK	
MADE BY	DATE	TRACED BY	DATE
CHKD BY	DATE	SCALE	

NOTE: This drawing is not to scale. Follow dimensions.

MISSOURI STATE HIGHWAY DEPARTMENT

FED. ROAD DIST. NO.	STATE	FEDERAL PROJECT NO. & SEC.	FISCAL YEAR	SHEET NO.	TOTAL SHEETS
5	MO			53	
DIST. NO.		COUNTY	ROUTE	SECTION	
4					

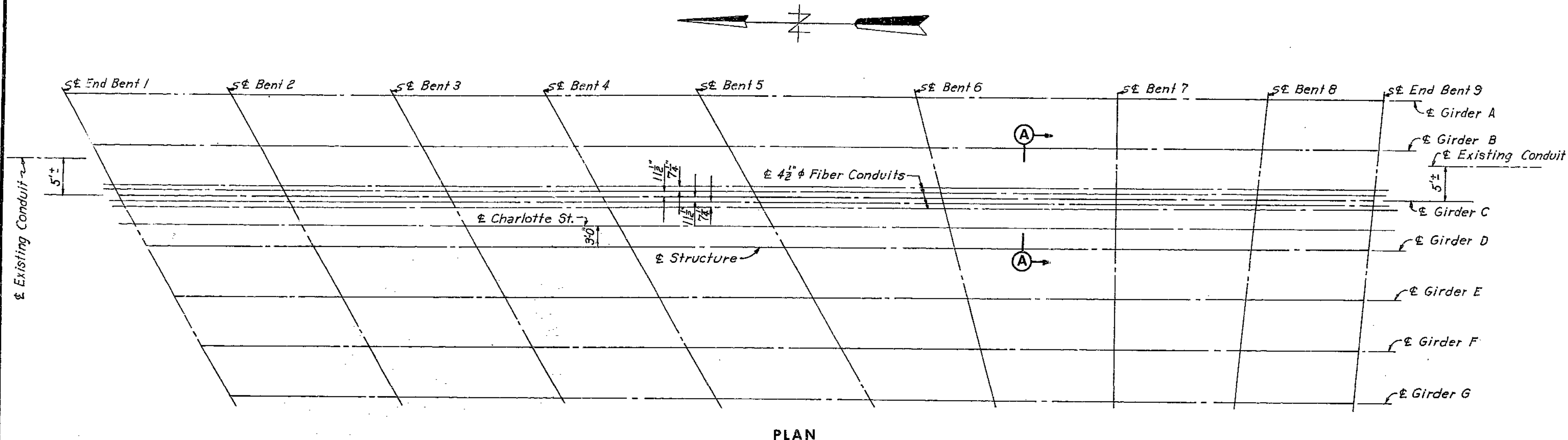

PLAN

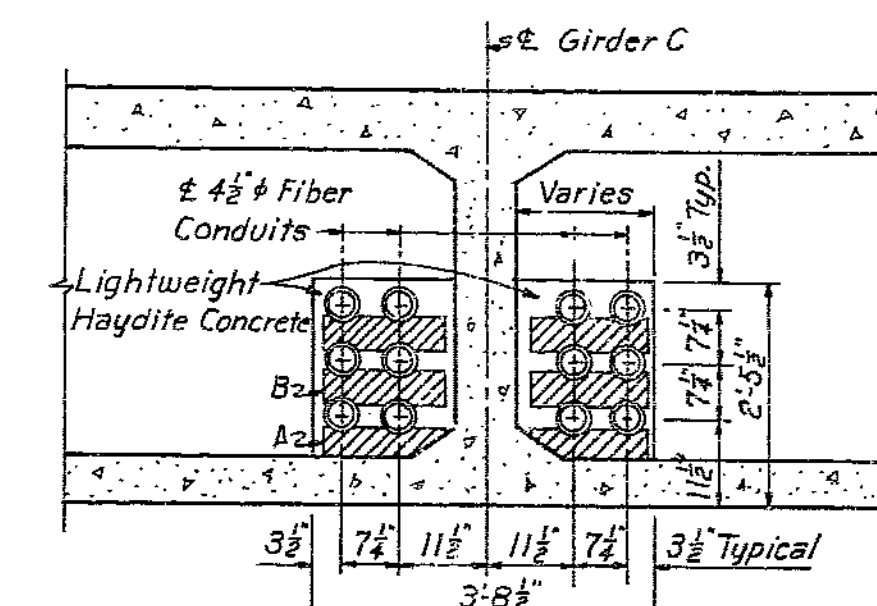

SECTION A-A

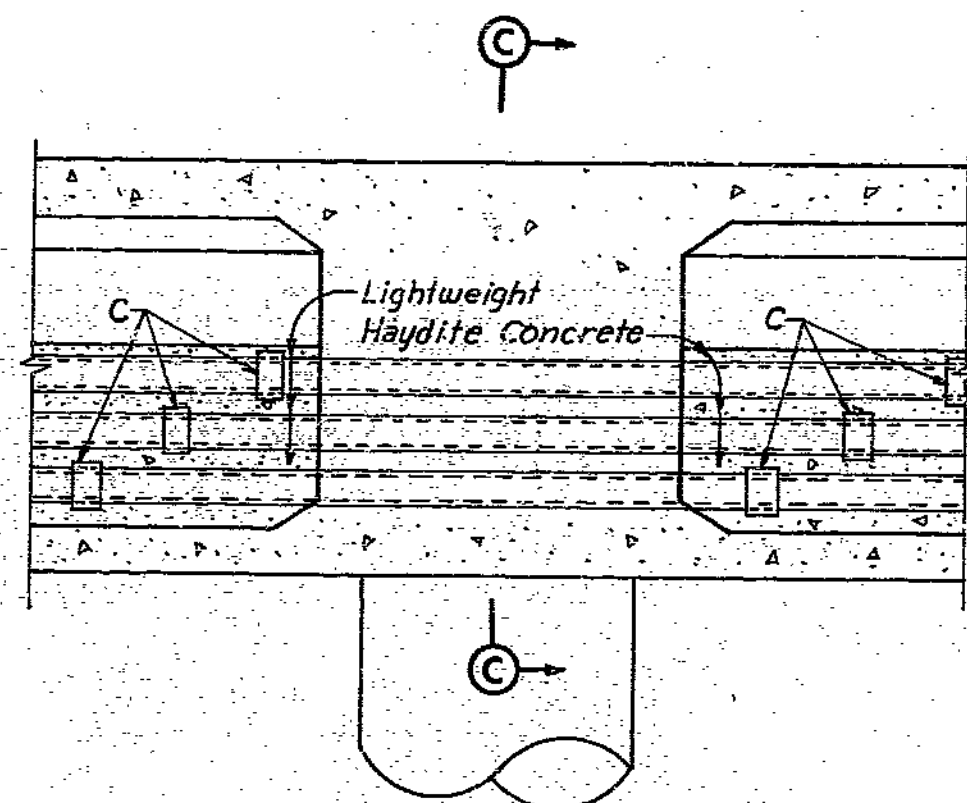

SECTION THRU BENTS 2 THRU 8

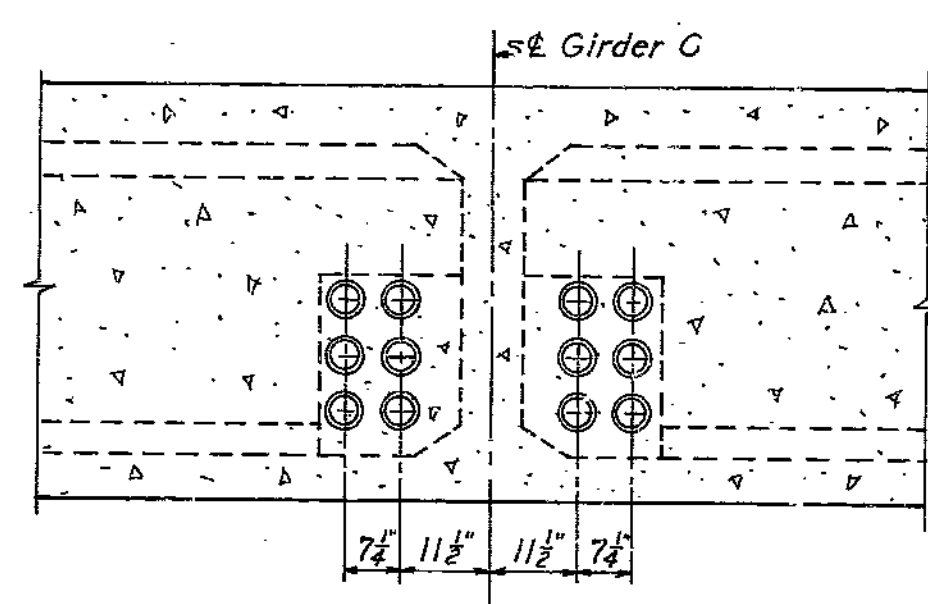

SECTION C-C

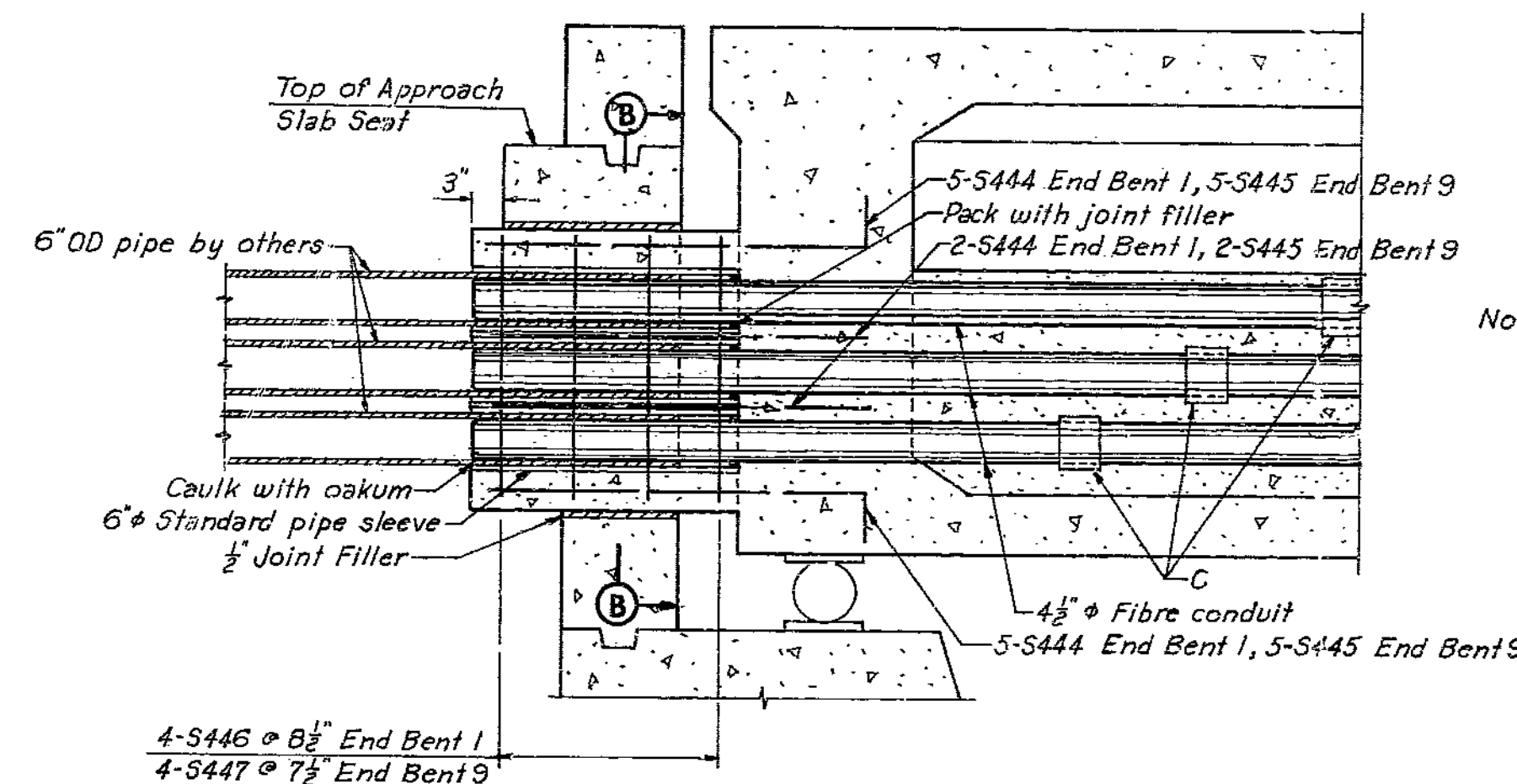

SECTION THRU END BENT 1
(End Bent 9 Similar)

Note: Payment for 6" Standard Pipe sleeve shall be made under conduit system for Kansas City Power and Light Co.

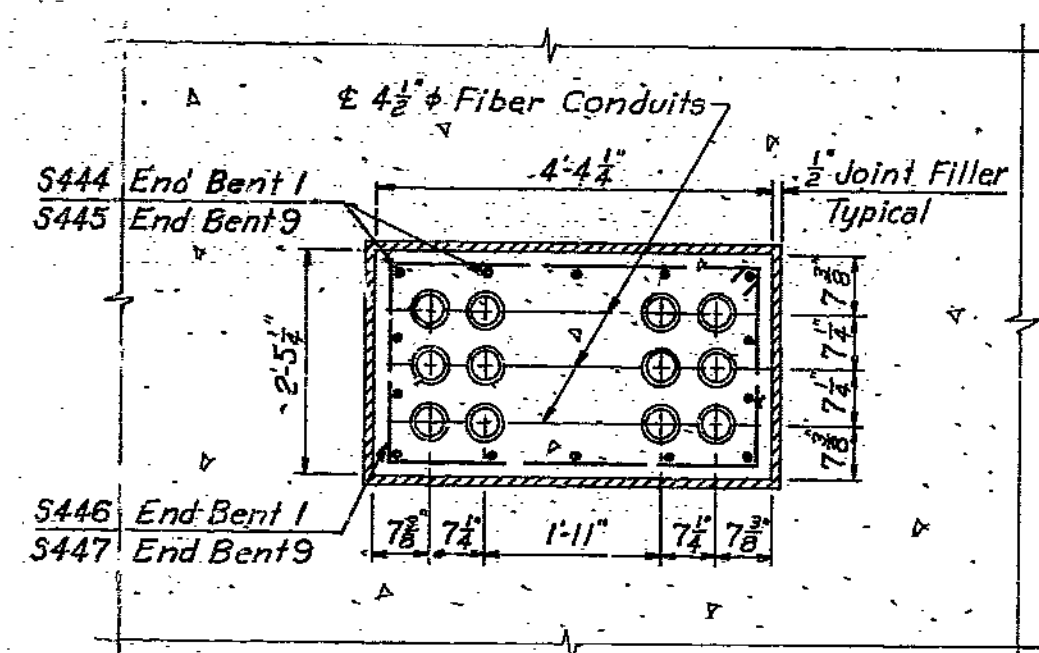

SECTION B-B

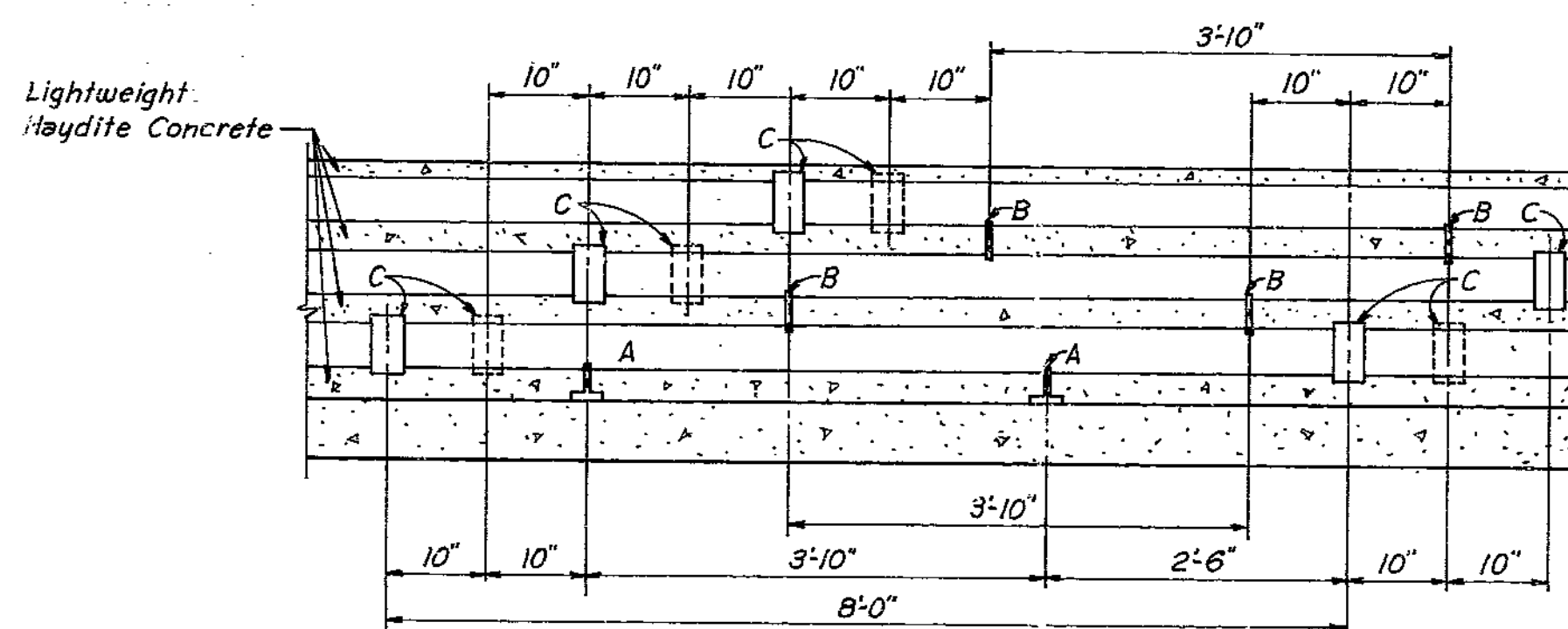

CONDUIT CONSTRUCTION DETAILS

BILL OF REINFORCEMENT							
No.	Size	Length	Mark	Type	A	B	C
* 14	4	4'-6"	S444	104	4'-0"	6"	
* 14	4	4'-1"	S445	104	3'-5"	6"	
* 4	4	14'-6"	S446	109	4'-8"	2'-2"	5"
* 4	4	13'-4"	S447	109	4'-1"	2'-2"	5"
					104		109

* Included in lump sum bid for Kansas City Power and Light Conduit System and not included in Estimated Quantities and Bills of Reinforcing Steel.

Legend:
A - refers to Fiber Base Block.
B - refers to Fiber Spacer Block.
C - refers to Duct Joints.

NOTE: This drawing is not to scale. Follow dimensions.

HOWARD, NEEDLES, TAMMEN & BERGENDOFF
CONSULTING ENGINEERS
KANSAS CITY NEW YORK

MADE BY	DATE	TRACED BY	DATE
RGP	1-10-61		
CHECKED BY	DATE	SCALE	
JLW	5-11-61		

BRIDGE: CHARLOTTE STREET UNDERPASS
CROSSTOWN FREEWAY
KANSAS CITY, MO.
PROJECT NO. I-70-1 (41) (RT. I-70) STA. 47+99.11
LANE A
JACKSON COUNTY

CONDUIT SYSTEM DETAILS

SHEET 17 OF 18

A-807

265

NO CONSTRUCTION

MISSOURI STATE HIGHWAY DEPARTMENT

FED. ROAD DIV. NO.	STATE	FEDERAL PROJECT NO. & SEC.	FISCAL YEAR	SHEET NO.	TOTAL SHEETS
5	MO			54	
DIST. NO.	COUNTY	ROUTE	SEC.		
4					

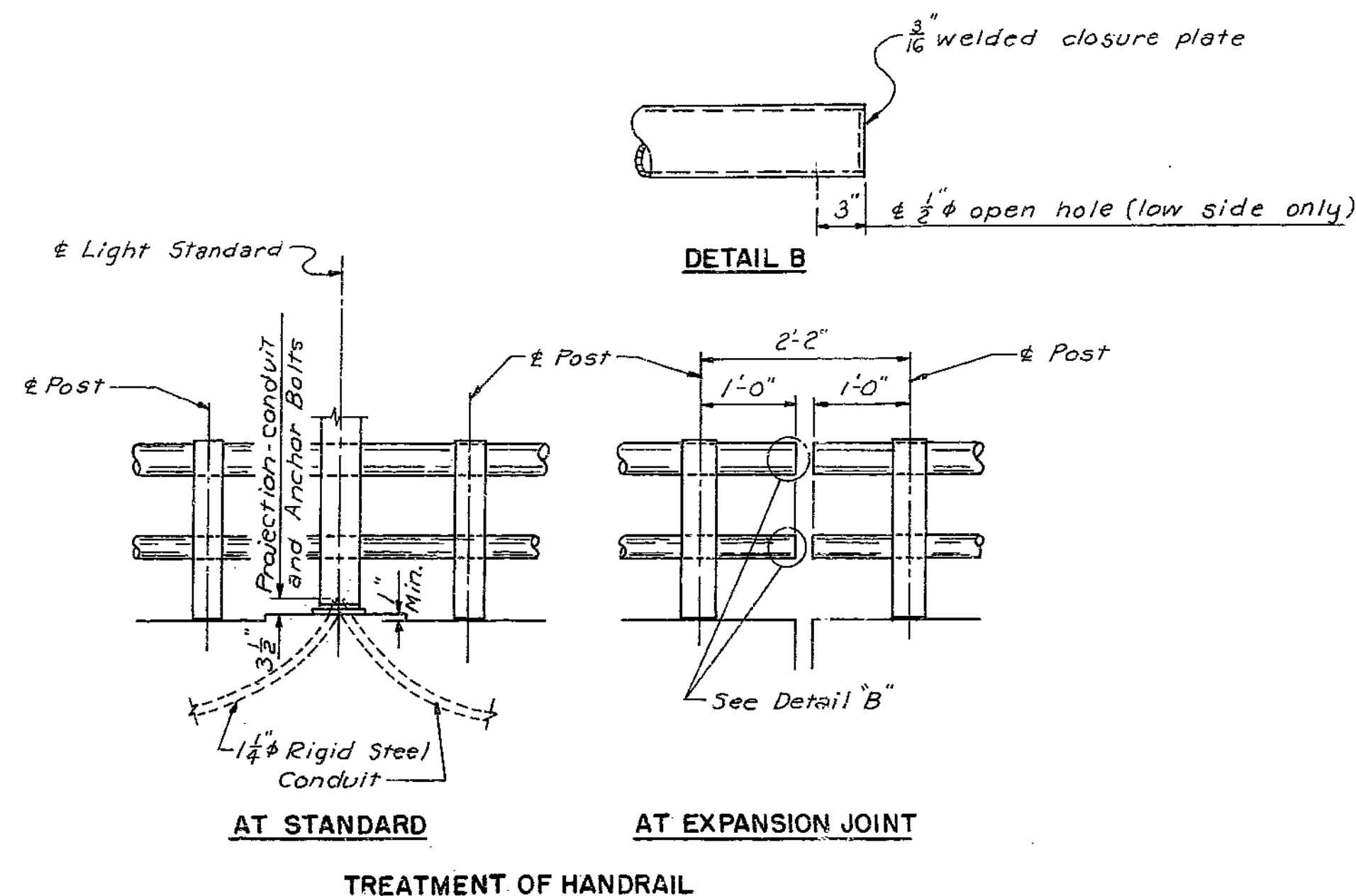

Note: All handrail posts shall be set normal to grade.
 Aluminum tube handrail shall be bent to conform to vertical and horizontal alignment of parapet.
 Aluminum washer shims between top of parapet and post base may be used for adjusting handrail alignment. Maximum thickness of shims to be 1/8". Where more tilting of post is required for proper alignment, concrete bearing areas shall be ground down.
 All parts of handrail, except anchor bolts, nuts, washers and set screws are to be of aluminum material.
 The contract unit price per linear foot of Bridge Rail shall include furnishing and erecting the handrail complete with anchor bolts, shims and insulating compound.
 All fillets 1/4" except as noted.
 All draft 3° except as noted.
 Rails to be fabricated in two or three panel lengths unless otherwise approved.
 Omit set screw on side near filled joint in parapet at all expansion posts.

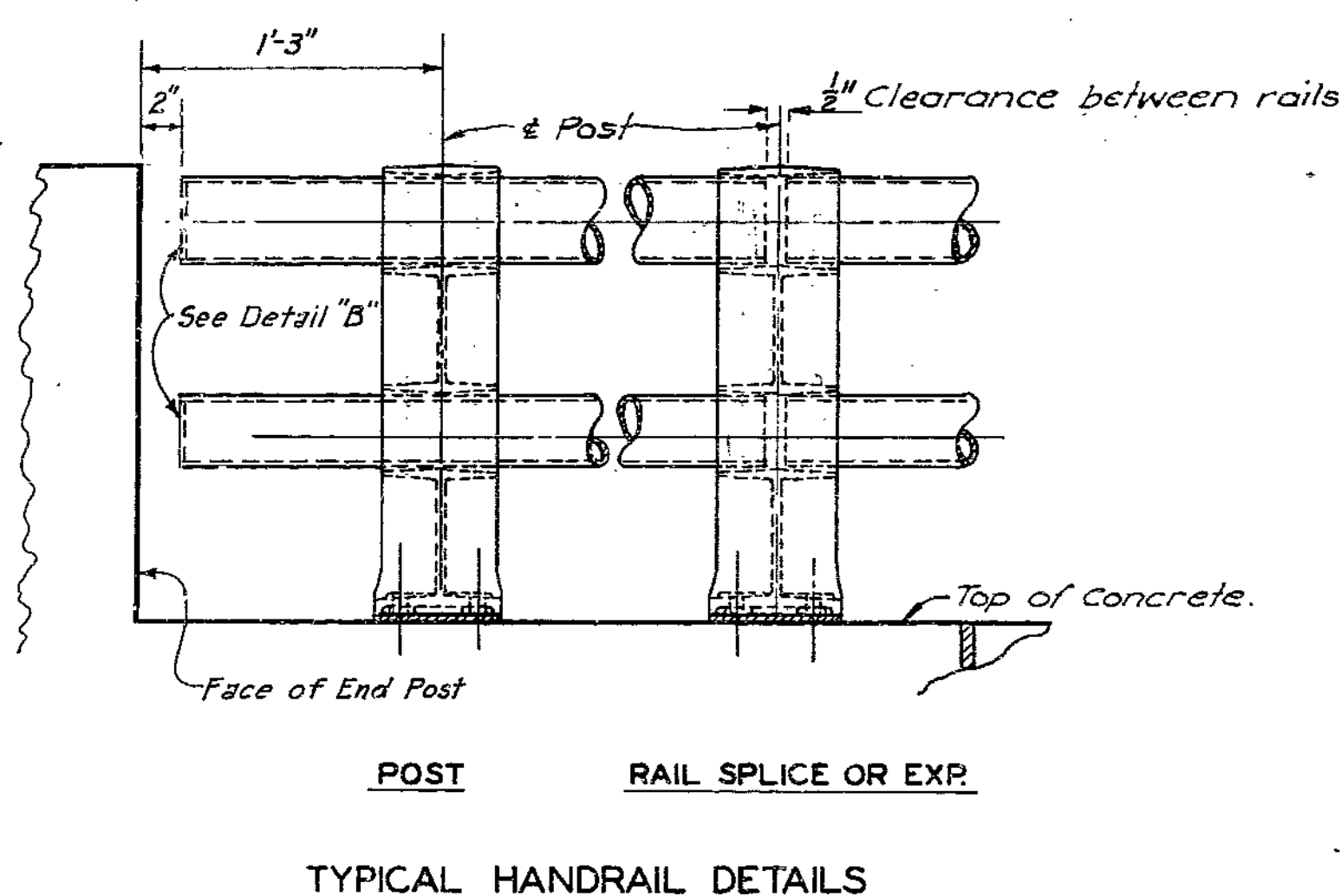
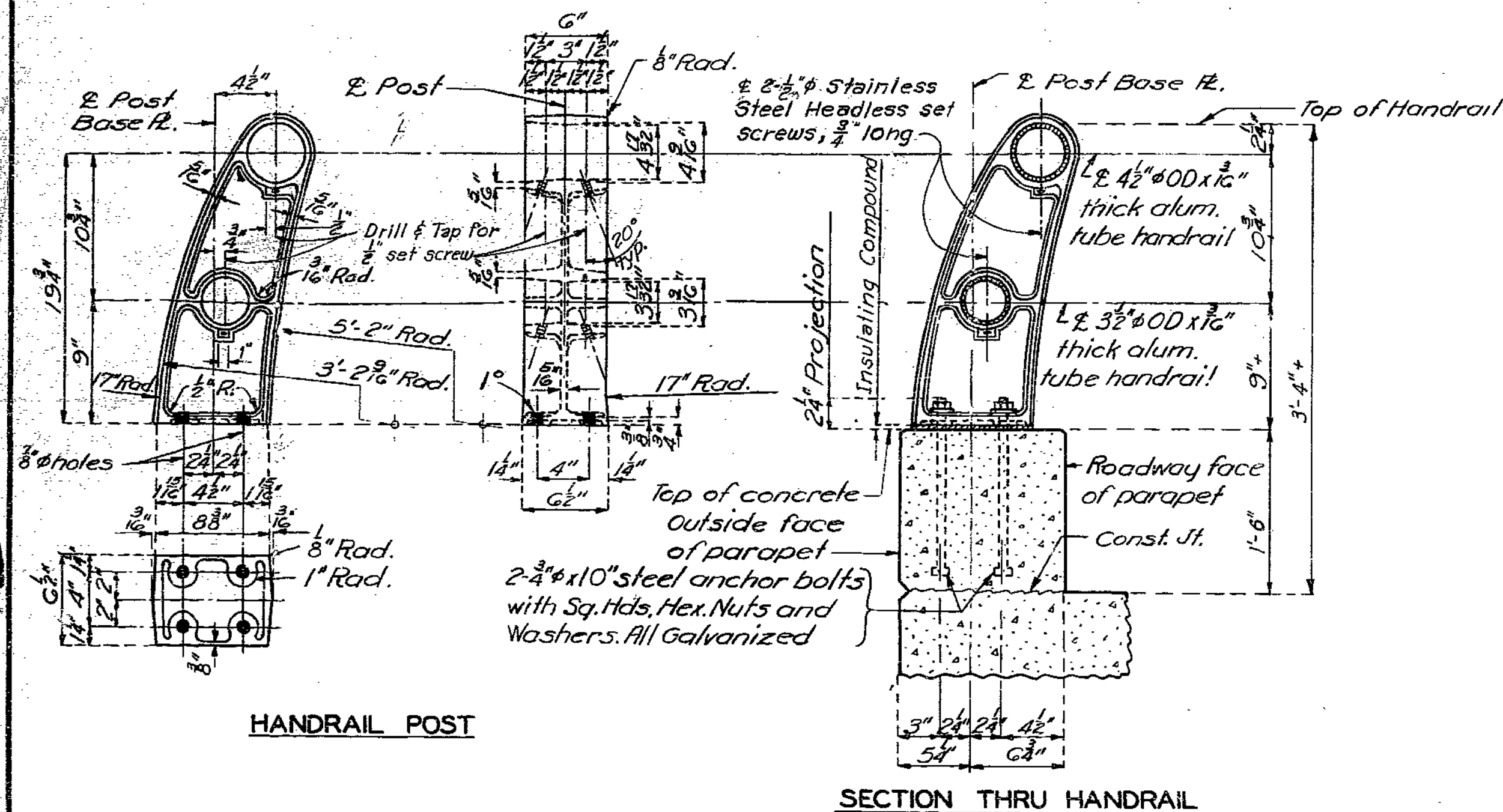

DOUBLE TUBE ALUMINUM RAILING

HOWARD, NEEDLES, TAMMEN & BERGENDOFF
 CONSULTING ENGINEERS
 KANSAS CITY NEW YORK

MADE	JLW	DATE	11-25-60	TRACED	DATE
CHECKED	FVS	DATE	11-25-60	SCALE	

STANDARD HANDRAIL DETAILS

BRIDGE : CHARLOTTE STREET UNDERPASS
 CROSSTOWN FREEWAY
 KANSAS CITY, MO.

PROJECT NO. 1-70-1 (41) (RT. I-70) STA. 47+99.11
 LANE A

JACKSON COUNTY

SHEET 18 OF 18

A-807

266

MISSOURI STATE HIGHWAY DEPARTMENT

FED. ROAD DIST. NO.	STATE FEDERAL PROJECT NO. & SEC.	FISCAL YEAR	SHEET NO.	TOTAL SHEETS
5	MO. I-70-1(4)2		37	
SHT. NO.	COUNTY	ROUTE	SEC.	
4	JACKSON	I-70		

FINAL PLANS

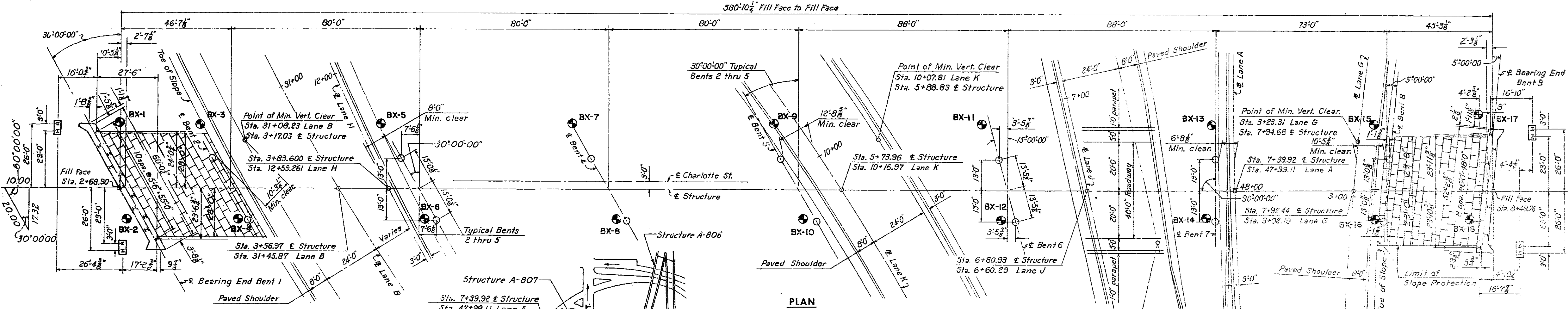
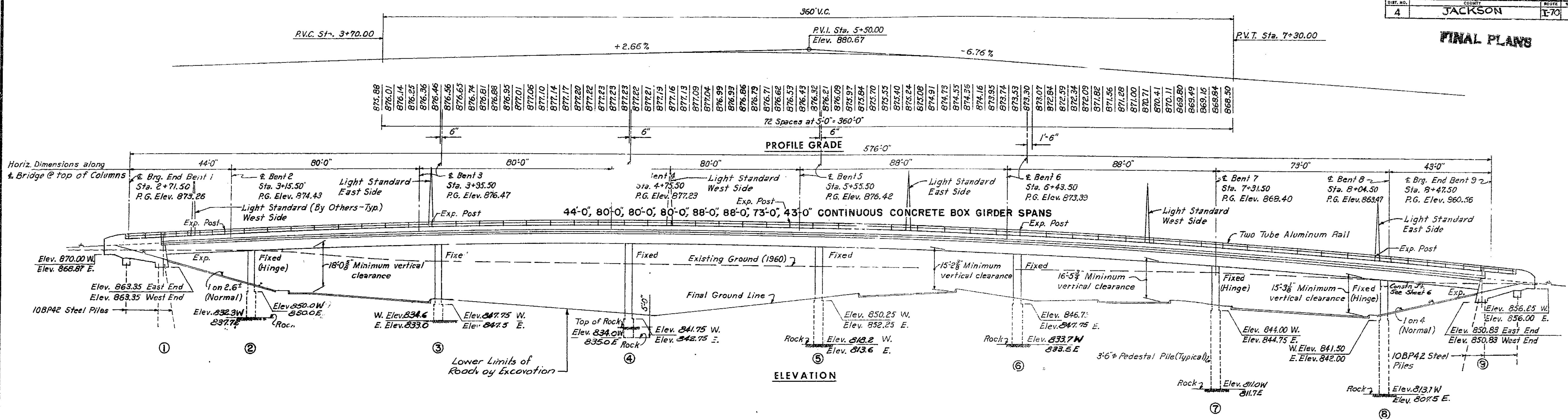

BENCH MARK: Chiseled square on Northeast Corner of Northwest Wingwall Sidewalk 873.30.

HOWARD, NEEDLES, TAMMEN & BERGENDOFF
CONSULTING ENGINEERS
KANSAS CITY NEW YORK

MADE RGP DATE 10-27-60 TRACED DATE
CHECKED JLV DATE 11-25-60 SCALE

LOCATION SKETCH

NOTE: This drawing is not to scale. Follow dimensions.

GENERAL PLAN AND ELEVATION

SHEET 1A of 3

FINAL PLANS

SUBMITTED BY: *E. J. Bergendoff*
REGISTERED PROFESSIONAL ENGINEER MISSOURI NO. E-253
BRIDGE: CHARLOTTE STREET UNDERPASS
CROSSTOWN FREEWAY
KANSAS CITY, MO.
PROJECT NO. I-70-1(4)1(RT. I-70) STA. 47+99.11
JACKSON COUNTY & LANE A
SUBMITTED BY: *D. B. Johnson* DATE 7/6/61 STD 54.00
BRIDGE ENGINEER
APPROVED BY: *J. J. Corbett* DATE 7/6/61 A-807
CHIEF ENGINEER

267

MISSOURI STATE HIGHWAY DEPARTMENT

Table with project details: STATE FEDERAL PROJECT NO. 8 SEC. 5 MO. I-70-1(4)2, COUNTY JACKSON, SHEET NO. 38, TOTAL SHEETS 40.

GENERAL NOTES

Design Specifications: A.A.S.H.O. 1957 with tentative revisions for 1958 and 1959.

Design Loading: H 20-516-44 and alternate loading designated in P.R.M. 20-4 Sec. 4c. 15 #/sq. ft. future wearing surface.

Concrete: Concrete stress: Class B1 fc = 1,600 psi, Class B fc = 1,200 psi. Concrete for superstructure is Class B1 air-entrained. Concrete for pedestal piles and end bents is Class B air-entrained.

Reinforcing Steel: Allowable stress 20,000 p.s.i. All splices in reinforcing steel are 32 bar diameters. Bar sizes are designated on the plans by numbers. The first digit after the letter in three digit marks is the first two digits after the letter in four digit marks indicate the size of the bar.

Joint Filler: Where joint filler is specified on the plans it does conform with the requirements for gray sponge rubber compound joints as given in Section 157.2.4 of the Standard Specifications.

Piling: All piles do conform with details and notes on Sheet No. 16. All piles required for this structure were furnished by the State. (See special provisions). All piles were driven to or into solid rock, boulders, shale or cemented gravel, or to not less than full length authorized, and to sustain a load of at least 37 tons per pile for 10 BP-42. All piles were driven with a power hammer. See section 52.47 of Standard Specifications, for required painting of steel piles.

Steel Conduits: Expansion sleeves are steel/conduit at all expansion joints. Expansion sleeves are QZ Electrical Manufacturing Company type 125 with AJ bonding jumper or equal.

Welding: Qualification of welding operators required.

Sealing of Decks: Superstructure deck is surface sealed. See Special Provisions.

Utilities: All utilities, unless shown otherwise, were removed or noted by others. Contractor shall notify the owner of the utilities of his work schedule sufficiently in advance to allow time for the disposition of utilities.

Shipping: Permits were obtained for all truck loads over legal length.

Excavation to Rock: All loose, shelly or disintegrated rock was removed and pedestal piles placed on hard, solid, undisturbed rock. If soft rock or shale was encountered the pedestal piles were carried at least 18" into and cast against vertical faces of same. In no case were the pedestal piles placed higher than elevations shown. The Maximum Ultimate Presumptive Bearing Values of 10 Tons per sq. ft. for firm or hard shale and 30 Tons per sq. ft. for firm or unweathered limestone was used in design of pedestal piles.

FINAL PLANS

QUANTITIES table with columns: ITEM, UNIT, SUB-STRUCTURE, SUPER-STRUCTURE, TOTAL. Includes items like Class I Excavation for Structures, 42" Pedestal Pile, Steel Piles in Place, Class B Concrete (Substructure), Class B1 Concrete, Reinforcing Steel, Fabricated Structural Carbon Steel, Bridge Rail, Conduit System, Repair Columns, Conduit System for Kansas City Power and Light Company, 15% Added Cement, Foundation Test holes.

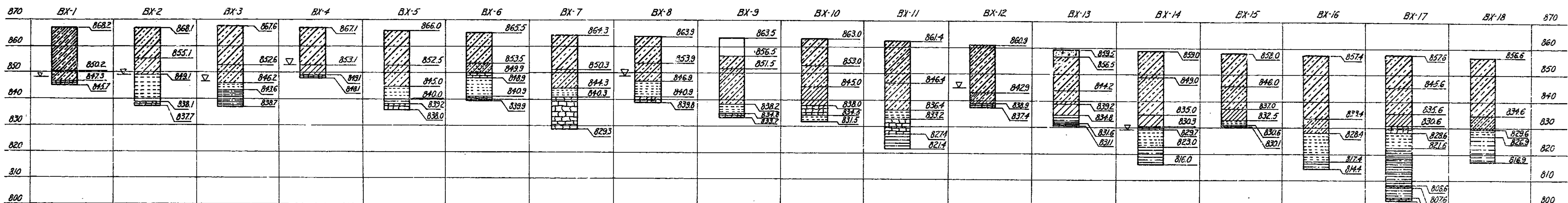

BORING LOG

Quantity Notes:

Estimated quantity of Class B concrete structure includes all concrete in end bents. All other concrete, except in pedestal piles, is included in estimated quantity of Class B1 concrete superstructure. All excavation for bridge was paid for as Class I Excavation for Structures. Sketches show limits of excavation for pay purposes. All concrete and reinforcement above top of pedestal piles at intermediate bents is included in superstructure quantities. Reinforcement in pedestal piles is included in substructure quantities. Weight of bearings is included in weight of fabricated structural carbon steel. No payment was made for excavation below tops of pedestal piles at intermediate bents.

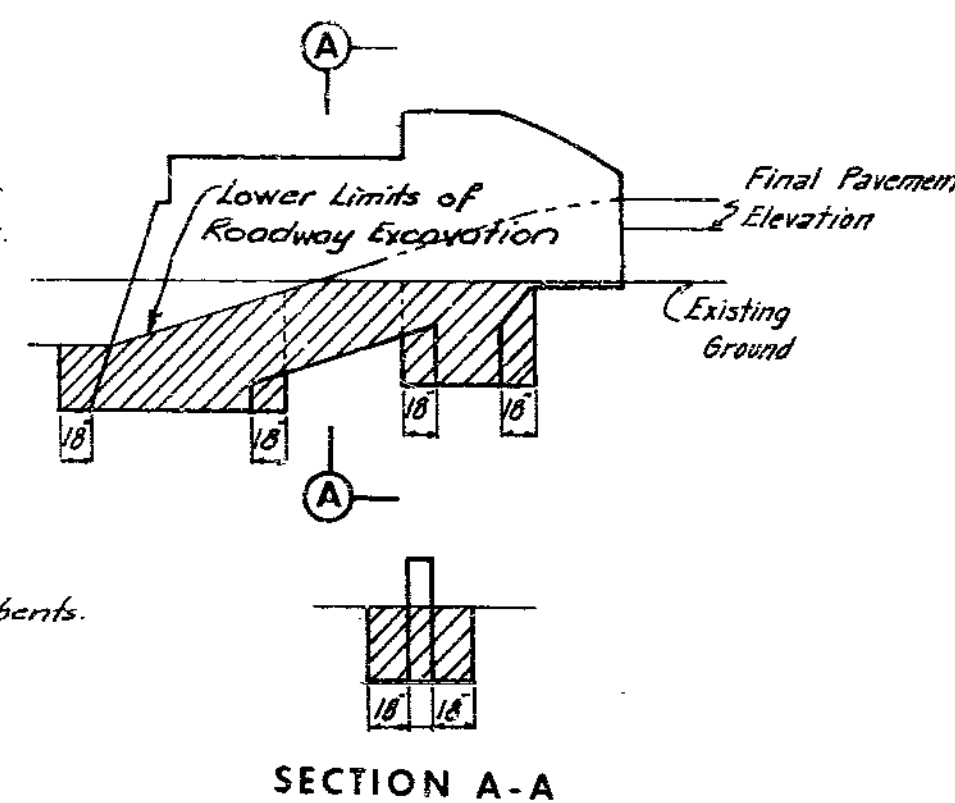

SECTION A-A

BORING LEGEND table with symbols for Fill, Concrete, Silty Loam, Silty Clay, Weathered Limestone, Westerville Limestone, Clay, Shale, and Weathered Shale.

BORING LEGEND

NOTES:

Top elevation of boring is existing ground surface. All borings are augered, except BX-6, BX-7, BX-11 and BX-18 which are cored. Bottom elevations of BX-11, BX-14, BX-16 and BX-18 are in shale. Bottom elevations of BX-6 and BX-7 are in limestone. All other bottom elevations are top of limestone refusal. For location of borings see sheet 1. ▽ designates water level.

FINISHED

BRIDGE: CHARLOTTE STREET UNDERPASS, CROSSTOWN FREEWAY, KANSAS CITY, MO. PROJECT NO. I-70-1(4) (RT. I-70) STA. 47+99.11 @ LANE A, JACKSON COUNTY

GENERAL NOTES

SHEET 2A of 3

A-507

FINAL PLANS

HOWARD, NEEDLES, TAMMEN & BERGENDOFF CONSULTING ENGINEERS, KANSAS CITY, MO.

MADE RYS DATE 11-16-60 TRACED DATE CHECKED JAB/EJLW DATE 11-25-60 SCALE

NOTE: This drawing is not to scale. Follow dimensions.

268

MISSOURI STATE HIGHWAY DEPARTMENT

FED. ROAD DIST. NO.	STATE	FEDERAL PROJECT NO. & SEC.	FISCAL YEAR	SHEET NO.	TOTAL SHEETS
5	MO.	I-70-1(41)2		42	
DIST. NO.	COUNTY	ROUTE & SEC.			
4	JACKSON	I-70			

FINAL PLANS

Cols.	A Bars	B Bars	C Bars	D Bars	E Bars	F Bars	G Bars	H Elev.	I Elev.	J Elev.	K Elev.
2E		11-F421	1-C421	8-C1121	24-C1122	24-F1121		837.7	852.00	869.49	873.99
2W								832.3	850.00	869.89	874.39
7E	30-F471	4-F472	1-C471	8-C1171	20-C1172	20-F1171	8-F1172	811.7	844.75	863.65	868.15
7W	29-F471	4-F472	1-C472	8-C1171	20-C1173	20-F1171	8-F1173	811.0	844.00	863.65	868.15
8E	26-F481	4-F482	1-C481	8-C1181	24-C1182	24-F1181	8-F1182	807.5	842.00	858.65	863.16
8W	26-F481	4-F482	1-C482	8-C1181	24-C1183	24-F1181	8-F1183	813.1	841.50	858.79	863.30
3E		10-F431	1-C431		24-C1131	24-F1131		833.0	847.50	871.58	876.08
3W		7-F431	1-C432		24-C1132	24-F1132		834.6	847.75	871.88	876.38
4E		9-F441	1-C441		8-C1141	8-F1141		835.0	842.75	872.49	876.99
4W		8-F441	1-C442		8-C1142	8-F1142		834.0	841.75	872.48	876.98
5E		18-F451	1-C451		8-C1151	8-F1151		813.6	852.25	871.73	876.23
5W		18-F451	1-C451		8-C1152	8-F1151		813.2	850.25	871.40	875.90
6E		16-F461	1-C461		16-C1161	16-F1161		833.5	847.75	868.78	873.28
6W		15-F461	1-C462		16-C1162	16-F1162		833.7	846.75	868.47	872.97

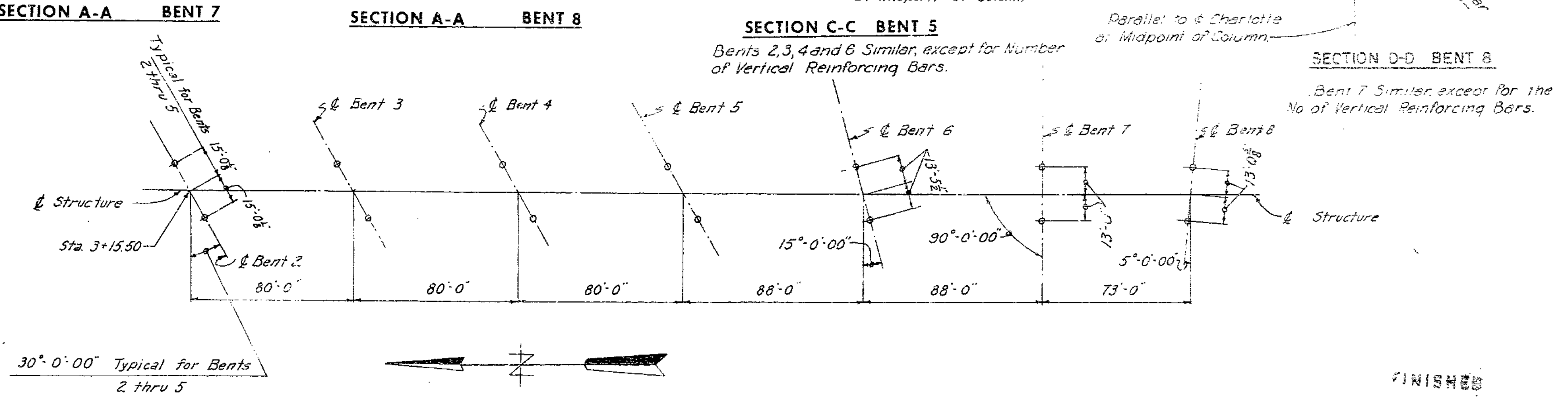
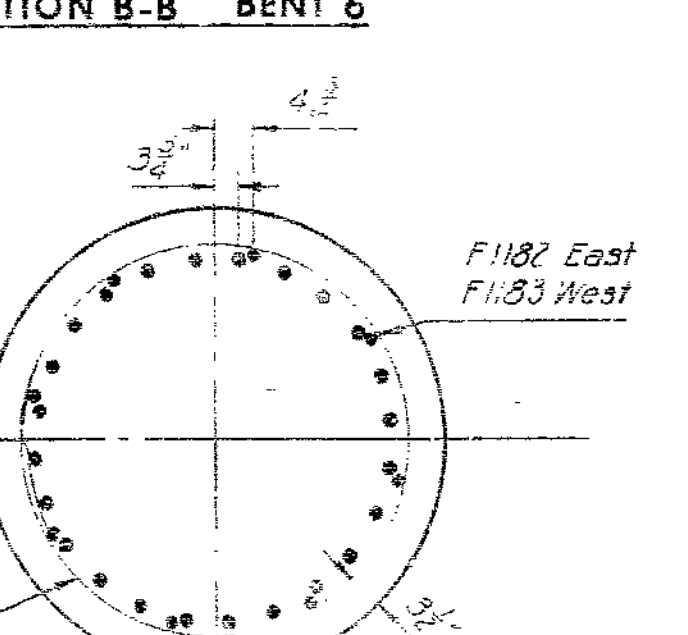
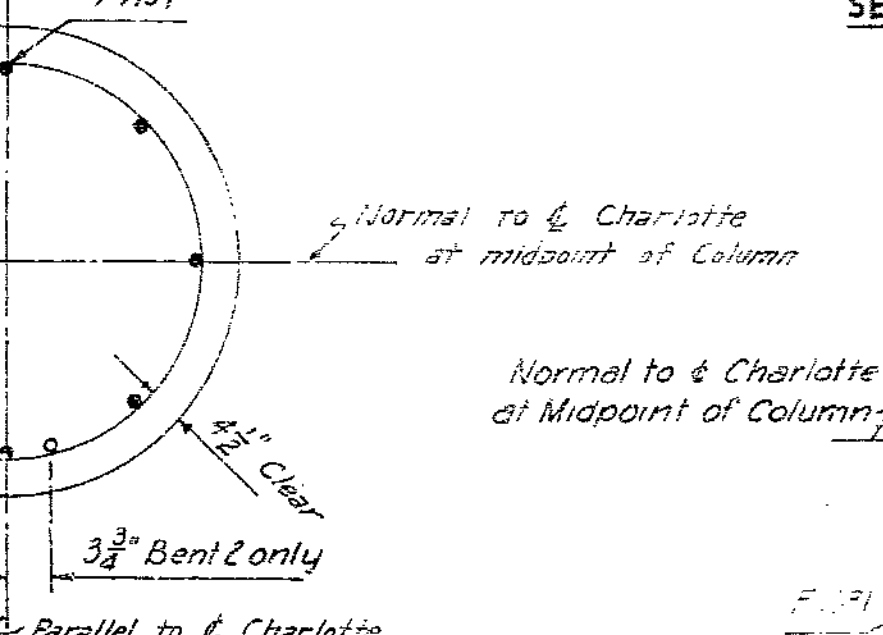
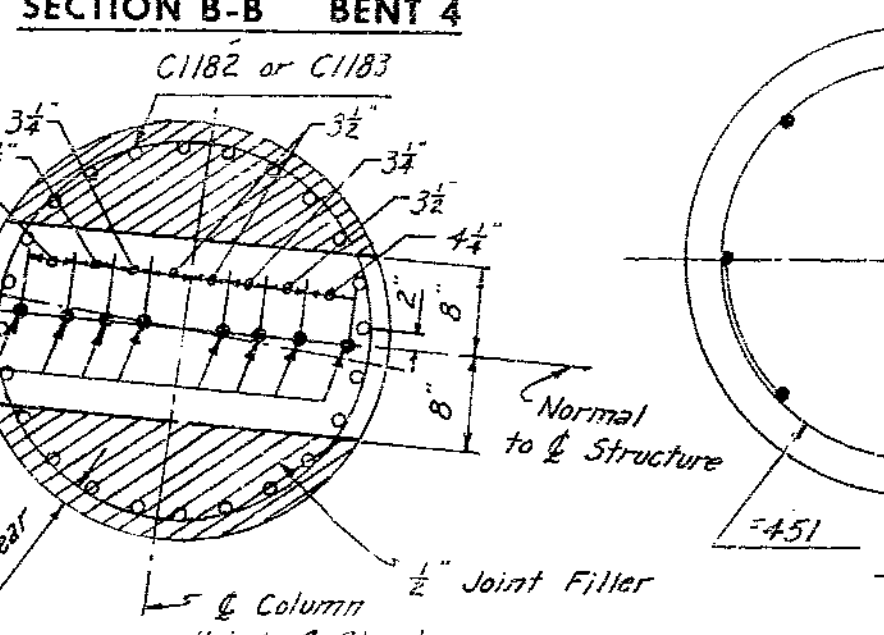
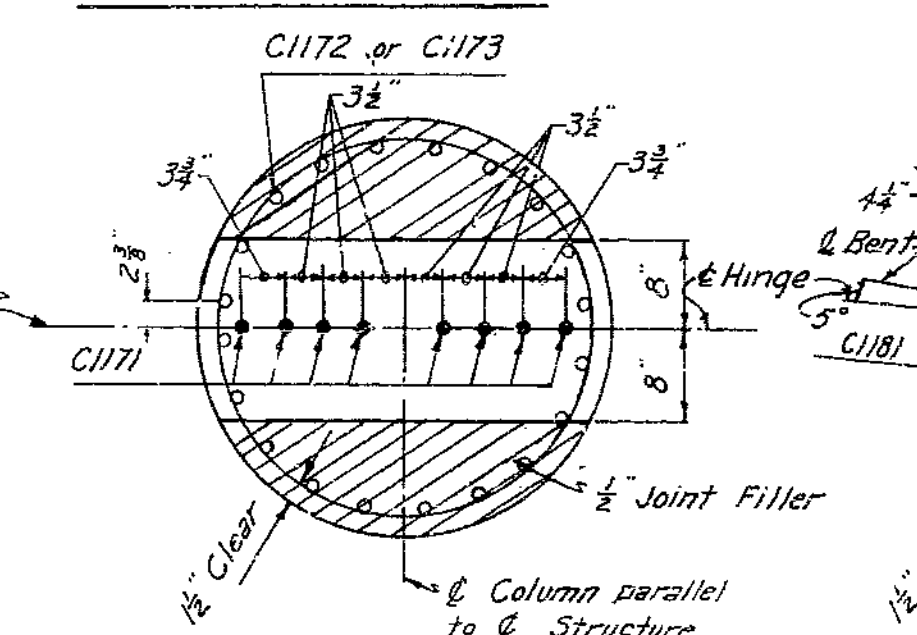
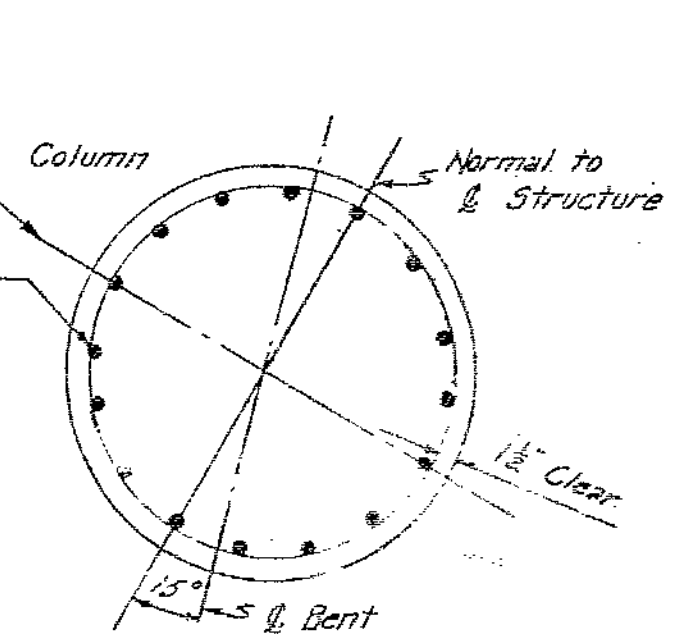
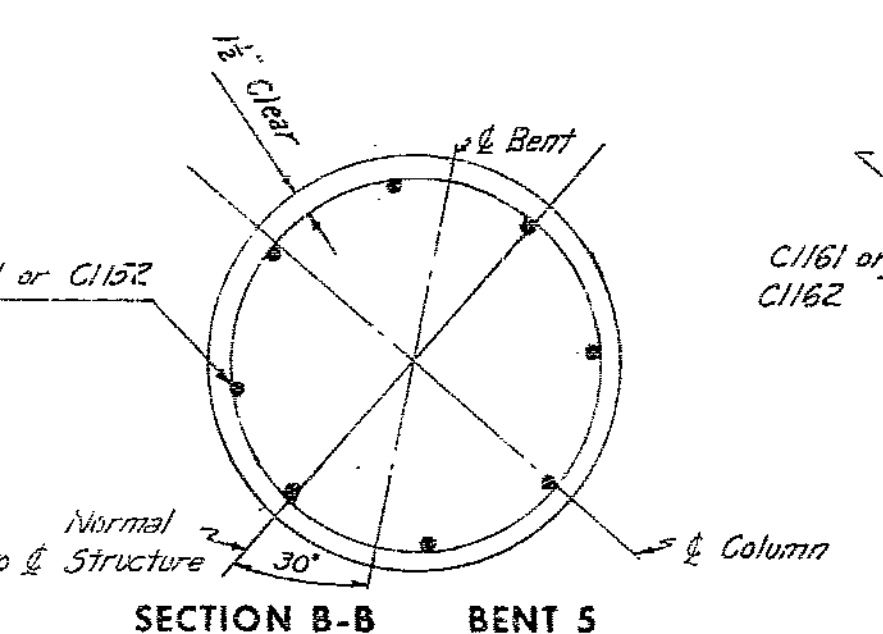
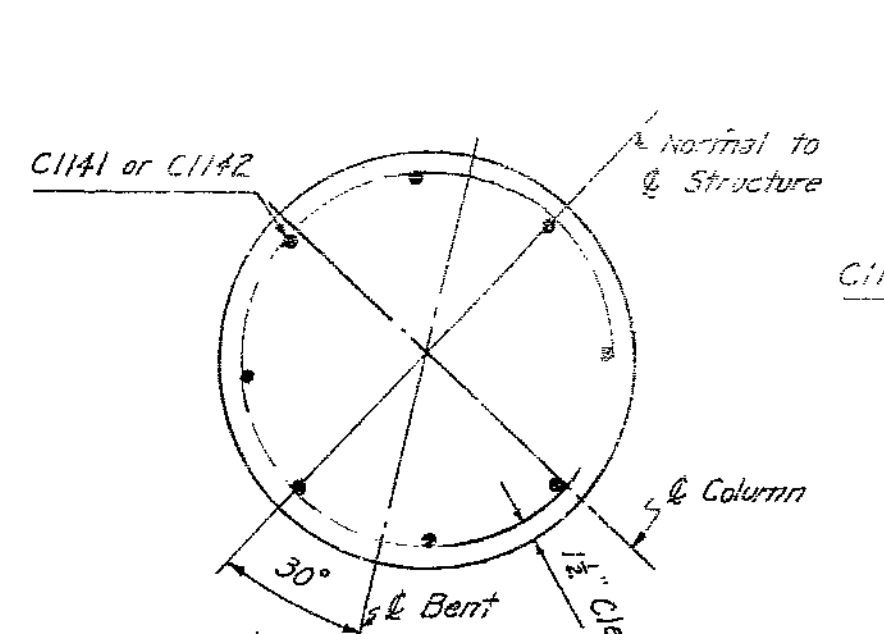
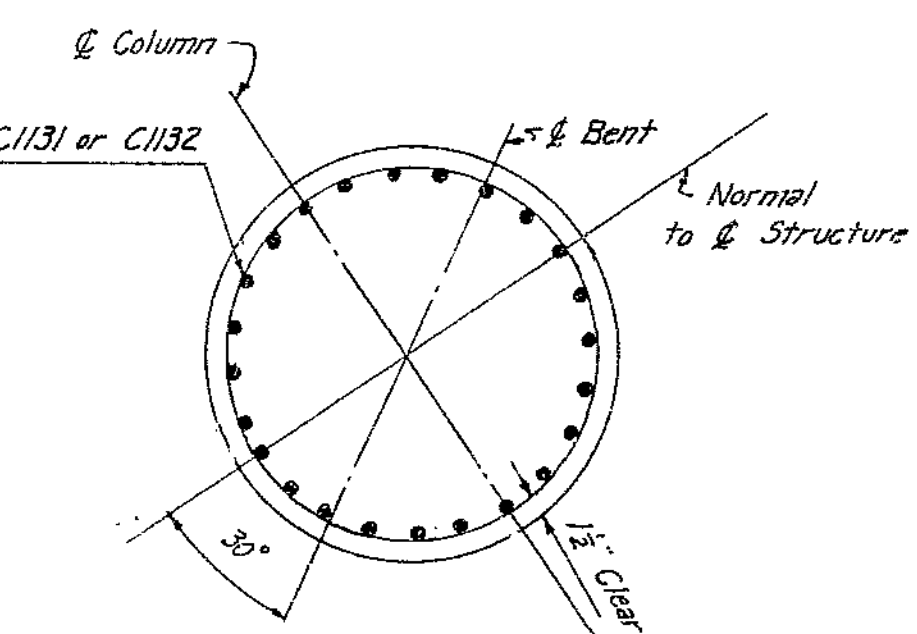
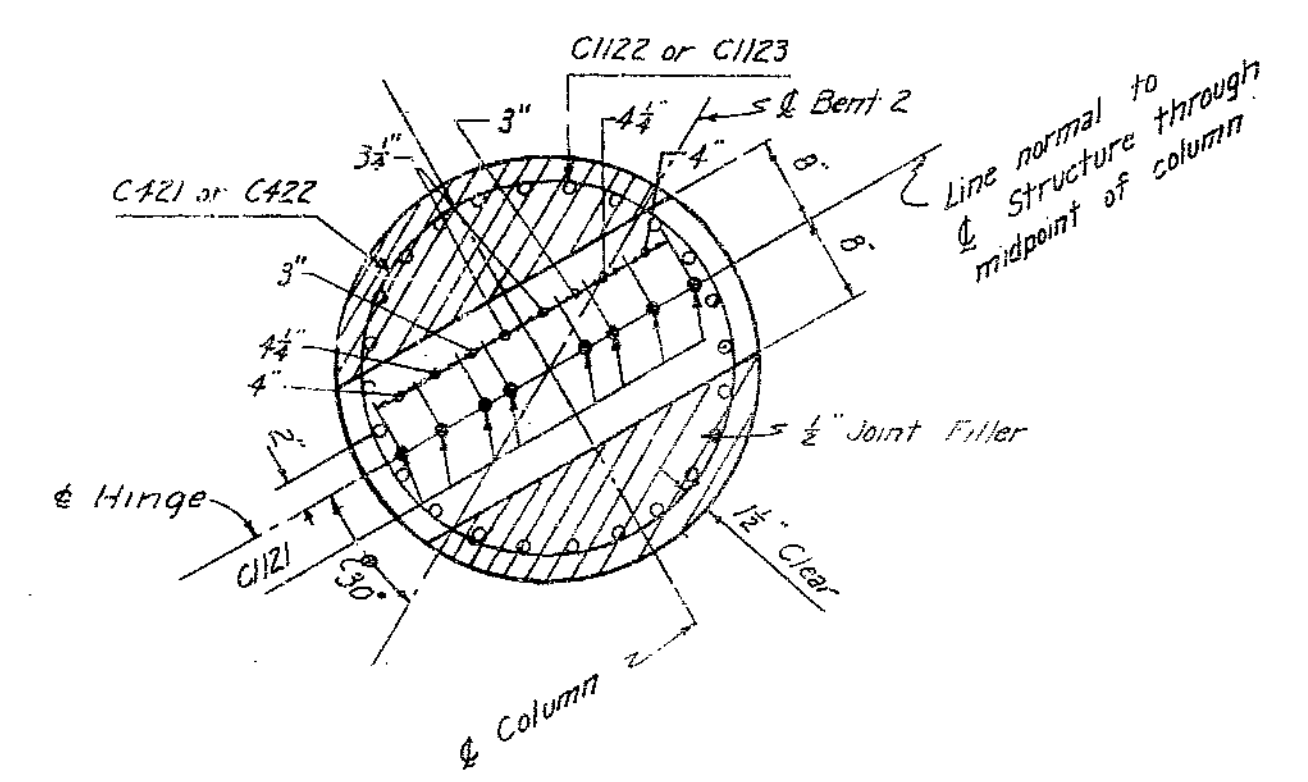
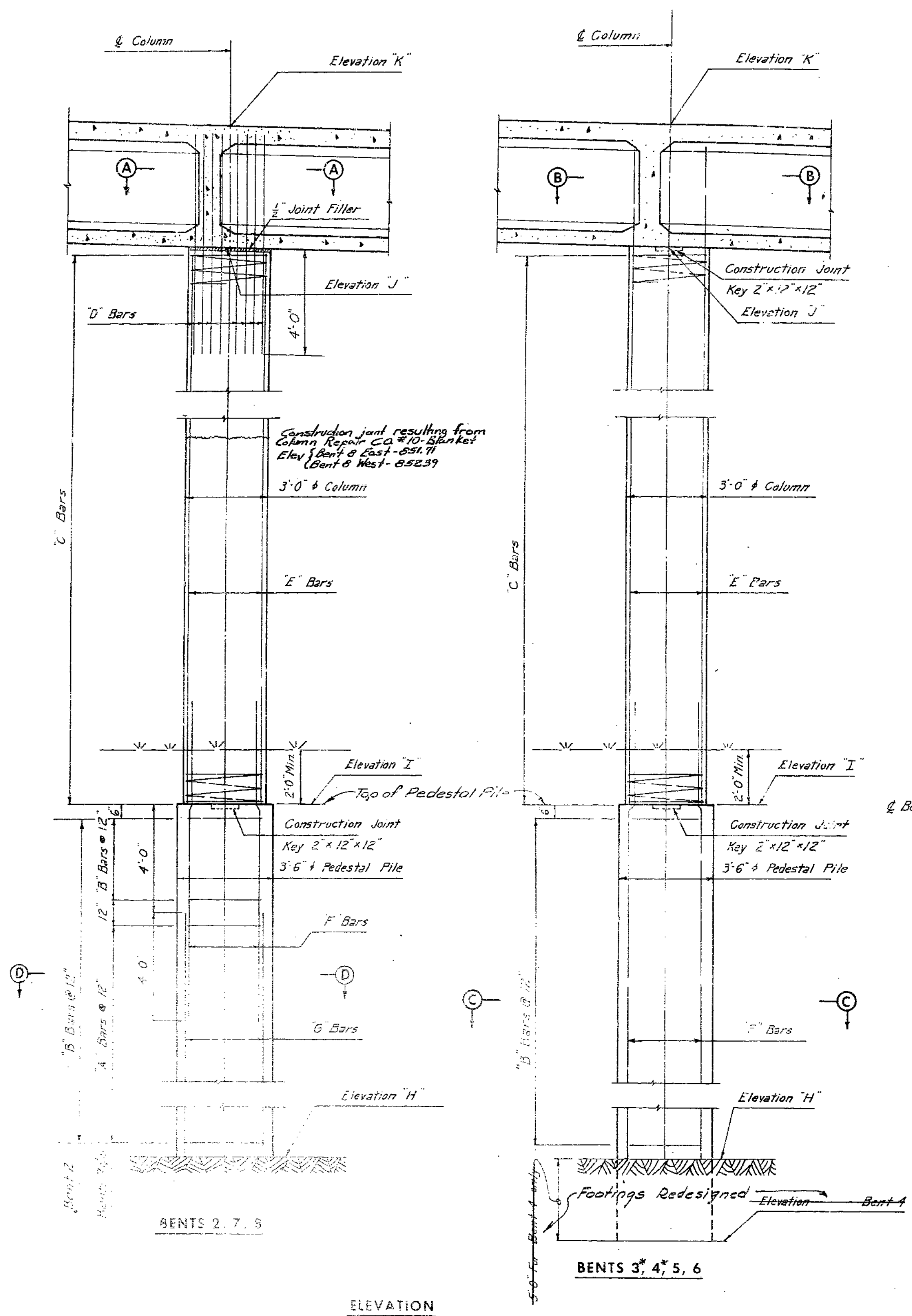

269

HOWARD, NEEDLES, TAMMEN & BERGENDOFF
CONSULTING ENGINEERS
KANSAS CITY NEW YORK

MADE RVS DATE 10-27-60 TRACED DATE
CHECKED JPS DATE 11-22-60 SCALE

NOTE: This drawing is not to scale. Follow dimensions.
*BELL (3W & 4E)

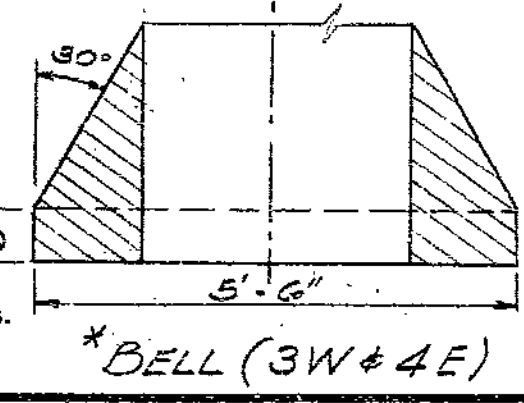

BRIDGE: CHARLOTTE STREET UNDERPASS
CROSSTOWN FREEWAY
KANSAS CITY, MO.
PROJECT NO. I-70-1 (41) (RT. I-70) STA. 47+99.11 @ LANE A
JACKSON COUNTY
SHEET 6A of 3 A-807

FINAL PLANS

MISSOURI HIGHWAY AND TRANSPORTATION COMMISSION

FED. ROAD DIST. NO.	STATE	FED. AID PROJ. NO.	FISCAL YEAR	SHEET NO.	TOTAL SHEETS
5	MO.		89	22	
SEC./SUR. 5		TWP. 49N RGE. 3W			

ESTIMATED QUANTITIES		
ITEM		TOTAL
Class B2 Concrete	Cu. Yds.	465.9
Safety Barrier Curb	Lin. Ft.	1161
Elastomeric Expansion Joint Seal (2.5 in.)	Lin. Ft.	112
Conduit System on Structure	Lump Sum	1
Post Tension System	Lump Sum	1
Special Work	Lump Sum	1
Shear Keys	Each	153
(12 in.) Pedestrian Fence (Structures)	Lin. Ft.	1200
Cleaning and Painting Bearings	Each	14

Note: Cost of furnishing and installing 5#1, 5-52, 5-53, 5-U11 and 4x4-w4xw4 welded wire fabric (epoxy coated) shall be included in price bid for Class B2 Concrete.

GENERAL NOTES

Design Specifications: A.A.S.H.T.O. & Interims thru 1982
 Design Loading: HS20-44 Modified 24,000⁺ Tandem axle.
 Design Unit Stresses:
 Class B1 Concrete (safety barrier curb) $f_c = 16,000$ psi
 Class B2 Concrete (superstructure except safety barrier curb) $f_c = 20,000$ psi.
 Reinforcing Steel (Grade 60) $f_s = 24,000$ psi.

Joint Filler:
 All joint filler shall meet the requirement of Std. Spec. 1057.2.4 except as noted.

Reinforcing Steel:
 Minimum clearance to reinforcing steel shall be $1\frac{1}{2}$ " unless otherwise shown.
 Adequate reinforcing other than the specified welded wire fabric may be used with the approval of the engineer.
 Bars bonded in old concrete not removed shall be cleanly stripped and embedded into new concrete where possible (does not apply to slab steel). If length is available old bars shall extend into new concrete at least 40 diameters for smooth bars and 30 diameters for deformed bars.
 Contractor shall verify all dimensions in field before ordering new material.

Post Tensioning:
 Post tensioning strands shall be $\frac{1}{2}$ " diameter epoxy coated seven-wire low relaxation strands with an initial post tension force of 30.95 kips, conforming to AASHTO M203, Grade 270.
 The method and sequence of stressing the strands shall be shown on the shop drawings. Suitable strand anchorage devices shall be cast in overlay and shall be shown on shop drawings and approved by the engineer.
 Details shown on these plans are not indicative of any particular type of Post Tension Anchorage System.
 PVC duct friction factors were computed for $\mu = 0.08$ $K = 0.0014$. Anchor set for all strands was computed at $\frac{1}{4}$ " and for transverse bars was computed at 0".
 Threaded bars shall be $\frac{3}{8}$ " nominal diameter epoxy coated with an initial post tension force of 31.50 kips, and conforming to AASHTO M275, Type I or Type II.
 In no case shall the working stress in the concrete due to post tensioning after anchorage and all losses provide less compressive stress than 140 psi.

Construction Clearance:
 Falsework over exist. Lane A and Lane B shall be constructed with a minimum vertical clearance of 14'6" from crown of exist. lanes and a minimum lateral clearance of 4'0" centered on exist. lanes.
 Falsework over exist. Lane K and Lane J shall be constructed with a minimum vertical clearance of 14'6" from crown of exist. lanes and a minimum lateral clearance of 2'4" centered on exist. lanes.

Conduit System:
 Shift reinforcement steel in field where necessary to clear conduit and junction boxes.
 The junction boxes shall be PVC molded, flush mounted, size 8"x8"x4". They shall be equal to "Carlton" Electrical Construction Products or "Triangle" Conduit and Cable Co., Inc. The conduit terminations shall be permanent or separable. The terminations and cover shall be watertight construction.
 Conduit shall be schedule 40-Heavy Wall PVC (Polyvinyl Chloride) plastic or HDP (High Density Polyethylene) with 3" minimum cover in concrete.
 Expansion Couplings shall provide a minimum movement in either direction of $2\frac{1}{2}$ " at open joints at Bents No. 1 & 9 and a minimum movement in either direction of $\frac{1}{2}$ " at filled joints.
 All wiring to be furnished and installed by others.
 Top of light standard supports to be made horizontal, anchor bolts to be placed vertically.

The contractor shall pour and satisfactorily finish the slab pours for the sequence as shown on the "Plan of Slab"-sh. no. 2.
 The test system for epoxy coated reinforcing as specified in Sec. 710.3.4 of the Standard Specification will not be required on this bridge.
 Top of backwall and exp. device for end Bts. 1 & 9 to conform to crown of roadway slab. Conc. above top of exist. backwall shall not be poured until the superstructure slab has been poured in the adjacent span.
 Outline of old work is indicated by light dashed lines, heavy lines indicate new work.

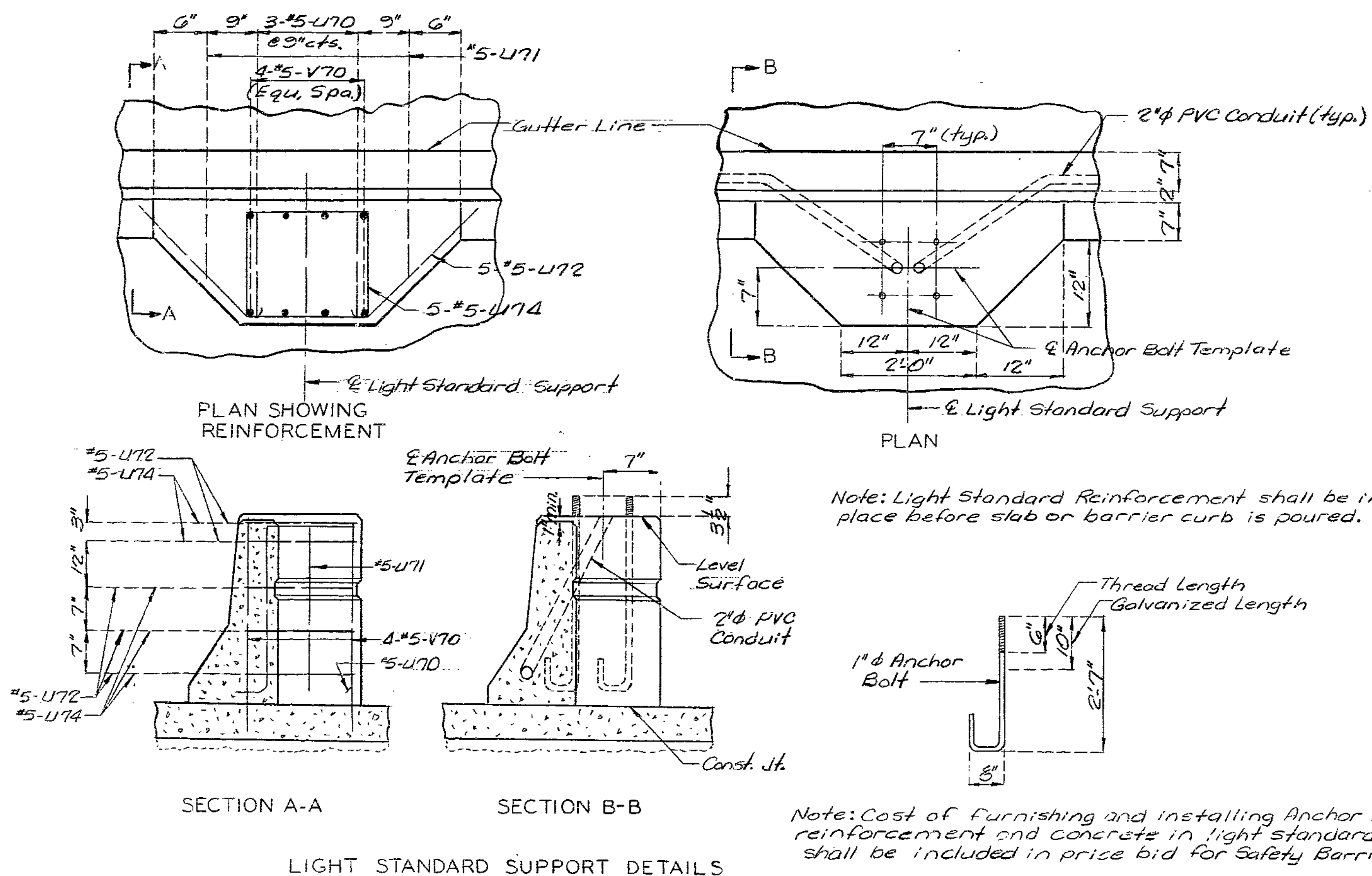

Note: Light Standard Reinforcement shall be in place before slab or barrier curb is poured.

Note: Cost of furnishing and installing Anchor Bolts, reinforcement and concrete in light standard support shall be included in price bid for Safety Barrier Curb.

B.M.

BRIDGE: CHARLOTTE STREET UNDERPASS

STATE ROAD: I-35 & I-70 INTERCHANGE

ABOUT 14 TH & CHARLOTTE

PROJECT NO. IR-35-1(204) STA. 47+99.11 @ LANE A

JOB NO. 4-I035-139B RTE. I-35

JACKSON COUNTY

STD.
STD. 706.35
A-807R

DESIGNED April 1984
 DETAILED May 1984
 CHECKED June 1984

Note: This drawing is not to scale. Follow dimensions.

Sheet No. 1 of 8.

DATE June 29, 1984

FED. ROAD DIST. NO.	STATE	FED. AID PROJ. NO.	FISCAL YEAR	SHEET NO.	TOTAL SHEETS
5	MO.		19	23	

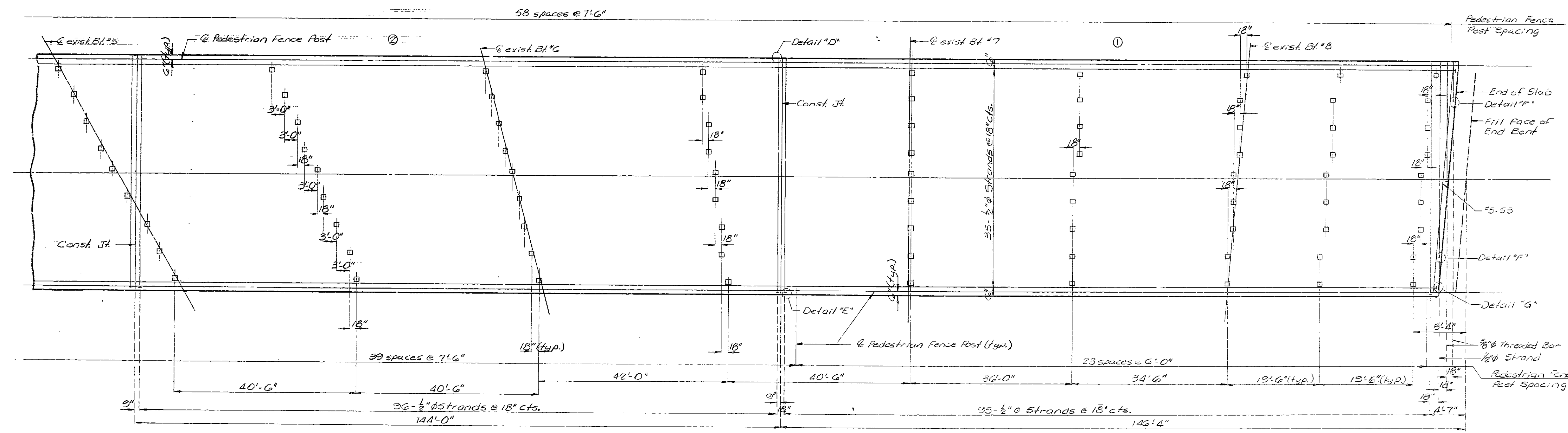
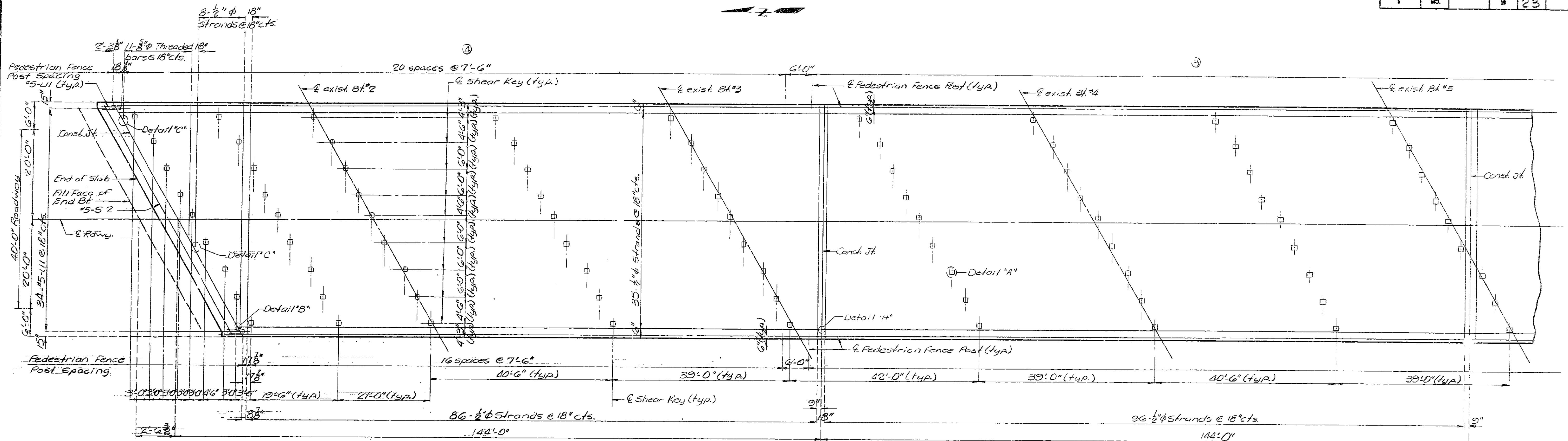

PLAN OF SLAB

355
 DETAILED April 1984
 CHECKED June 1984

Note: This drawing is not to scale. Follow dimensions.

Sheet No. 2 of 8.

JACKSON COUNTY

A-807R

FED. ROAD DIST. NO.	STATE	FED. AID PROJ. NO.	FISCAL YEAR	SHEET NO.	TOTAL SHEETS
5	MO.		18	24	

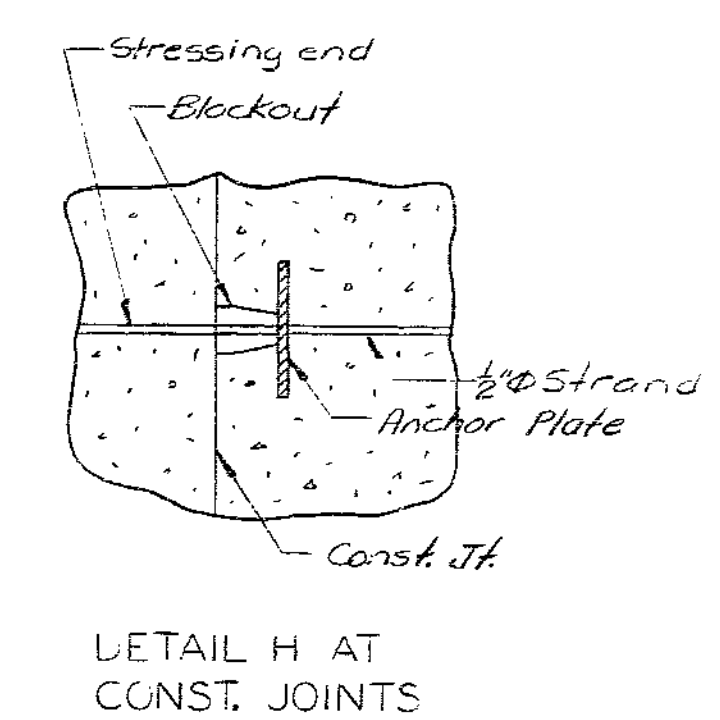
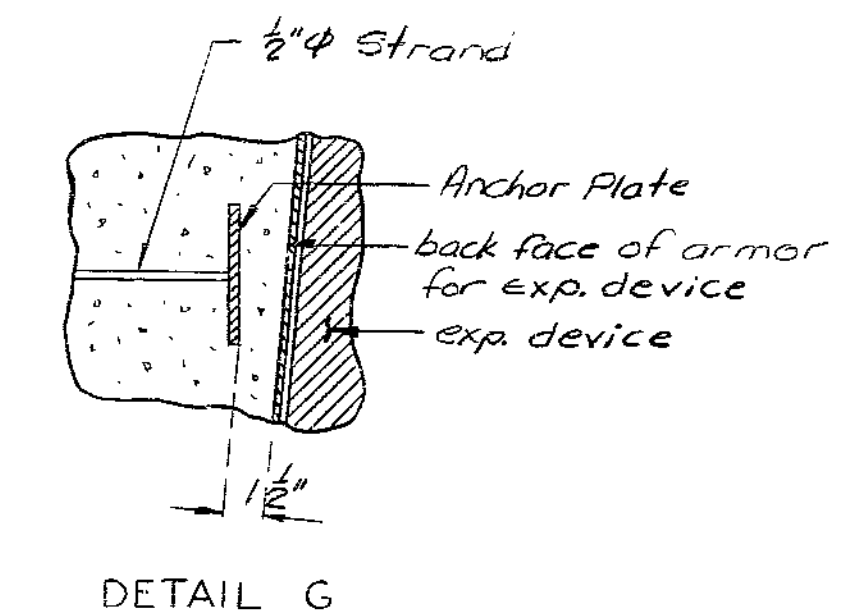
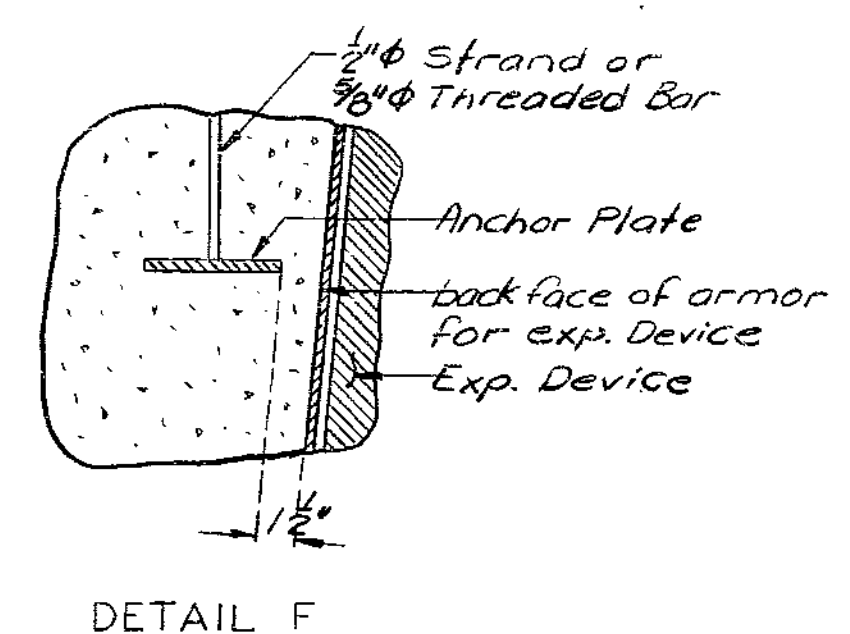
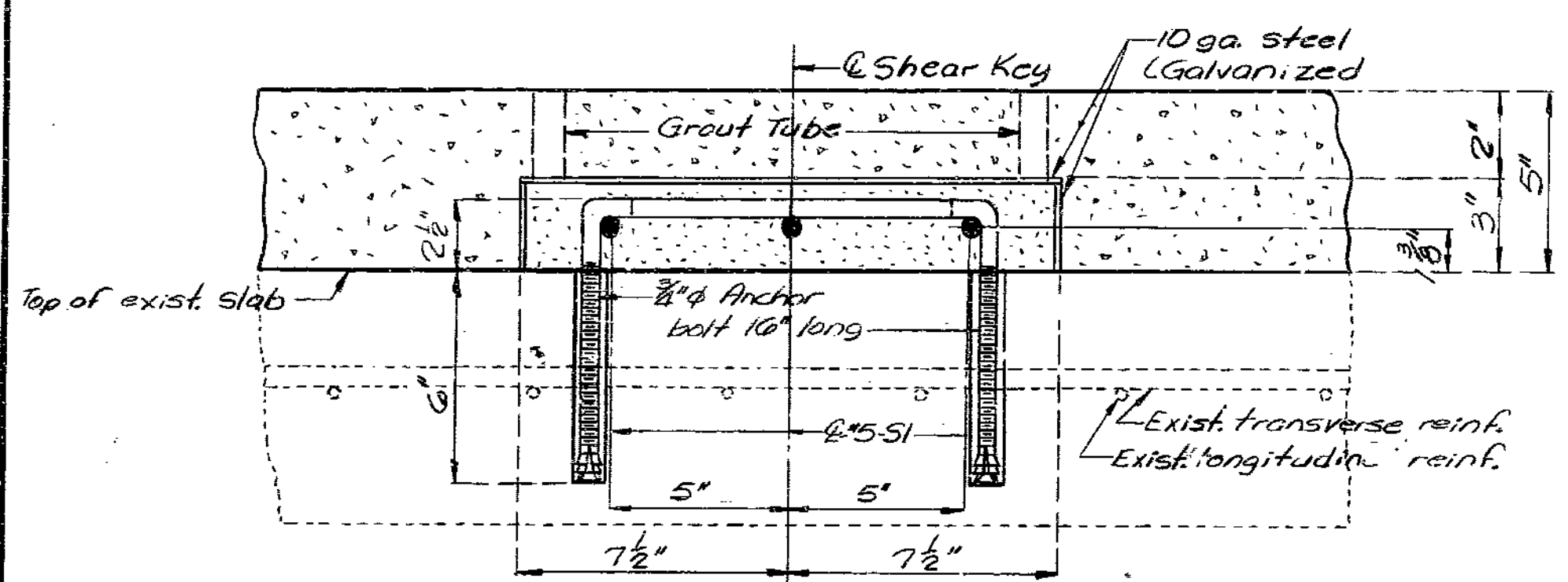
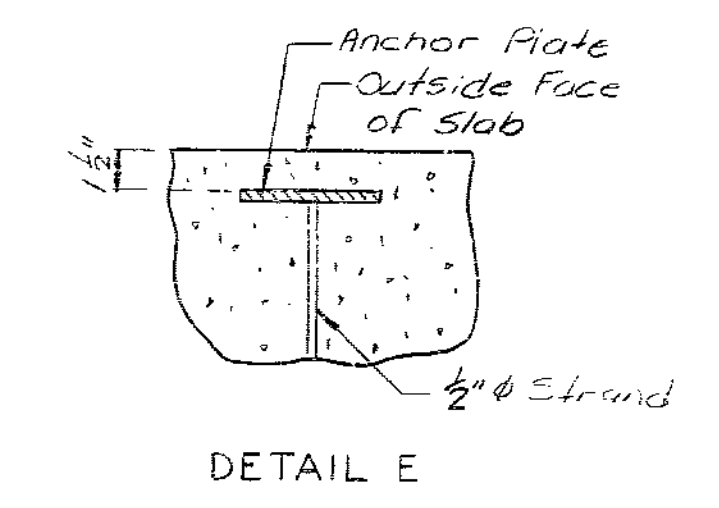
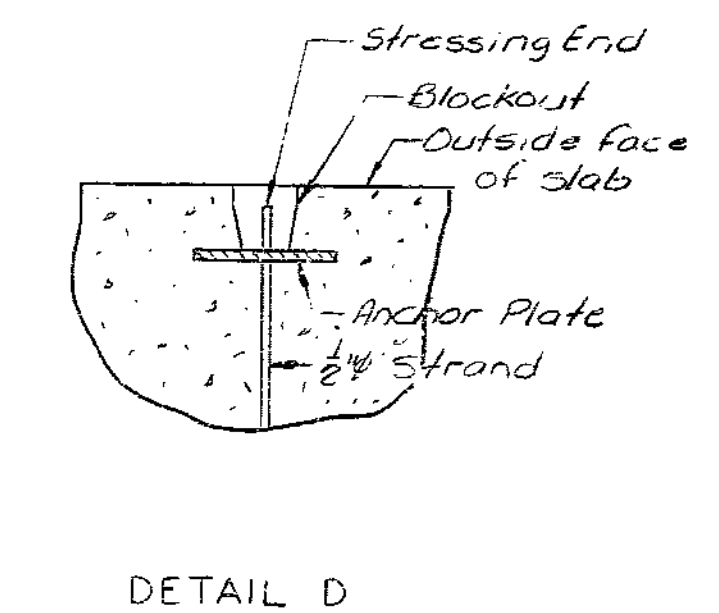
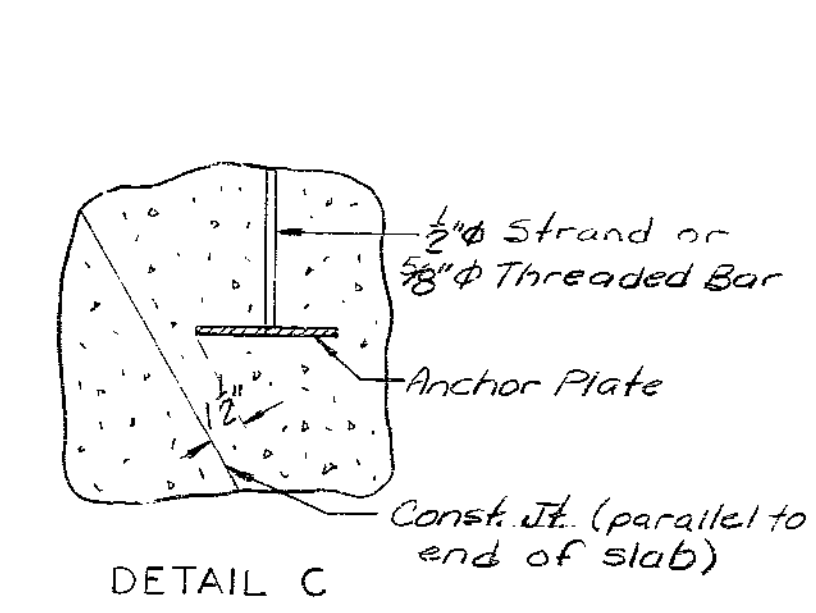
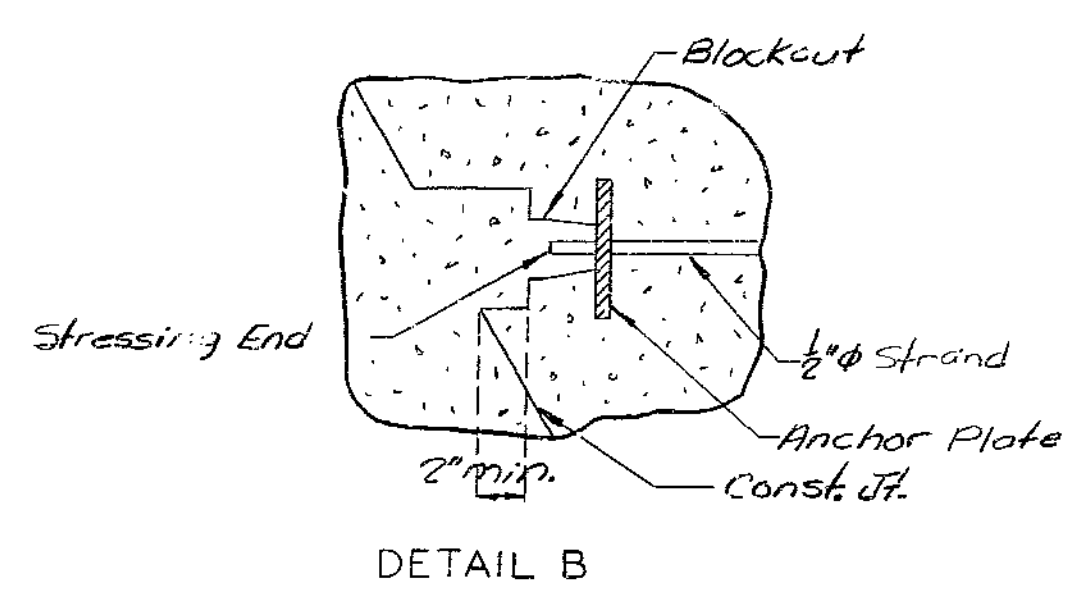
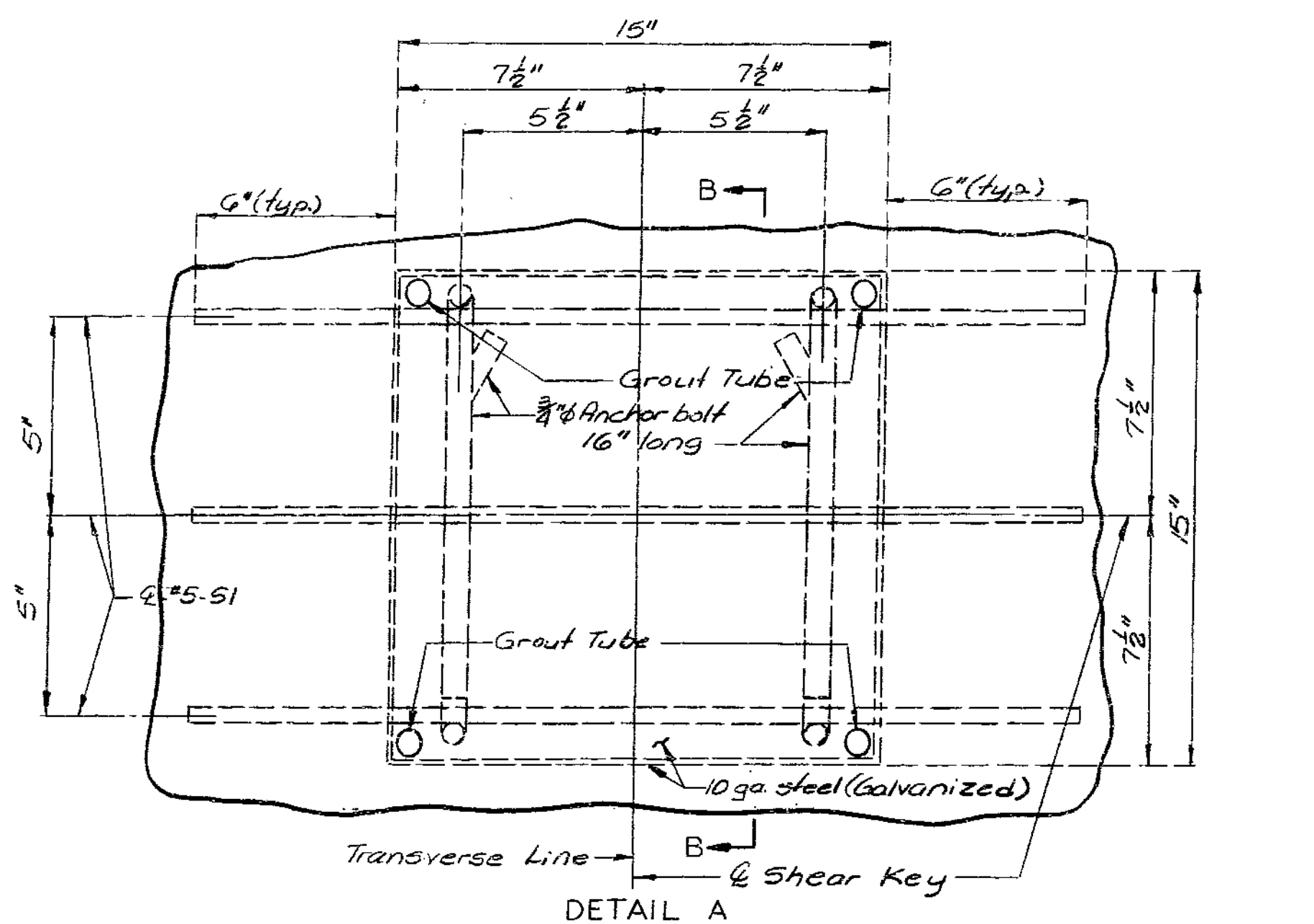

Note: For location of Details "A", "B", "C", "D", "E", "F", "G" and "H", see sheet no. 2.

Note: Concrete anchors shall be the cone expansion type for hot-dip galvanized bolts. Concrete anchors shall have a concrete pull-out strength (ultimate load) of at least 15,500 lbs. in 3,000 psi concrete.
 Cost of furnishing and installing anchor bolt assemblies, #5-S1 bars and keyway pans in shear keys, shall be included in contract unit price for shear keys.
 Pedestrian guard fence (Chain link type) shall be in accordance with Section 1042 of the Std. Spec., except all fabric shall have top and bottom edges knuckled.
 All rail posts shall be vertical. Grout of 1/2" min. thickness shall be placed under floor plates to provide for vertical alignment of rail posts.
 Measurement of pedestrian guard fence shall be taken parallel to grade through the centerline of posts.
 Note: Cost of furnishing and installing bolts, nuts, washers, pipe sleeves, plates, grout and other items necessary to attach pedestrian fence to deck to be included in price bid for (221N) Pedestrian Fence (Structures).

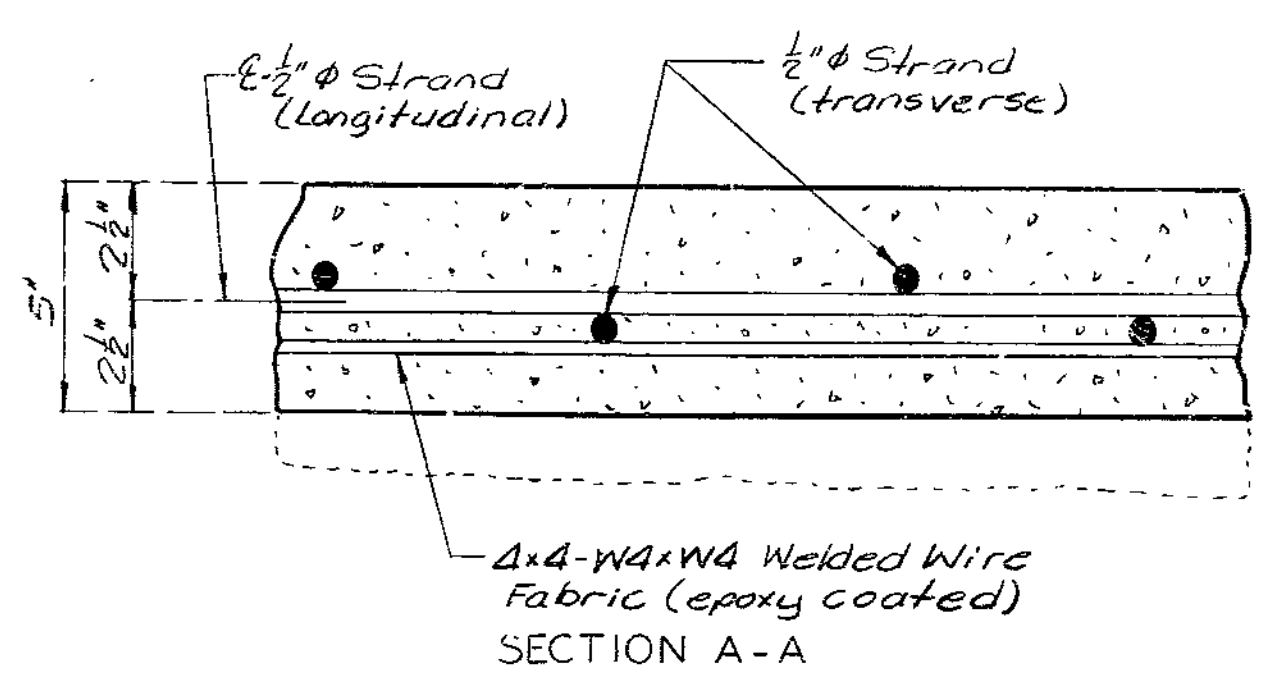
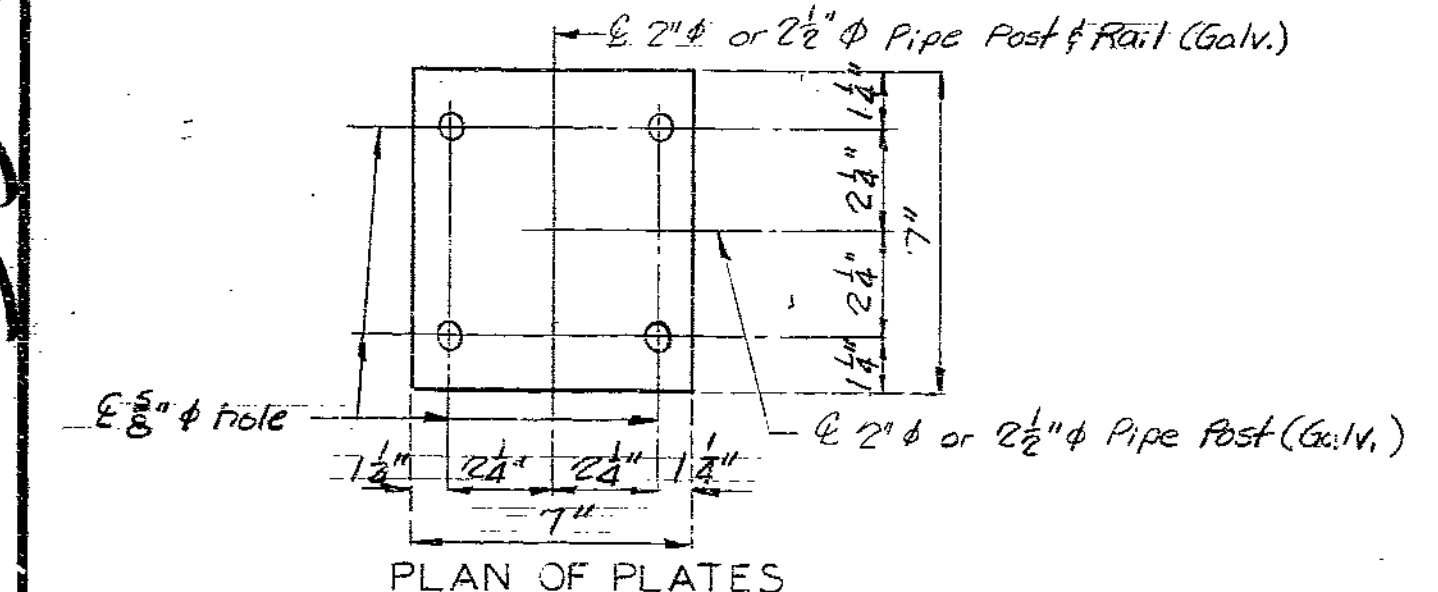
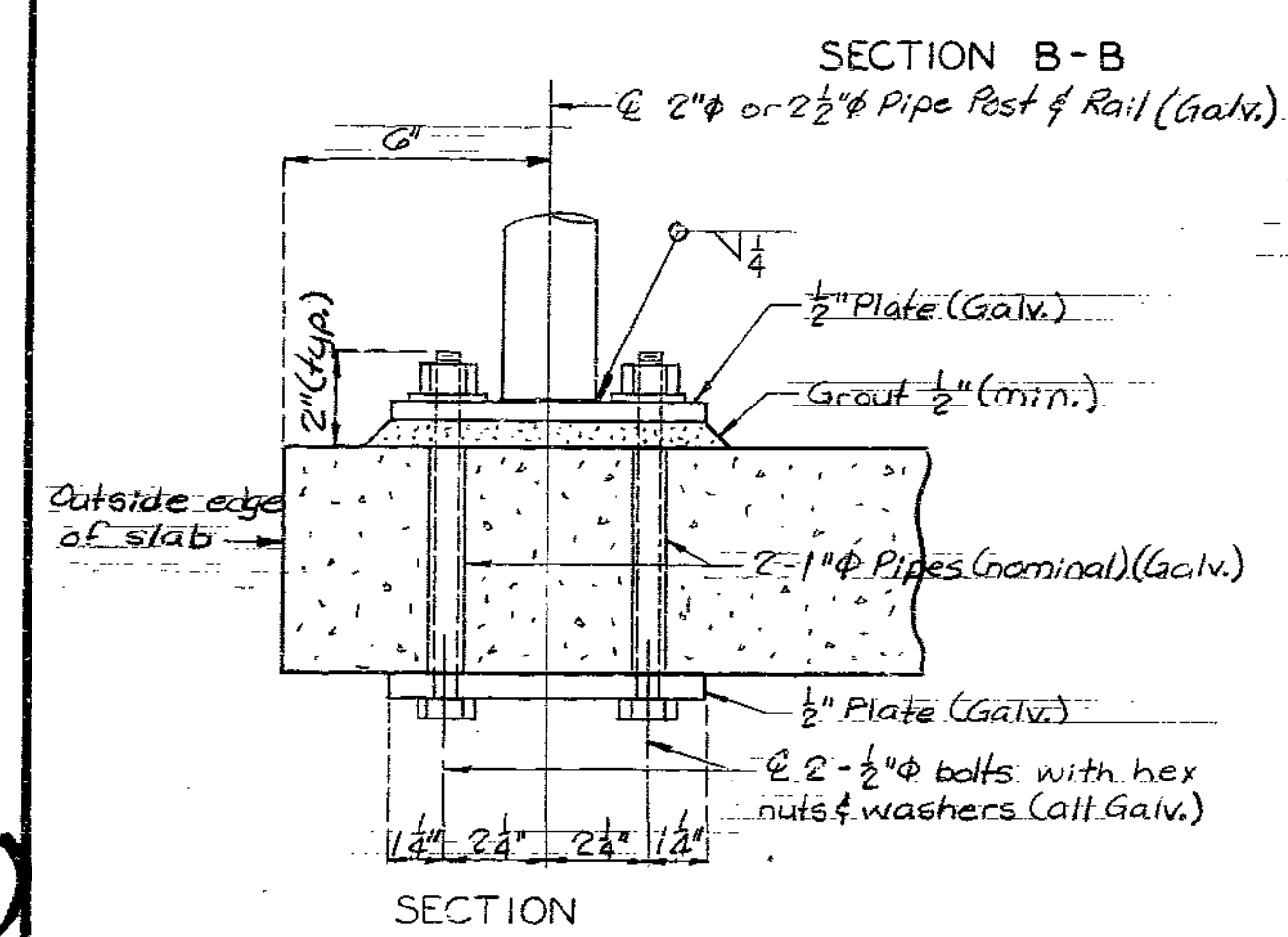

Note: 4x4-W4xW4 Welded Wire Fabric shall extend to vertical face of plate at Exp. Gap and shall be cut to fit around keyway pans.

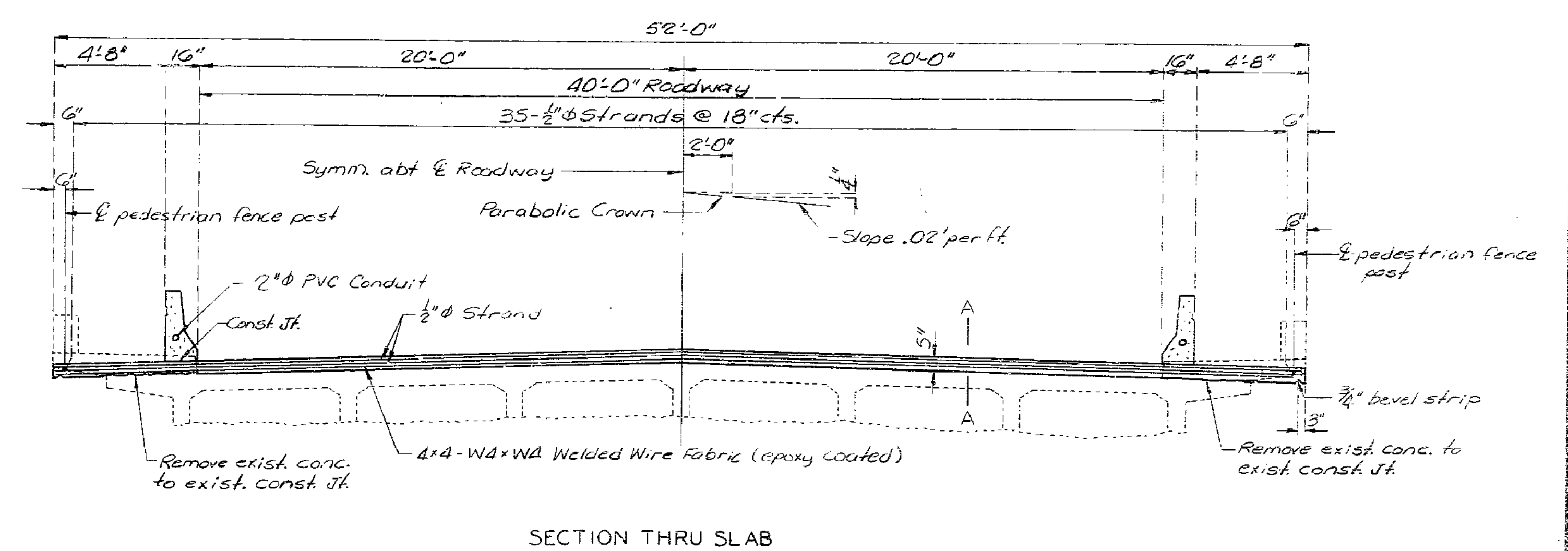

Note: For Details and reinforcement of safety barrier curb, see sheet no. 6.

DETAILS OF RAIL POST CONNECTION
 DETAILED May 1984
 CHECKED June 1984

Note: This drawing is not to scale. Follow dimensions.

Sheet No. 3 of 8.

JACKSON COUNTY

A-807R

356

STATE	PROJ NO	SHEET NO
MO.		25

* Limits of exist. sidewalk to be removed to plane at top of exist. slab.
 ** Limits of exist. parapet and wingwall to be removed to plane at top of exist. slab.

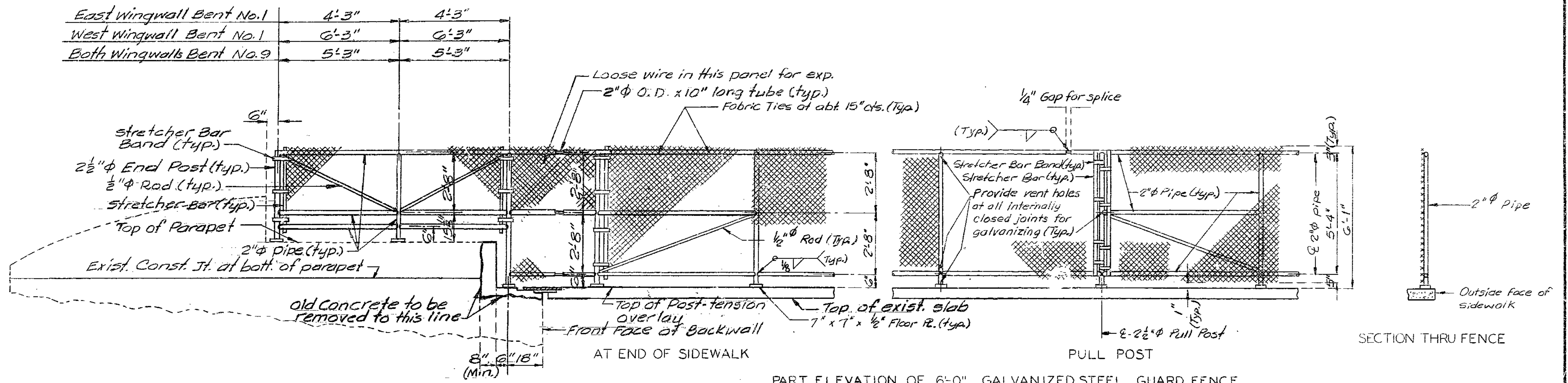

Note: Payment for furnishing and installing 2" φ concrete anchor bolts for rail post attachment to end bents shall be included in Contract unit price for Pedestrian Fence. 1/2" φ concrete anchor bolts shall be cone expansion type and shall have a pull out strength (ultimate load) of at least 7,400 lbs. in 3,000 psi concrete. At the option of the contractor one of the following anchor systems may be substituted for the cone expansion type: 1. Hilti HVA Adhesive Anchors 2. Molly Parapond Capsule Anchors 3. U.S.E. Diamond Capsule Anchors. These optional anchor systems shall be installed according to the manufactures specifications. For Pedestrian Fence Post spacing on bridge deck, see Plan of slab.

Note: Pull Post shall be used approximately 100' centers.

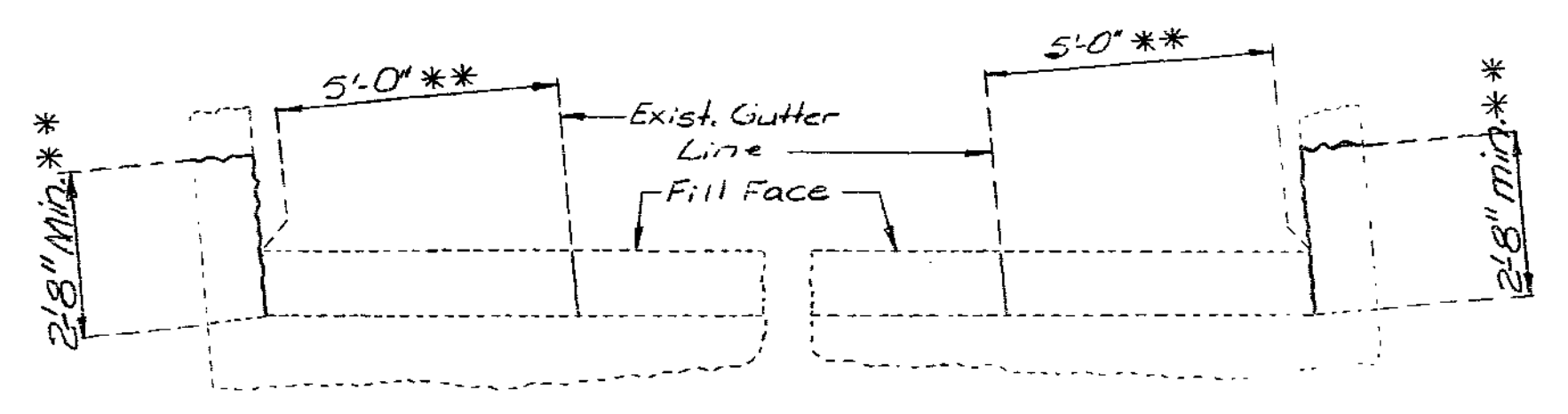

PART PLAN SHOWING CONCRETE REMOVAL

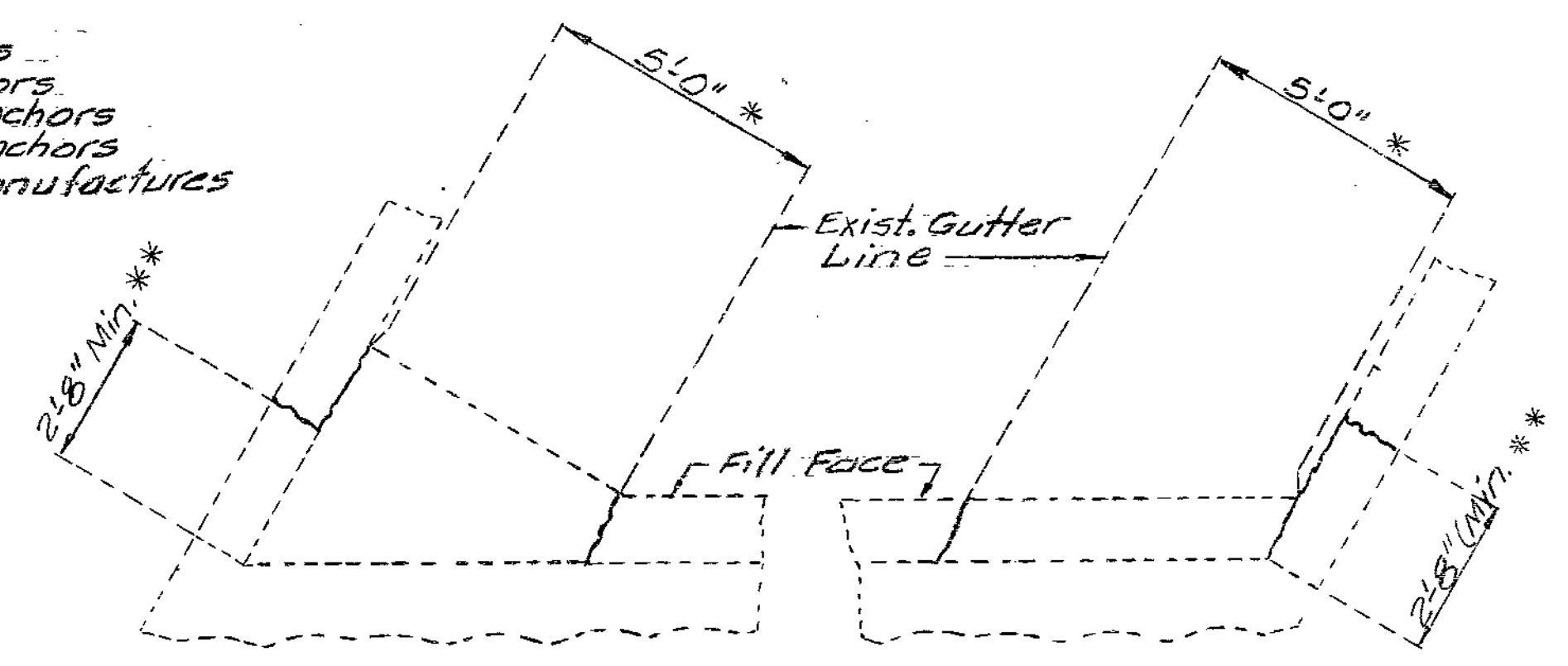

PART PLAN SHOWING CONCRETE REMOVAL

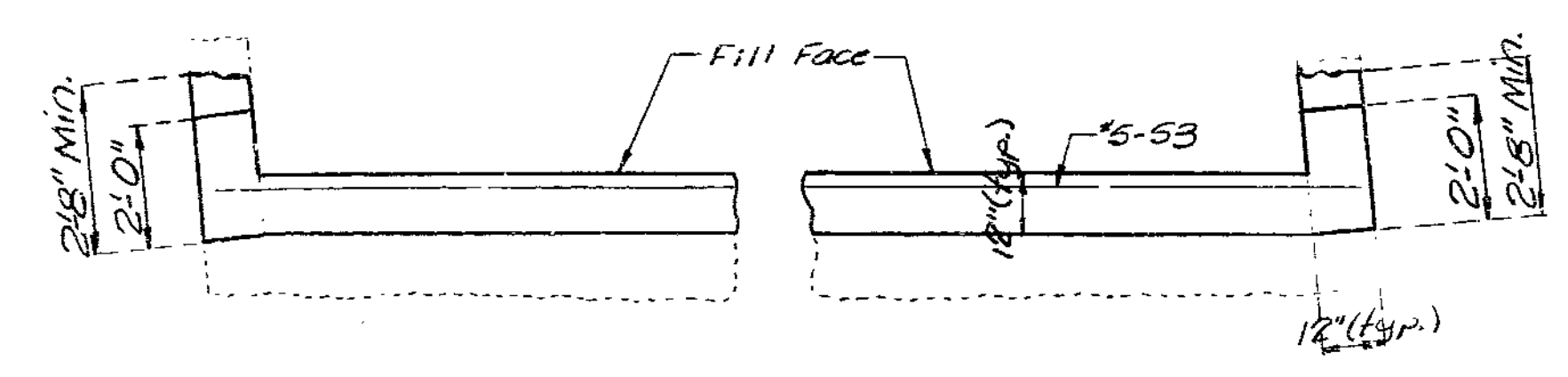

PART PLAN DETAILS OF END BENT NO 9

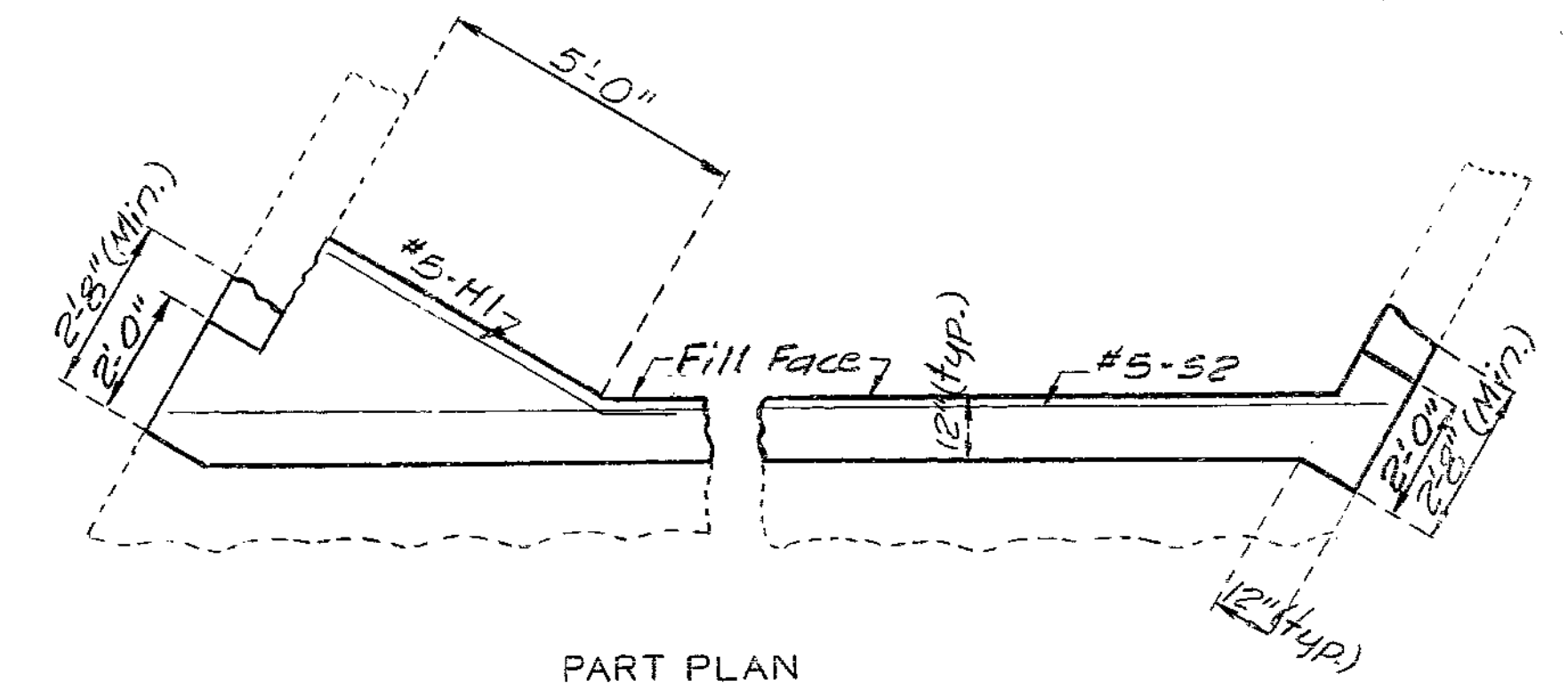

PART PLAN DETAILS OF END BENT NO. 1

357

Note: This drawing is not to scale. Follow dimensions.

DETAILED June 1984
 CHECKED June 1984

Sheet No. 4 of 8

JACKSON COUNTY

A-807R

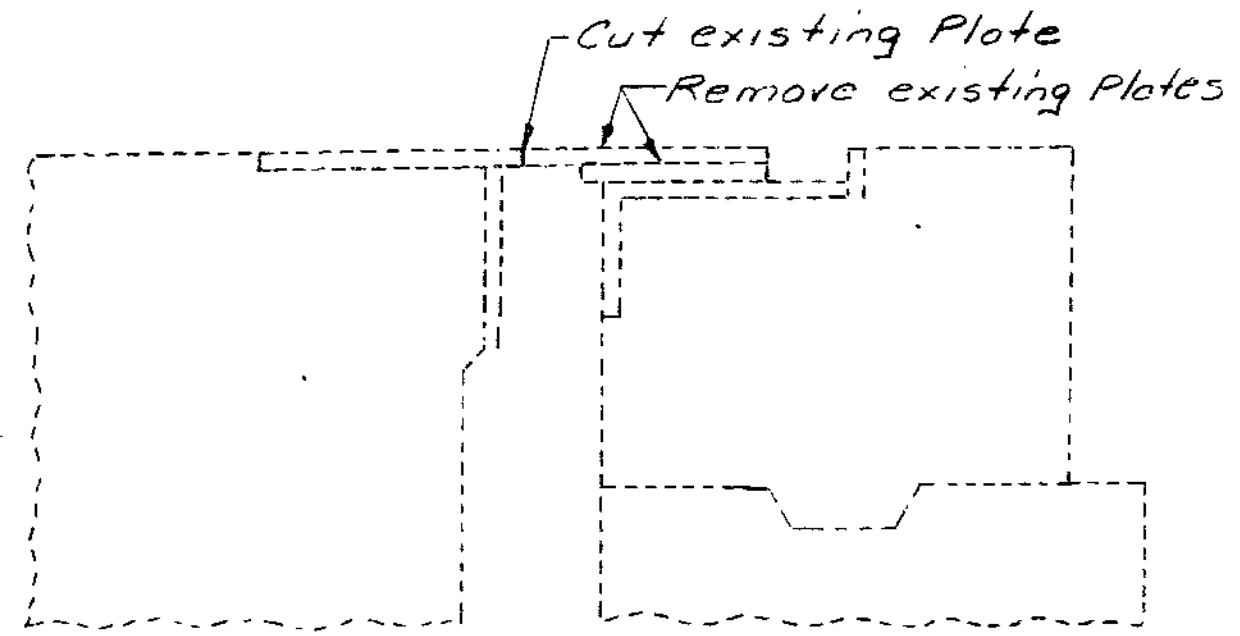

PART SECTION THRU EXISTING EXPANSION DEVICE

LOCATION	ACCEPTABLE ALTERNATE TYPES	EXP. GAP AT 60°	TABLE OF DIMENSIONS						ANCHOR STUDS SIZE	"G"
			"A" AT 60°	"B"	"C"	"D"	"E"	"F"		
Bts. No. 1 & 9	Acme Trojan TR300	2"	11 1/2"	4 1/4"	1 3/8"	1 7/8"	1 3/4"	2 1/4"	1/2"	40
	Gen-Strip CCL 2 1/2"	2 1/2"	11 1/2"	4"	1 3/8"	1 7/8"	1 3/4"	2 1/4"	3/8"	65
	Wabo BendoFlex 250	2"	11 1/2"	4 1/4"	1 3/8"	1 7/8"	1 3/4"	2 1/4"	1/2"	50
	Fel-Span T30 CS	1 3/4"	11 3/8"	4 1/2"	1 3/8"	1 7/8"	1 3/4"	2 1/2"	1/2"	50
	On-Flex 25	1 1/2"	11"	4 1/4"	1 3/8"	1 7/8"	1 3/4"	2 1/8"	1/2"	65
Delastiflex-LM300	2"	12 3/8"	4 1/8"	2 3/16"	1"	2"	2 1/2"	1/2"	45	

NOTE: All dimensions are at right angles. Expansion gap and dimension "A" shall be increased 1/4" for each 10° fall in temperature and decreased 1/4" for each 10° rise in temperature.

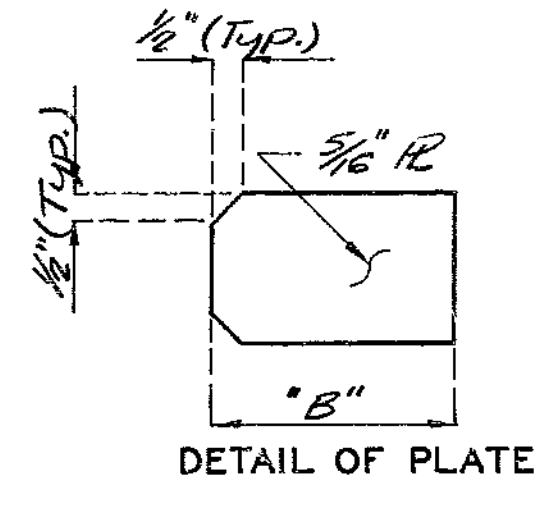

DETAIL OF PLATE

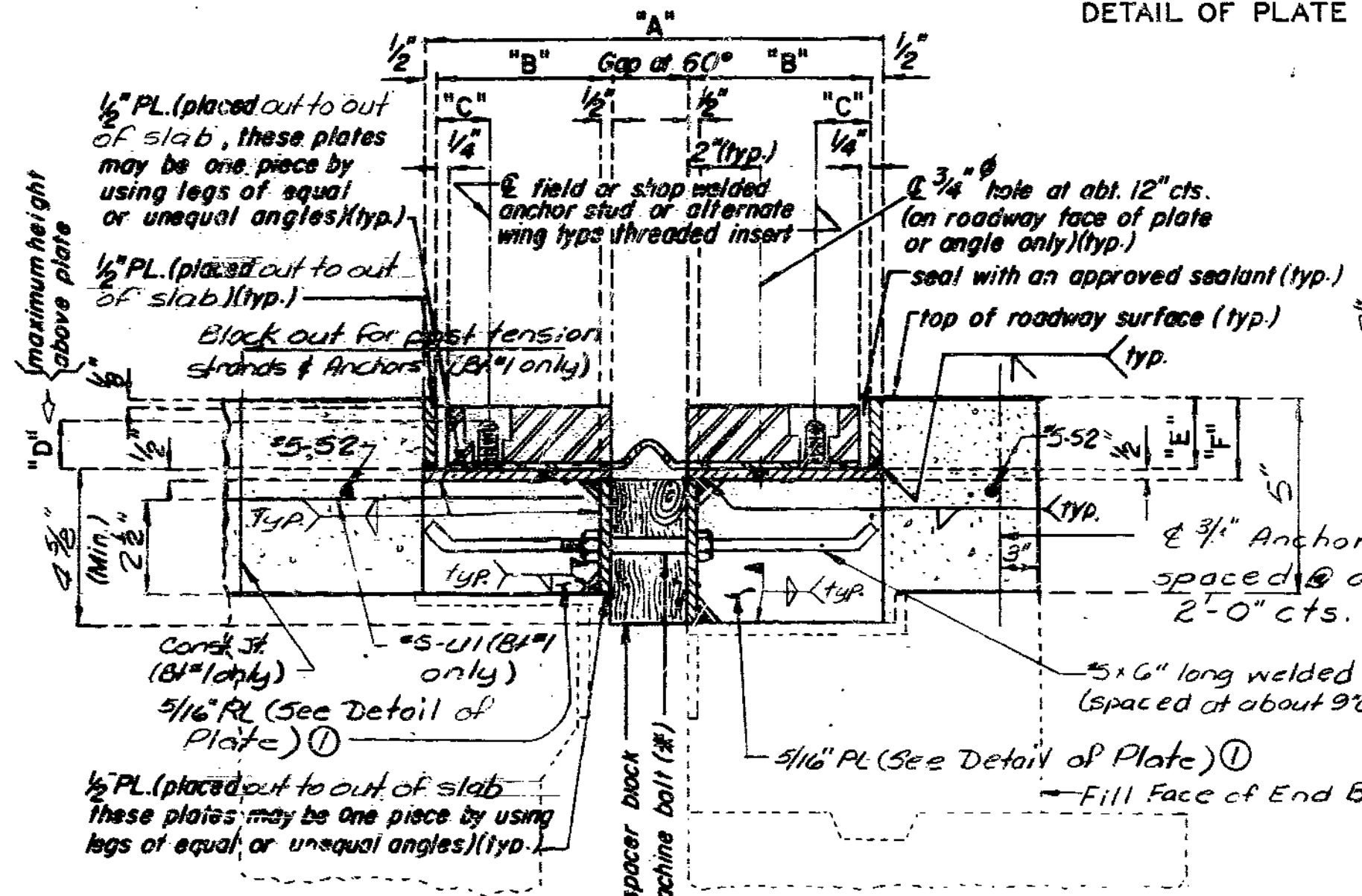

PART SECTION THRU ARMORED JOINT IN SLAB

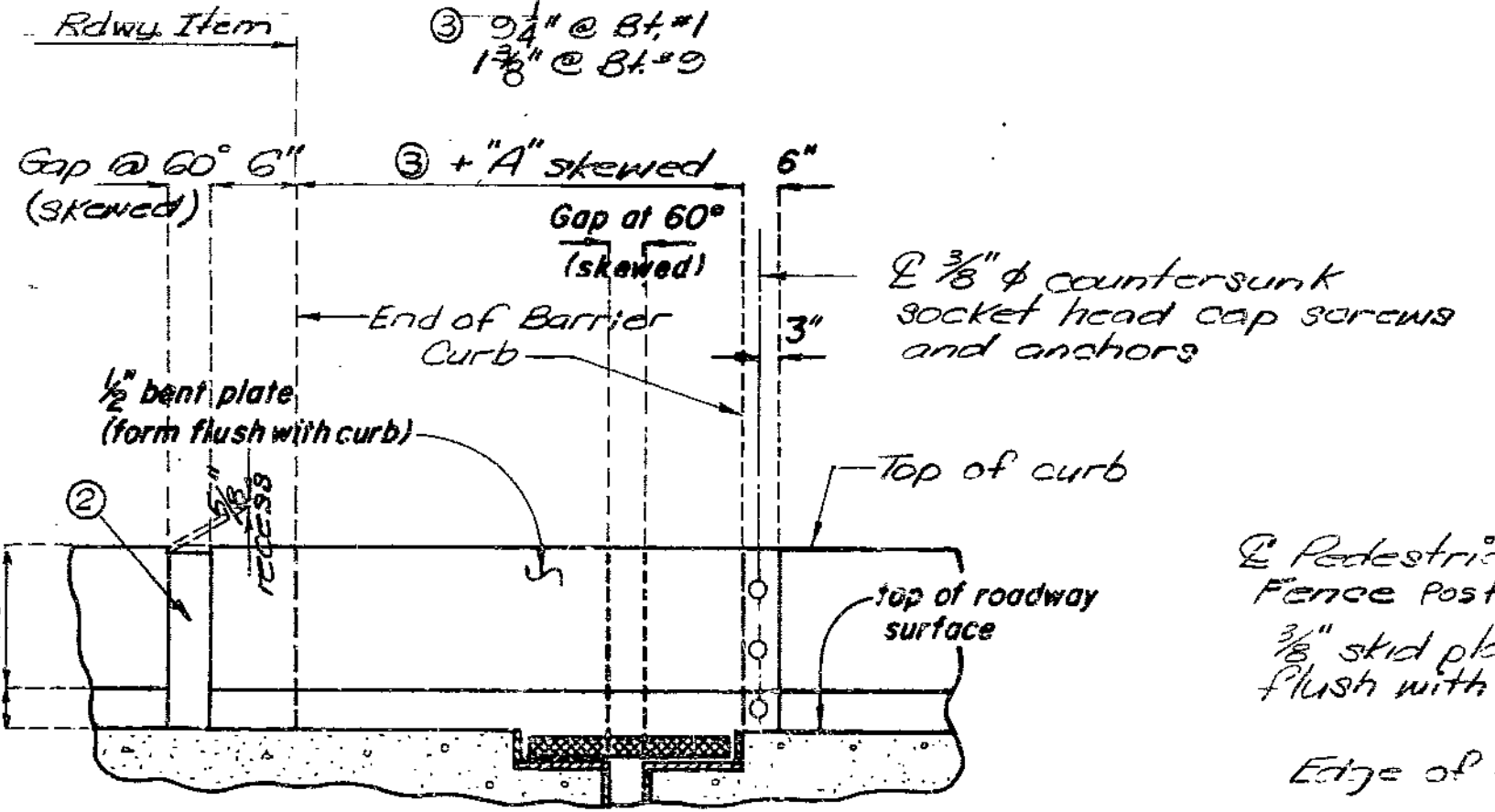

ELEVATION AT CURB

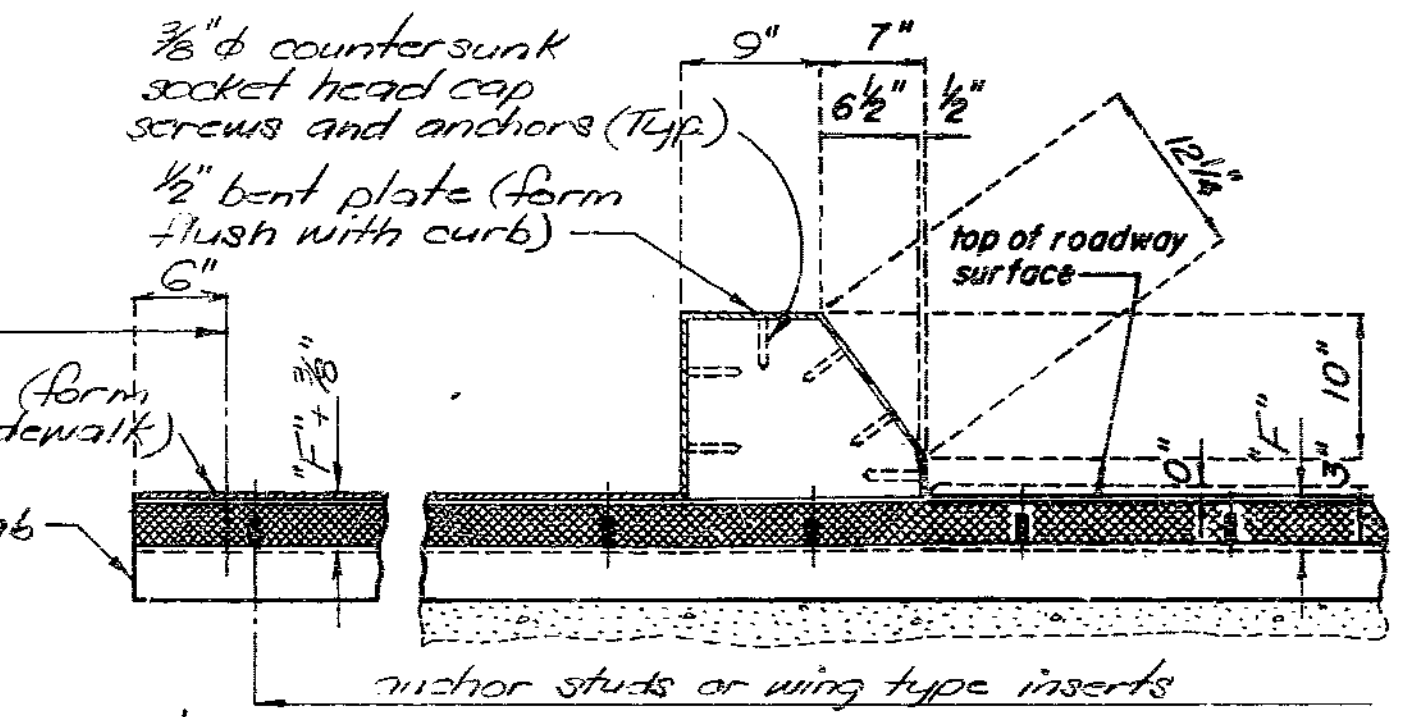

CURB TREATMENT

Note: Armor joint for exp. device to be lowered 3/8" to accommodate 3/8" sidewalk skid plate. Lowering to take place under barrier curb. Cost of furnishing and installing 1/2" curb plate shall be included in price bid for Safety Barrier Curb.

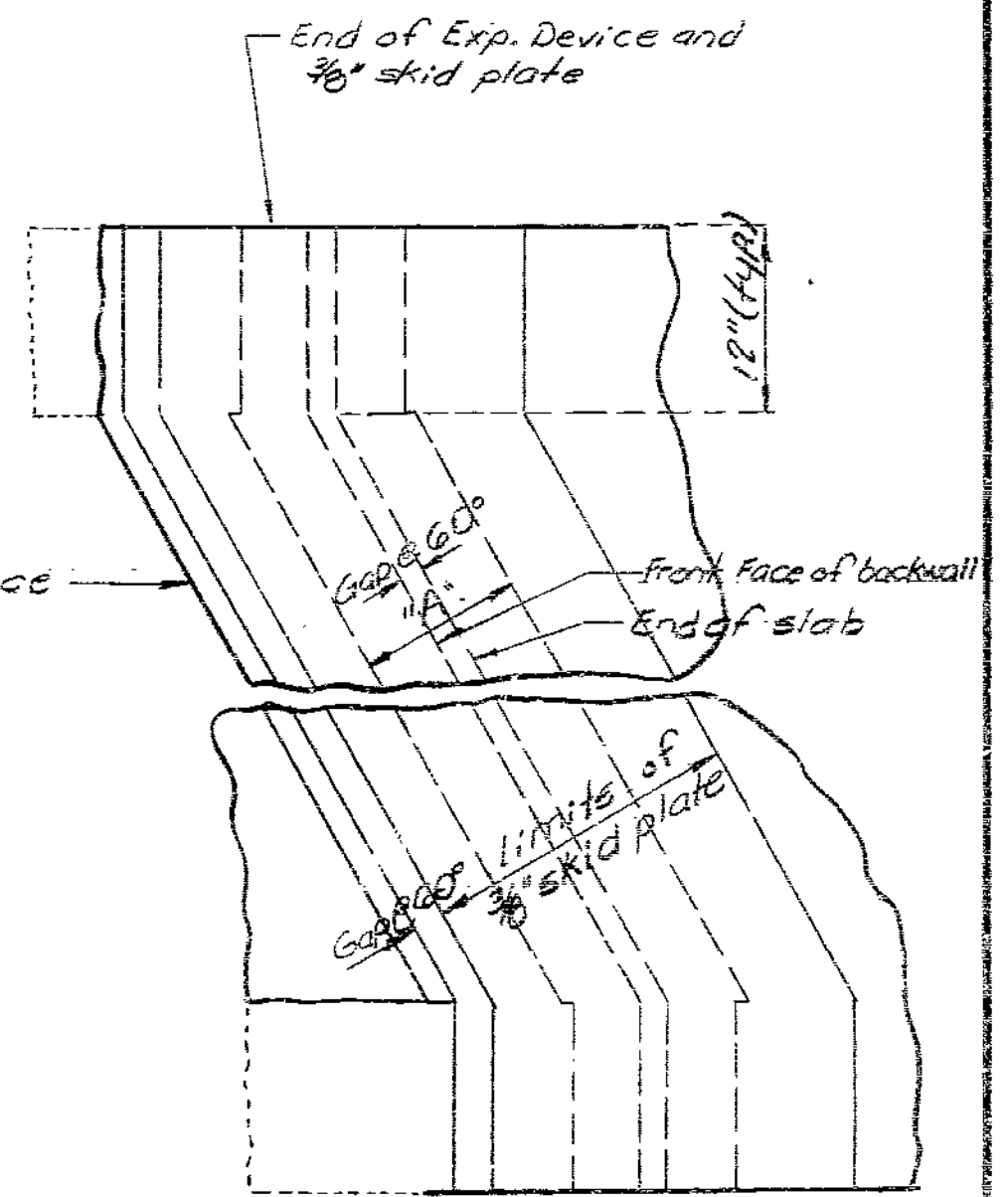

PART PLAN AT EXP DEVICE

(Bt. No. 1 shown - Bt. No. 9 similar)

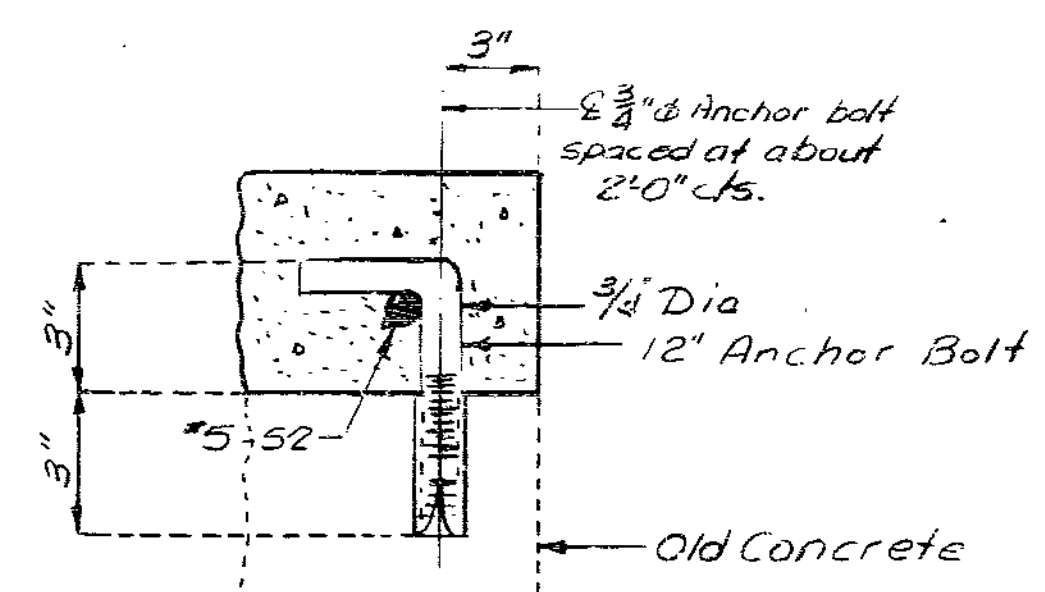

ANCHOR BOLT DETAIL

Note: Anchors shall be of the self-drilling expansion type, made of case hardened and drawn carburized steel, with self-cutting annular bracing grooves. Cost of furnishing and installing anchor bolt assemblies shall be included in price bid for concrete.

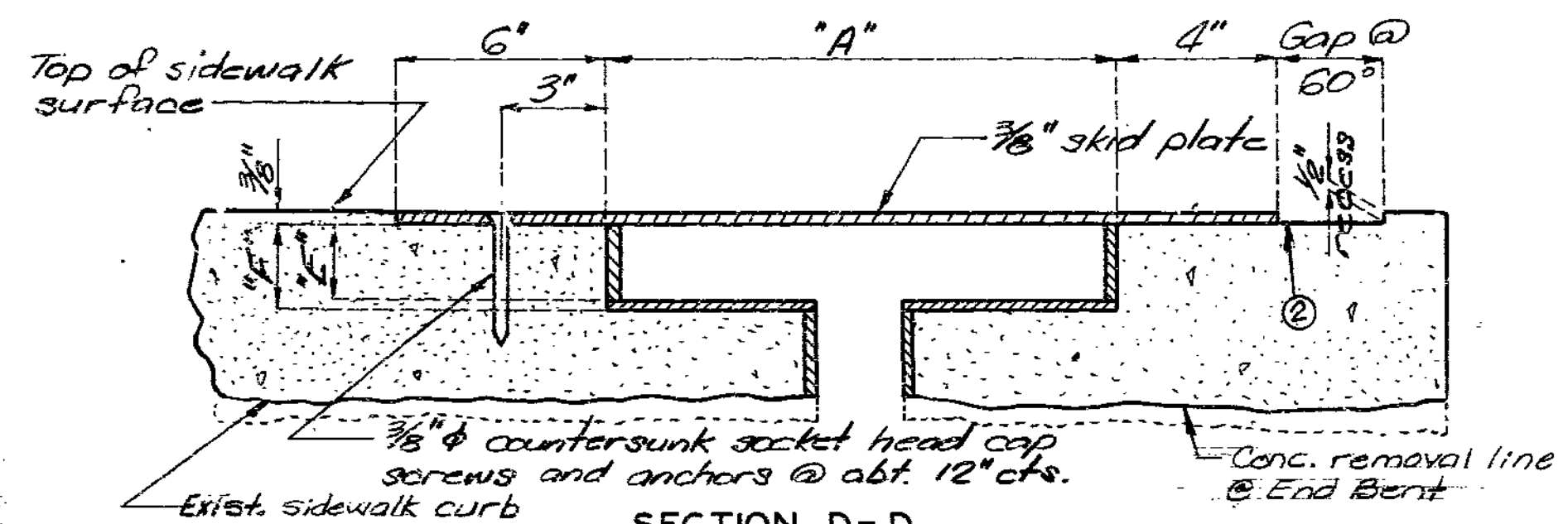

SECTION D-D (SIMILAR TO "PART SECTION THRU ARMORED JOINT IN SLAB" EXCEPT AS SHOWN)

② 2-layers 50# roofing felt between plate and recess. Cost of furnishing and installing 3/8" skid plate shall be included in price bid for Elastomeric Exp. Jt. Seal (2.5").

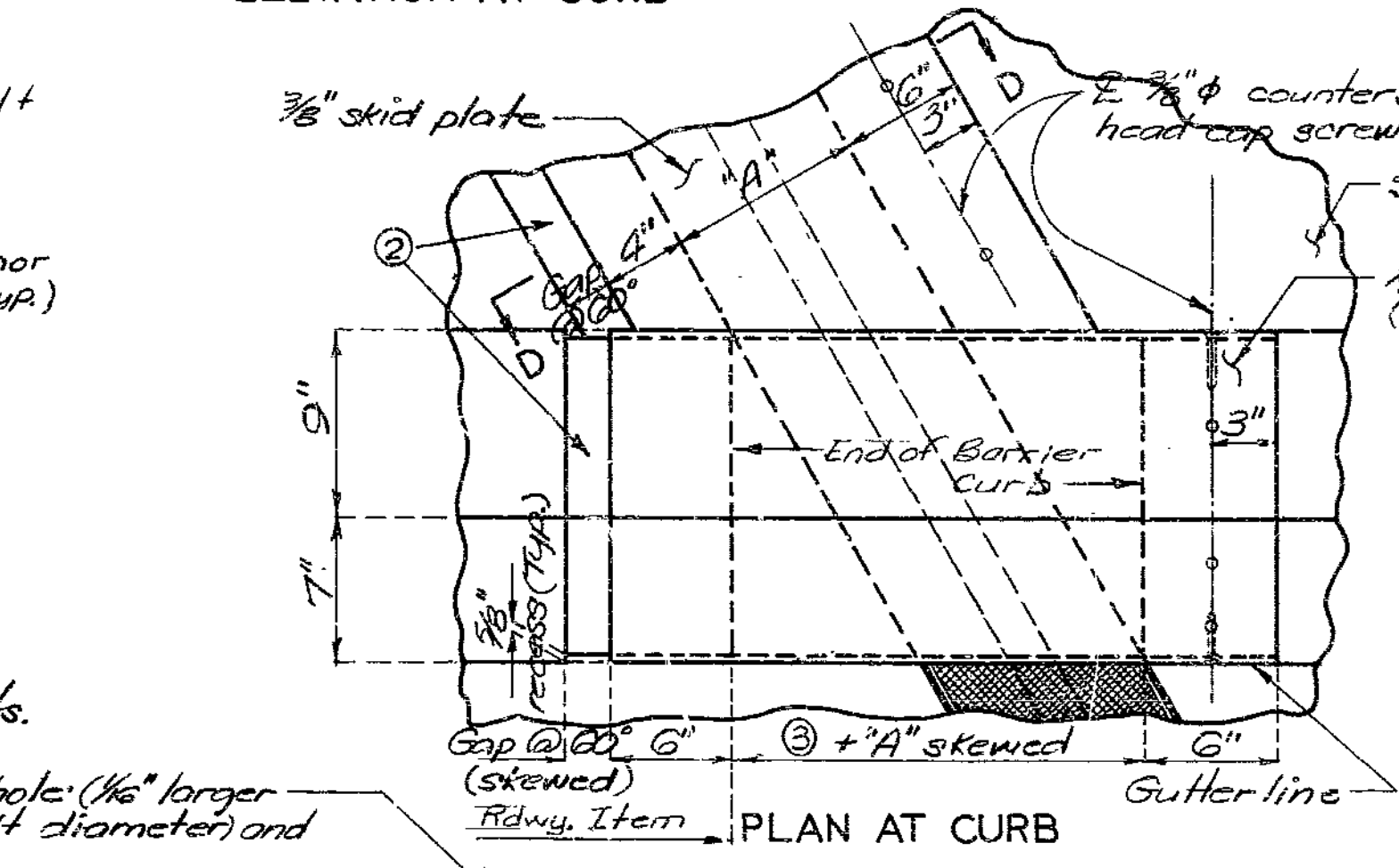

PLAN AT CURB

Bolt Diameter	Safe Load Tension (lbs.) (min.)	Approx. Ult. Cap. Tension (lbs.) (min.)	Dimensions		
			a	b	c
1/2"	800	8,000	1-5/8"	5"	218"
5/8"	1,300	9,200	1-5/8"	5"	218"
3/4"	1,800	13,200	2-1/4"	6"	262"
7/8"	2,000	16,200	2-1/2"	6-1/2"	306"
1"	2,000	16,200	2-1/2"	6-1/2"	306"

DETAILS OF ALTERNATE WING TYPE THREADED INSERT

(Machine bolts need only be used to secure the Wing Type Threaded Inserts to the steel plate until the concrete has attained 3,000 p.s.i.)

DETAILS OF ELASTOMERIC EXPANSION JOINT SEAL AT BENTS NO. 1 & 9,

Note: This drawing is not to scale. Follow dimensions.

Sheet No. 5 of 8

JACKSON

COUNTY

A-807R

358

SPS - END BT. REVISED FEB. 1976 AUG. 1983

DATE: June 1984
CHECKED: June 1984

FED. ROAD DIST. NO.	STATE	FED. AID PROJ. NO.	FISCAL YEAR	SHEET NO.	TOTAL SHEETS
5	MO.		19	27	

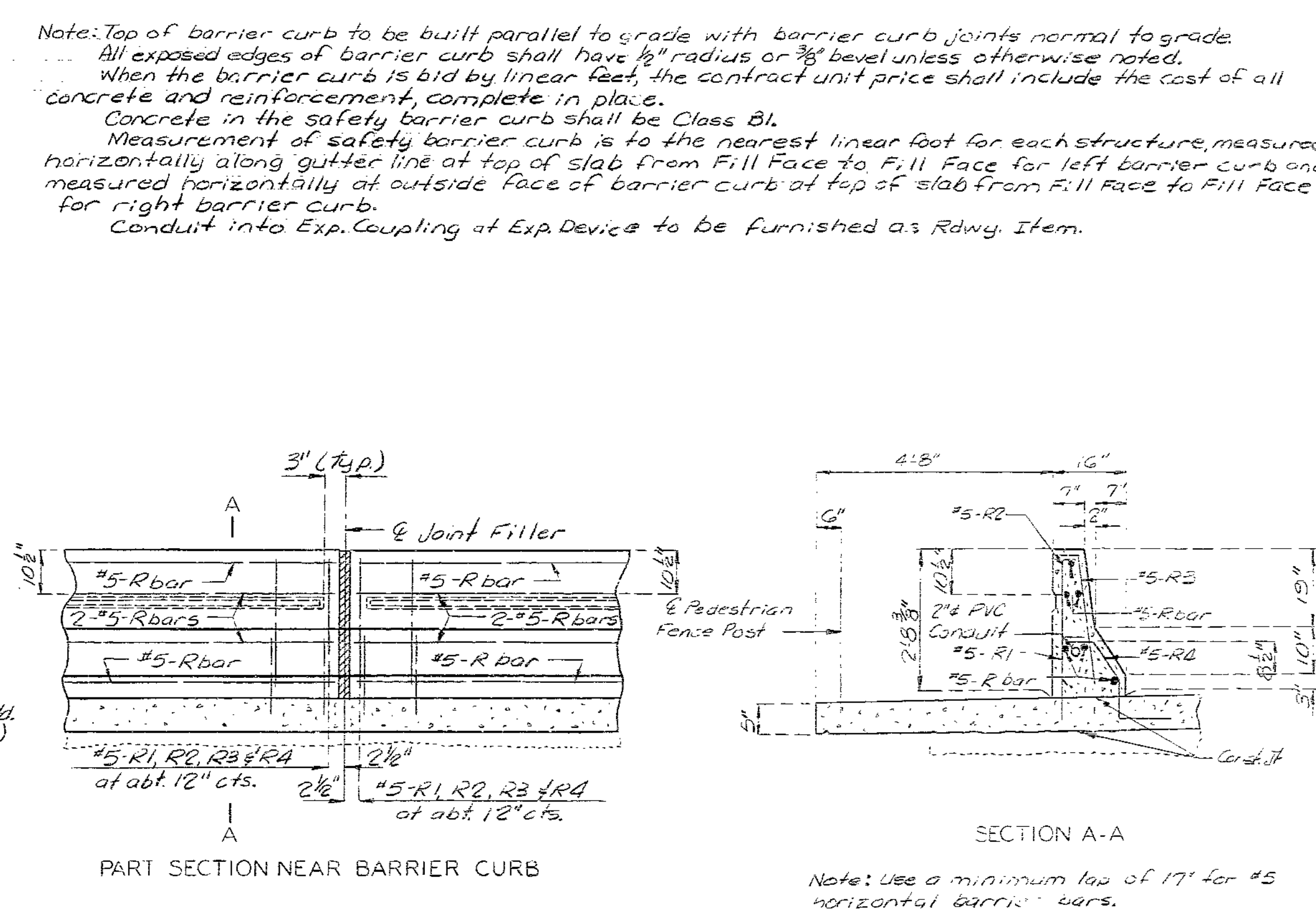
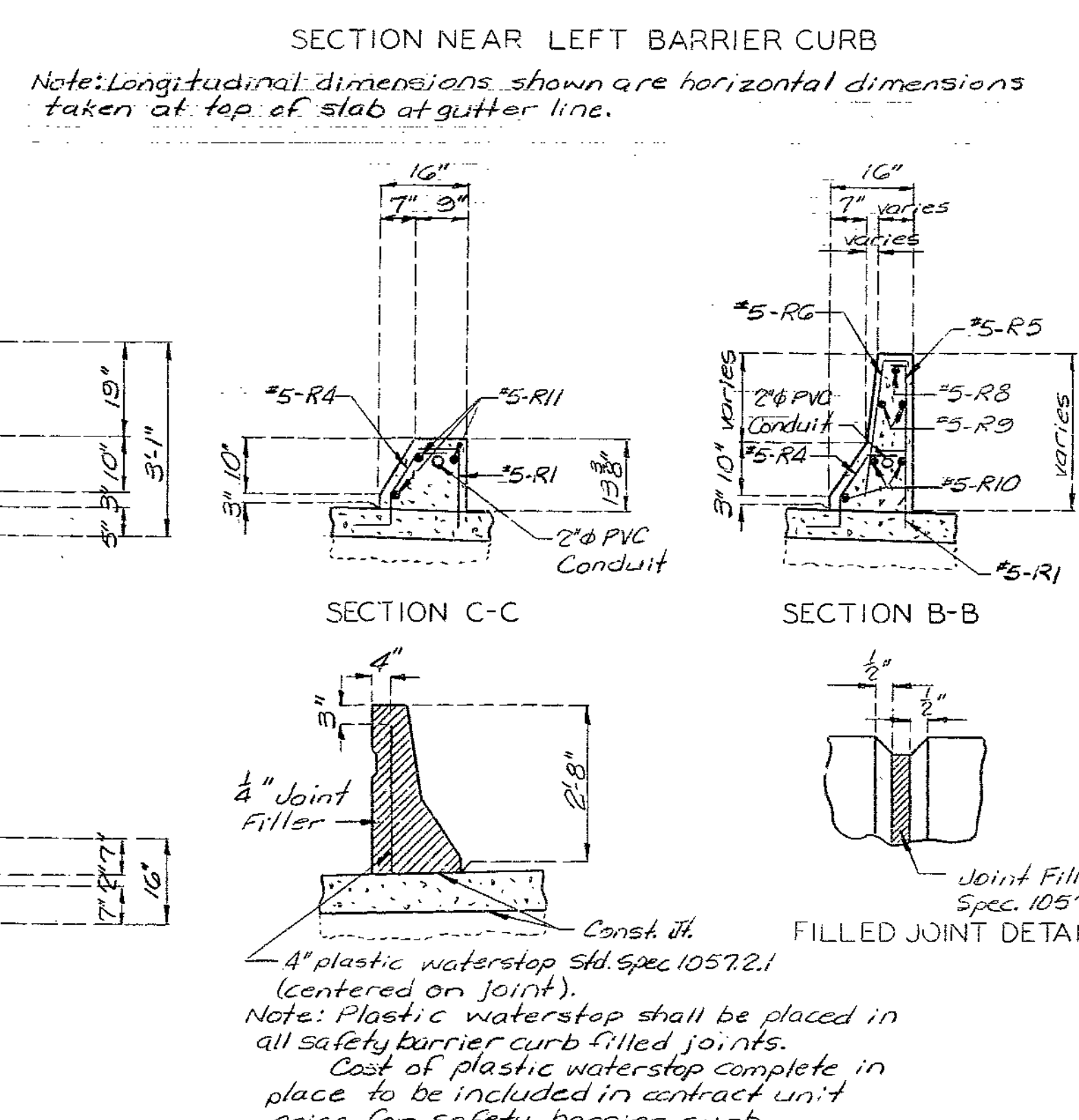
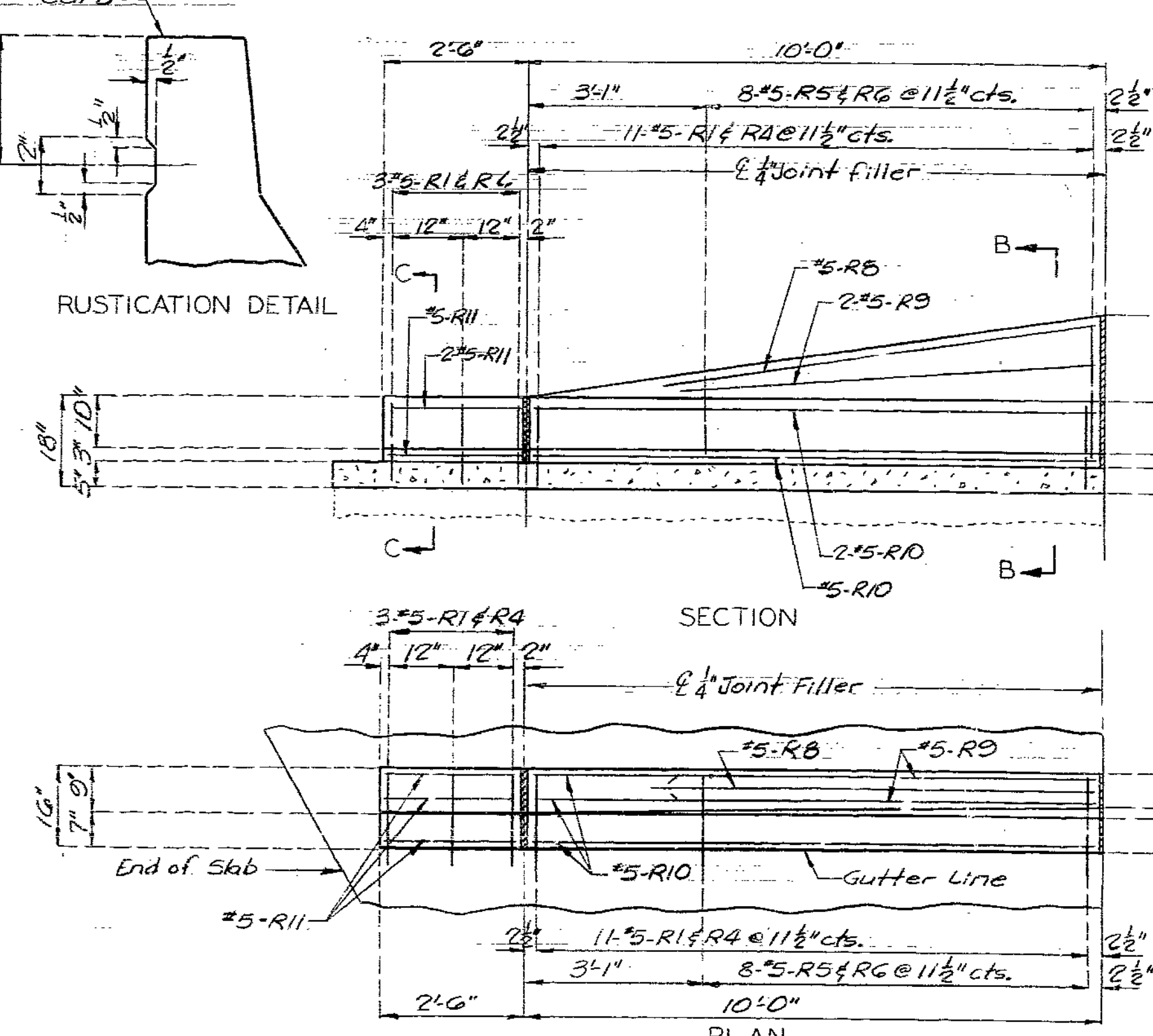
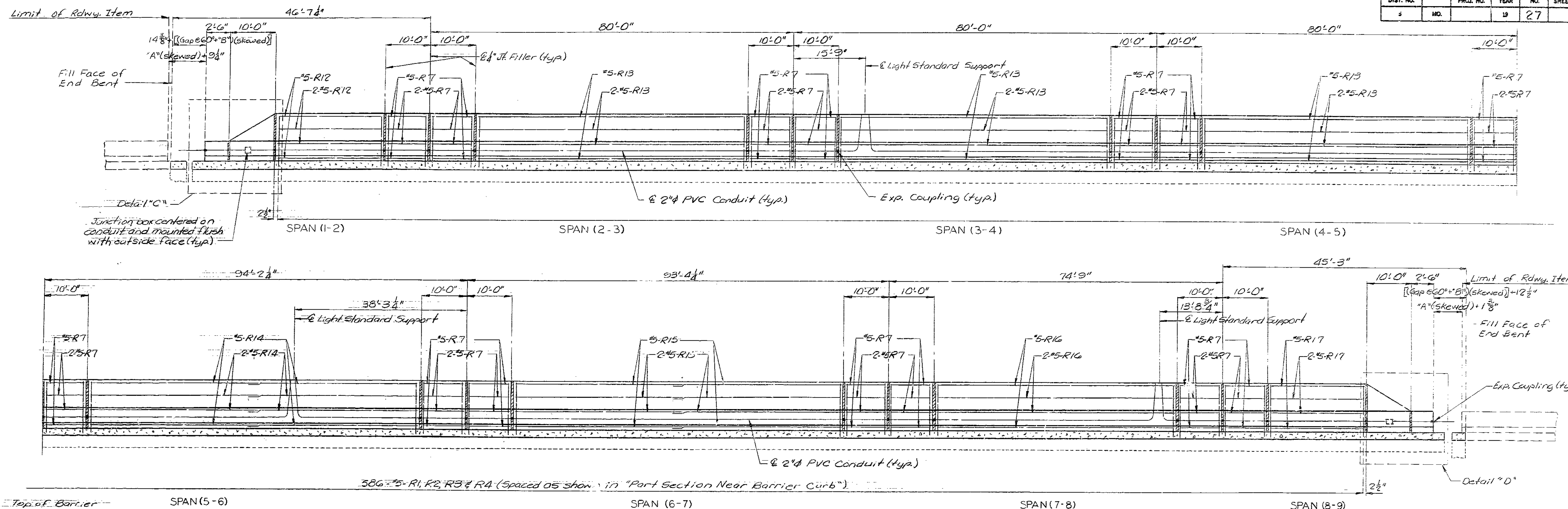

359
 DETAILED May 1984
 CHECKED June 1984

Note: This drawing is not to scale. Follow dimensions.

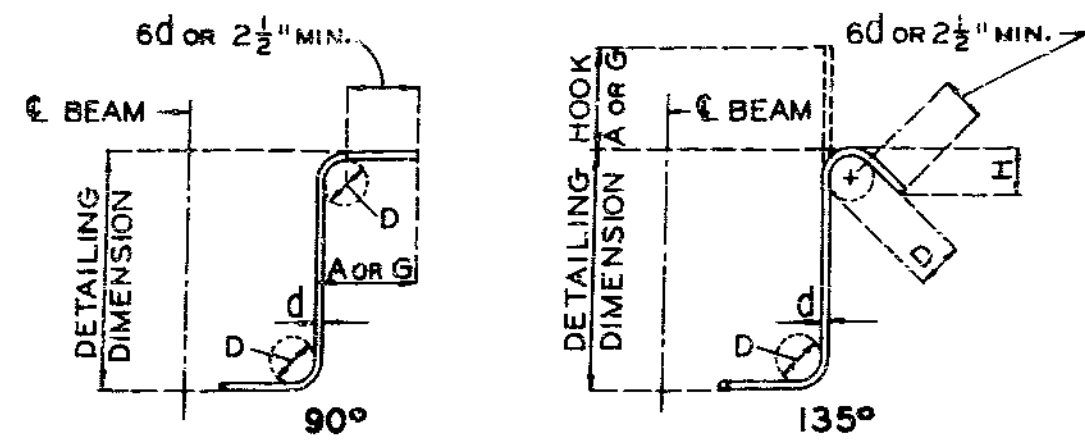

STIRRUP HOOK DIMENSIONS				
GRADES 40-50-60 KSI				
BAR SIZE	D (IN.)	90° HOOK		135° HOOK
		HOOK A OR G	HOOK A OR G	APPROX. H
#3	1-1/2"	4"	4"	2-1/2"
#4	2"	4-1/2"	4-1/2"	3"
#5	2-1/2"	6"	5-1/2"	3-3/4"
#6	4-1/2"	8"	7"	4-1/2"

NOTE: UNLESS OTHERWISE NOTED DIAMETER "D" IS THE SAME FOR ALL BENDS AND HOOKS ON A BAR.

BAR SIZE	180° HOOKS				90° HOOKS	
	GRADE 40		GRADE 60		ALL GRADES	
	A OR G	J	A OR G	J	A OR G	
#3	5"	2-3/4"	5"	3"	6"	
#4	6"	3-1/2"	6"	4"	8"	
#5	7"	4-1/2"	7"	5"	10"	
#6	8"	5-1/4"	8"	6"	12"	
#7	9"	6-1/4"	10"	7"	14"	
#8	10"	7"	11"	8"	16"	
#9	12"	8"	15"	11-1/4"	19"	
#10	13"	9"	17"	12-3/4"	22"	
#11	14"	10"	19"	14-1/4"	21-0"	
#14	21-2"	20-1/2"	21-2"	20-1/2"	21-7"	

SIZE OF 180° HOOKS (GRADE 40 KSI)
 D = 5d FOR #3 THRU #11
 D = 10d FOR #14 AND #18

SIZE OF 90° HOOKS (ALL GRADES) AND 180° HOOKS (GRADE 60 KSI)
 D = 6d FOR #3 THRU #8
 D = 8d FOR #9, #10 AND #11
 D = 10d FOR #14 AND #18

NOTES:

ALL STANDARD HOOKS AND BENDS OTHER THAN 180 DEG. TO BE BENT WITH SAME PROCEDURE AS FOR 90 DEG. STD. HOOKS.
 HOOKS AND BENDS SHALL BE IN ACCORDANCE WITH THE PROCEDURES AS SHOWN ON THIS SHEET.
 E - EPOXY COATED REINFORCEMENT.
 S - STIRRUP.
 X - BAR IS INCLUDED IN SUBSTRUCTURE QUANTITIES.
 Y - BAR DIMENSIONS VARY IN EQUAL INCREMENTS BETWEEN DIMENSIONS SHOWN ON THIS LINE AND THE FOLLOWING LINE.
 NO. EA. - NUMBER OF BARS OF EACH LENGTH.
 NOMINAL LENGTHS - ARE BASED ON OUT TO OUT DIMENSIONS SHOWN IN BENDING DIAGRAMS AND ARE LISTED FOR FABRICATORS USE. (NEAREST INCH)
 ACTUAL LENGTHS - ARE MEASURED ALONG CENTERLINE BAR TO THE NEAREST INCH.
 PAYWEIGHTS ARE BASED ON ACTUAL LENGTHS.

COMPLETE BILL OF REINFORCING STEEL

NO. REQD.	MARK NO.	LOCATION	EPOXY (E)	SHAPE NO.	STIRRUP (S)	SUBSTR. (X)	VARIES (V)	NO. EACH	DIMENSIONS								NOMINAL LENGTH	ACTUAL LENGTH	WEIGHT			
									B	C	D	E	F	H	K	FT. IN.				FT. IN.	FT. IN.	FT. IN.
SUPERSTRUCTURE																						
1	5H1	BKWL	E	15	S				15.000	5	0.000				7.500	13.000	6	3	6	3	7	
459	5S1	SLAB	E	20					2	3.000							2	3	2	3	1077	
2	5S2	BKWL & SLAB	E	20					59	9.000							59	9	59	9	125	
2	5S3	BKWL & SLAB	E	20					51	11.000							51	11	51	11	108	
34	5U1	SLAB	E	10	S					2	5.000	9.000					5	7	5	5	192	
1200	5R1	BARRIER CURB	E	19	S				16.000		6.000						22	21			2190	
1144	5R2	BARRIER CURB	E	19	S				2	5.000	3.500						2	9	2	7	3082	
1144	5R3	BARRIER CURB	E	15	S				2	5.125	3.500				2	5.000	3.000	2	9	2	8	3182
1200	5R4	BARRIER CURB	E	27	S					6.000	11.125	5.000	12.000		9.125	6.375	2	10	2	8	3338	
32	5R5	BARRIER CURB	E	19	S		V	4	2	4.625	3.500						2	8	2	7	71	
		INCR = 1.625 IN								15.875	4.875						21	20			71	
32	5R6	BARRIER CURB	E	15	S		V	4	2	4.750	3.500			2	4.625	3.000	2	8	2	7	71	
		INCR = 1.625 IN								16.000	4.875			15.875	1.625		21	20			71	
170	5R7	BARRIER CURB	E	20					9	9.000							9	9	9	9	1729	
4	5R8	BARRIER CURB	E	20					8	0.000							8	0	8	0	33	
8	5R9	BARRIER CURB	E	20					7	6.000							7	6	7	6	63	
12	5R10	BARRIER CURB	E	20					9	9.000							9	9	9	9	122	
12	5R11	BARRIER CURB	E	20					2	3.000							2	3	2	3	26	
6	5R12	BARRIER CURB	E	20					21	11.000							21	11			137	
36	5R13	BARRIER CURB	E	20					59	9.000							59	9	59	9	2253	
12	5R14	BARRIER CURB	E	20					37	8.000							37	8	37	8	471	
12	5R15	BARRIER CURB	E	20					37	3.000							37	3	37	3	466	
6	5R16	BARRIER CURB	E	20					54	6.000							54	6	54	6	341	
6	5R17	BARRIER CURB	E	20					20	10.000							20	10	20	10	130	
6	5R18	BARRIER CURB	E	20					21	2.000							21	2	21	2	132	
12	5R19	BARRIER CURB	E	20					31	6.000							31	6	31	6	394	
12	5R20	BARRIER CURB	E	20					31	11.000							31	11	31	11	399	
6	5R21	BARRIER CURB	E	20					51	0.000							51	0	51	0	319	
6	5R22	BARRIER CURB	E	20					20	8.000							20	8	20	8	128	
18	5U70	LIGHT SUPPORT	E	10					6.000	2	4.750	12.000					6	4	5	11	111	
12	5U71	LIGHT SUPPORT	E	10					6.000	2	4.750	6.000					5	10	5	5	68	
30	5U72	LIGHT SUPPORT	E	15	S				22.625	22.750	22.625	16.000	16.000	16.000	16.000		5	8	5	7	175	
30	5U74	LIGHT SUPPORT	E	31	S				16.000	22.750	16.000						5	6	5	3	164	
48	5V70	LIGHT SUPPORT	E	20					3	0.000							3	0	3	0	150	
END OF BAR LIST																						

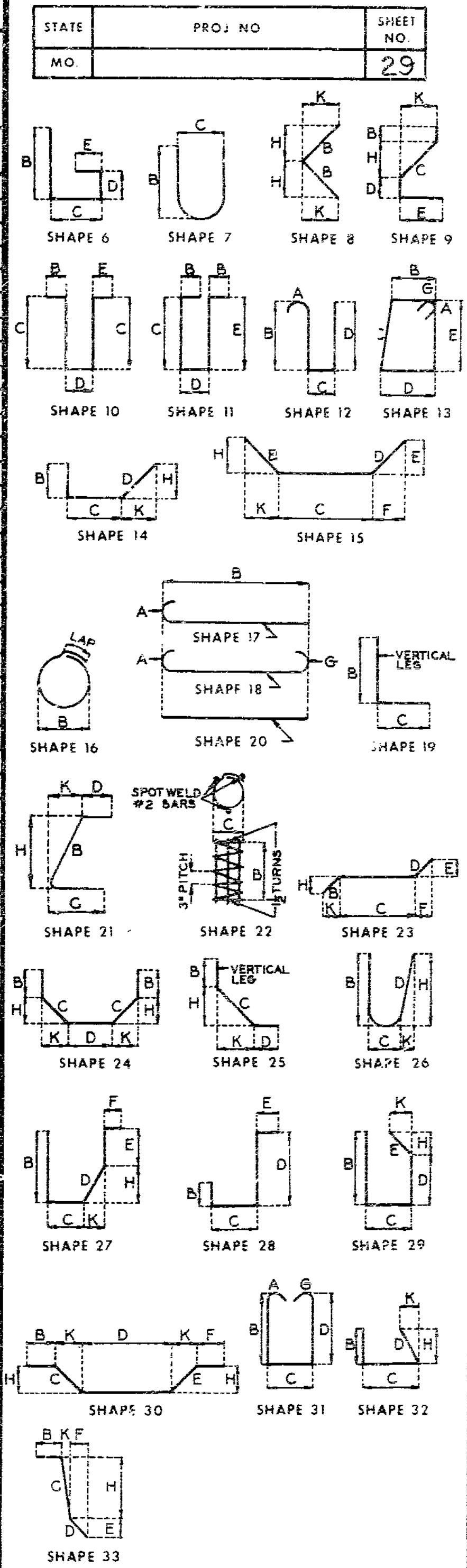

BENDING DIAGRAMS

① 2 additional #5-R7 bars are included in bar bill for testing.

361

STD. 90.8.5 REVISED MAY 1974
 MAY 1974
 REVISED MAY 1984

DETAILED June 1984
 CHECKED June 1984

Note: This drawing is not to scale. Follow dimensions.

Sheet No. 8 of 8

MISSOURI HIGHWAY AND TRANSPORTATION COMMISSION

FED. ROAD DIST. NO.	STATE	FED. AID PROJ. NO.	FISCAL YEAR	SHEET NO.	TOTAL SHEETS
5	MO.		19	22	
SEC./SUR. 5			TWP. 49N RGE. 33 W		

ESTIMATED QUANTITIES		
ITEM		TOTAL
Class B2 Concrete	Cu. Yds.	465.94
Safety Barrier Curb	Lin. Ft.	1161
Elastomeric Expansion Joint Seal (2.5 in.)	Lin. Ft.	112
Conduit System on Structure	Lump Sum	1
Post Tension System	Lump Sum	1
Special Work	Lump Sum	1
Shear Keys	Each	153
(72 in.) Pedestrian Fence (Structures)	Lin. Ft.	1200
Cleaning and Painting Bearings	Each	14
502.04 Repairing Concrete Deck (Half-Soling)	Sq. Ft.	926
502.02 Grout Sidewalk Area	Sq. Ft.	4338
502.03 Overhang Repair	Lin. Ft.	60
502.05 Tendon Anchor Chucks	Each	424
502.06 Repair of Tendons	Ft.	19066.27

Note: Cost of furnishing and installing #5, #5-53, #5-55, #5-57 and #4-4-4 welded wire fabric (epoxy coated) shall be included in price bid for Class B2 Concrete.

GENERAL NOTES

Design Specifications: A.A.S.H.T.O. & Interims thru 1982
 Design Loading: HS20-44 Modified 24,000* Tandem axle.
 Design Unit Stresses:
 Class B1 Concrete (safety barrier curb) $f_c = 16,000$ psi
 Class B2 Concrete (superstructure except safety barrier curb) $f_c = 20,000$ psi.
 Reinforcing Steel (Grade 60) $f_s = 24,000$ psi.

Joint Filler:

All joint filler shall meet the requirement of Std. Spec. 1057.2.4 except as noted.

Reinforcing Steel:

Minimum clearance to reinforcing steel shall be $1\frac{1}{2}$ " unless otherwise shown.
 Adequate reinforcing other than the specified welded wire fabric may be used with the approval of the engineer.
 Bars bonded in old concrete not removed shall be cleanly stripped and embedded into new concrete where possible (does not apply to slab steel). If length is available old bars shall extend into new concrete of least 40 diameters for smooth bars and 30 diameters for deformed bars.
 Contractor shall verify all dimensions in field before ordering new material.

Post Tensioning:

Post tensioning strands shall be $\frac{1}{2}$ " diameter epoxy coated seven-wire low relaxation strands with an initial post tension force of 30.98 Kips, conforming to AASHTO M203, Grade 270.

The method and sequence of stressing the strands shall be shown on the shop drawings. Suitable strand anchorage devices shall be cast in overlay and shall be shown on shop drawings and approved by the engineer.

Details shown on these plans are not indicative of any particular type of Post Tension Anchorage System.

PVC duct friction factors were computed for $m = 0.08$, $k = 0.0014$. Anchor set for all strands was computed at $\frac{1}{4}$ " and for transverse bars was computed at 0".
 Threaded bars shall be $\frac{3}{8}$ " nominal diameter epoxy coated with an initial post tension force of 31.50 Kips, and conforming to AASHTO M275, Type I or Type II.

In no case shall the working stress in the concrete due to post tensioning after anchorage and all losses provide less compressive stress than 140 psi.

Construction Clearance:

Falsework over exist. Lane A and Lane B shall be constructed with a minimum vertical clearance of 14'6" from crown of exist lanes and a minimum lateral clearance of 4'0" centered on exist lanes.
 Falsework over exist. Lane K and Lane J shall be constructed with a minimum vertical clearance of 14'6" from crown of exist lanes and a minimum lateral clearance of 24'0" centered on exist lanes.

Conduit System:

Shift reinforcement steel in field where necessary to clear conduit and junction boxes.
 The junction boxes shall be PVC molded flush mounted, size 8" x 8" x 4". They shall be equal to "Corlon" Electrical Construction Products or "Triangle" Conduit and Cable Co. Inc. The conduit terminations shall be permanent or separable. The terminations and cover shall be watertight construction.
 Conduit shall be schedule 40 Heavy Wall PVC (Polyvinyl Chloride) plastic or HDPE (High Density Polyethylene) with 3" minimum cover in concrete.
 Expansion couplings shall provide a minimum movement in either direction of $2\frac{1}{2}$ " at open joints at bents No. 1 & 9 and a minimum movement in either direction of $\frac{1}{2}$ " at filled joints.
 All wiring to be furnished and installed by others.
 Top of light standard supports to be made horizontal, anchor bolts to be placed vertically.

The contractor shall pour and satisfactorily finish the slab pours for the sequence as shown on the "Plan of Slab" - sh. no. 2.

The test system for epoxy coated reinforcing as specified in Sec. 710.3.4 of the Standard Specification will not be required on this bridge.

Top of backwall and exp. device for end Bts. 1 & 9 to conform to crown of roadway slab. Conc. above top of exist. backwall shall not be poured until the superstructure slab has been poured in the adjacent span.

Outline of old work is indicated by light dashed lines, heavy lines indicate new work.

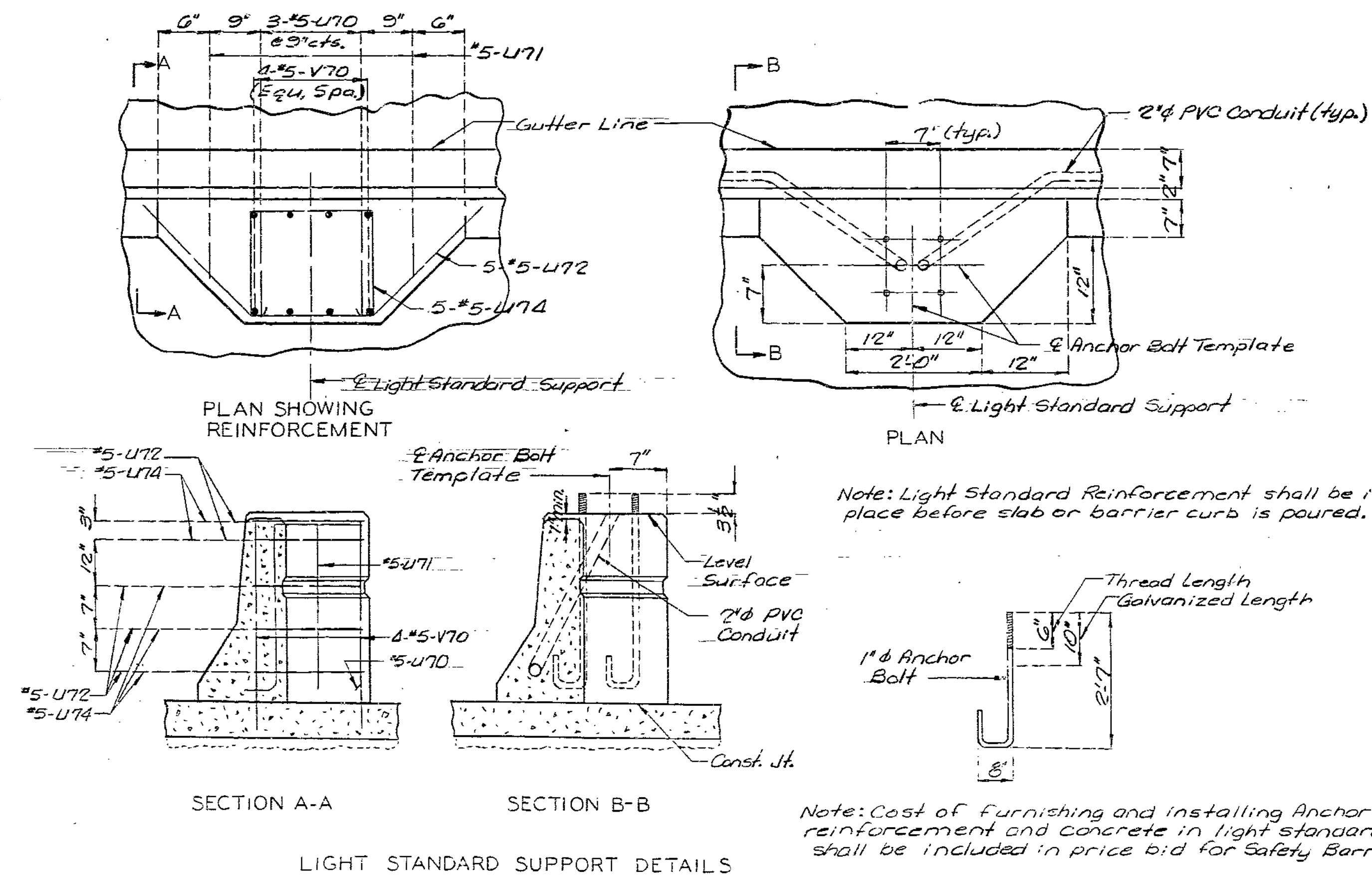

Note: Light Standard Reinforcement shall be in place before slab or barrier curb is poured.

Note: Cost of furnishing and installing Anchor Bolts, reinforcement and concrete in light standard support, shall be included in price bid for Safety Barrier Curb.

B.M.

BRIDGE: CHARLOTTE STREET UNDERPASS

STATE ROAD: I-35 & I-70 INTERCHANGE

ABOUT 14 TH & CHARLOTTE

PROJECT NO. IR-35-1(204) STA. 47+59.11 E LANE 2

JOB NO. 4-I035-139B

RTE. I-35

JACKSON

COUNTY

STD.
STD. 706.35
A-807R

DESIGNED April 1984
 DETAILED May 1984
 CHECKED June 1984

Note: This drawing is not to scale. Follow dimensions.

Sheet No. 1A of 8.

DATE June 29, 1984

362